

Model

Designation	NLE11CNL	115-127V/60Hz 1~	Sales code:	105H5986
-------------	-----------------	------------------	-------------	-----------------

Compressor design

Oil type	Polyolester	Refrigerant(s)	R290
Oil viscosity	32cST	Displacement	11,15cm ³ / 0,68cu.in
Oil quantity	298cm ³ / 10,1fl.oz	Compressors on pallet	80
Refr. charge - tech. limit	400g / 14,1oz		
Free gas volume comp.	2360cm ³ / 79,8fl.oz		
Weight	12,13kg / 26,7lbs		
Motor protection	1# internal		
Winding resistance main	1,1Ω (at 25°C)		
Winding resistance aux	3,61Ω (at 25°C)		
Max. winding temp.	125°C / 257°F		
Max. discharge temp.	130°C / 266°F		



General - Configurations with NLE11CNL

	Conf. 1
Motorconfiguration	RSCR
Power supply (nominal)	115V/60Hz
Number of phases	1
Voltage range	95-135V
Approvals	UL, CCC
Starting torque	LST
Note	Electrical equipment is included and pre-assembled to compressor.

Applications with NLE11CNL

	Conf. 1
Refrigerant	R290
Application	LBP
System cooling	fan 3m/s
Hot gas defrost	OK
Long interval pull down	-/-

Electrical data - Configurations with NLE11CNL

	Conf. 1
Starting device type	PTC
Run capacitor	23,5μF
Start capacitor	-/-
LRA (locked rotor amps / 4s)	29,91A
RLA (rated load amps / 1s)	5,74A
Cut in current	39,82A

Model

Designation

NLE11CNL

115-127V/60Hz 1~

Sales code:

105H5986

Compressor dimensions

Housing	A Height	203mm / 7,99in
	B Height	197mm / 7,76in
	C Length shell	205mm / 8,07in
	D Length w. cover	254mm / 10in
	E Width	166mm / 6,54in

Connectors		Suction	Discharge	Process
		X	Y	Z
Diameter	[mm]	øi 8,11-8,29	øi 6,41-6,59	øi 6,41-6,59
	(i:inside, o:outside) [in]	øi 0,32-0,33	øi 0,25-0,26	øi 0,25-0,26
Material		copper	copper	copper
Horizontal angle	±2°	0°	0°	0°
Vertical angle	±2°	15°	21°	155°
Position l/h/w	[mm]	132/69/57	94/102/81	-109/94/72
	[in]	5,2/2,7/2,2	3,7/4/3,2	-4,3/3,7/2,8
Straight tube l.	[mm]	12	12	12
	[in]	0,5	0,5	0,5

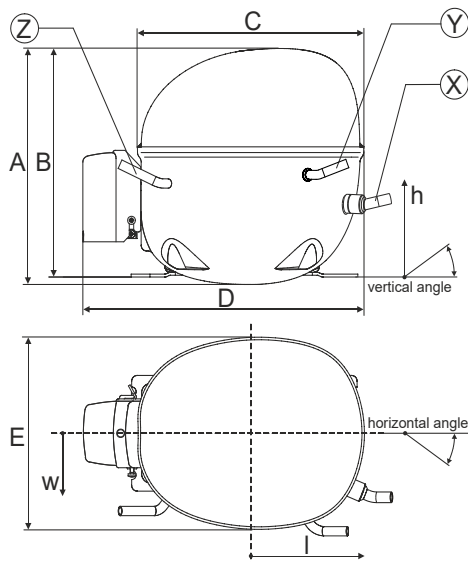

Compressor fixation

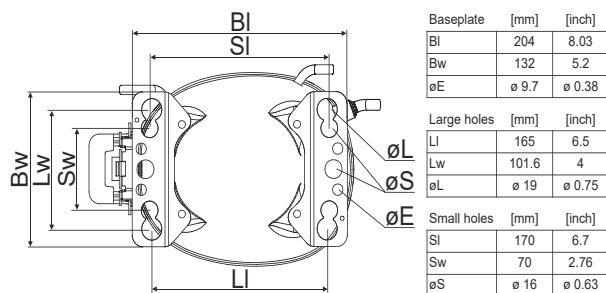

Bolt joint

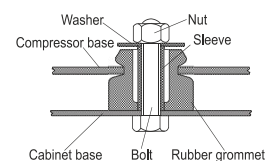

Snap-on

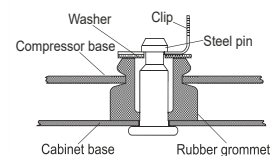

Mounting accessories

	one comp.	multi pack
Bolt joint M6 ø16mm	118-1917	118-1918
Bolt joint ø1/4" ø16mm	118-1946	
Bolt joint ø1/4" ø19mm	118-1949	
Snap-on ø7,3 ø16mm	118-1947	118-1919

Application notes

LRA value on compressor label and datasheet may differ due to different test conditions for UL approval.

Provision for PE Grounding is located at the PE Stamp on the compressor

Model

Designation	NLE11CNL	115V/60Hz	Conf. 1	Sales code:	105H5986
-------------	-----------------	------------------	----------------	-------------	-----------------

Configuration

Motorconfiguration	RSCR	
Power supply (nominal)	115V/60Hz 1~	
Refrigerant	R290	
Application	LBP	
Voltage range	95-135V	
Starting torque	LST	
Approvals	UL	SA3693
	CCC	

Electrical accessories / wiring diagram

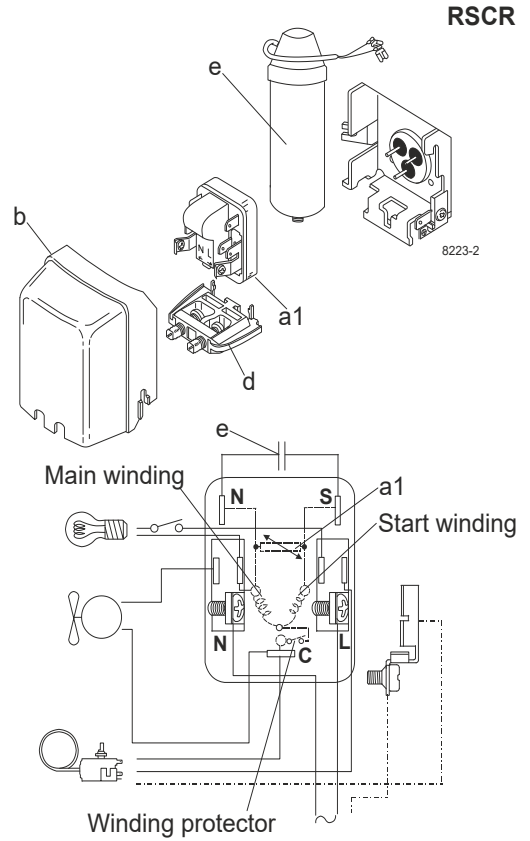

Ambient/ machine room temperatures minimum /maximum

Ambient temperature range: 10 - 43°C / 50 - 110°F

Machine room temperature range: 10 - 48°C / 50 - 119°F

Compressor cooling: fan 3m/s

Operation pressure range

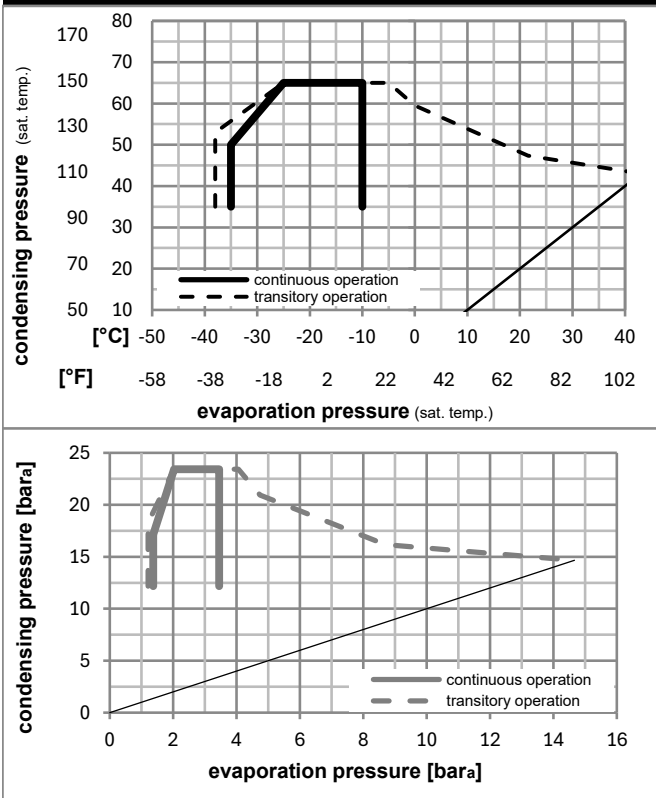

Components (already pre-assembled)

a1	e-PTC starter	103N0058
e	run capacitor (23,5μF, 6.3mm)	117-7114
b	plastic cover	103N2011
d	cord relief	103N1010
	bracket for run capacitor	117-0300
	screw M4x8mm	117-0301

Model

Designation	NLE11CNL	115V/60Hz	Conf. 1	Sales code:	105H5986
-------------	-----------------	------------------	----------------	-------------	-----------------

Optimization + standard conditions

R290, 115V/60Hz, RSCR, fan 3m/s, UL, CCC

	Evaporating pressure (saturation temperature)				Cooling capacity			COP	EER	P1	Power consumption		ASHRAE LBP	
	pe	pc	RGT	Tliq	[W]	[Btu/h]	[kcal/h]				I	m		
	[°C]	[°F]	[°C]	[°F]	[W]	[Btu/h]	[kcal/h]	[W/W]	[Btu/Wh]	[kcal/Wh]	[W]	[A]	[kg/h]	
	-23	54	32	32	685,2	2340	589,7	1,77	6,04	1,52	387,2	4,49	6,94	ASHRAE LBP
	-10	130	90	90										
	-25	55	32	55	513,2	1753	441,6	1,38	4,70	1,19	372,6	4,38	6,39	cecomaf LBP
	-13	131	90	131										
	-35	40	20	40	383,9	1311	330,4	1,38	4,70	1,19	278,8	3,78	4,39	EN12900 LBP
	-31	104	68	104										
	-23	49	4,4	49	553,2	1889	476,0	1,46	5,00	1,26	377,8	4,42	7,66	ARI540 LBP
	-10	120	40	120										
	-23	41	32	32	727,3	2484	625,9	2,03	6,92	1,74	359,0	4,31	7,36	AHAM LBP
	-10	105	90	90										
	-35	45	32	45	368,5	1258	317,1	1,31	4,49	1,13	280,2	3,79	4,13	opt
	-31	113	90	113										

Performance tables

R290, 115V/60Hz, RSCR, fan 3m/s, UL, CCC

	pe		Cooling capacity			COP	EER		P1	I	m
	[°C]	[°F]	[W]	[Btu/h]	[kcal/h]		[Btu/Wh]	[kcal/Wh]			
[°C / °F]	-35	-31	368,5	1258	317,1	1,31	4,49	1,13	280,2	3,79	4,13
cond. pressure	-29	-20	494,3	1688	425,4	1,51	5,14	1,30	328,4	4,07	5,56
pc= 45/113	-26	-15	563,8	1926	485,3	1,61	5,51	1,39	349,2	4,22	6,35
return gas temp.	-23	-10	640,7	2188	551,4	1,73	5,92	1,49	369,7	4,37	7,23
RGT= 32/90	-21	-5	724,4	2474	623,5	1,86	6,34	1,60	390,1	4,54	8,20
liquid temp	-15	5	911,6	3113	784,6	2,11	7,22	1,82	431,4	4,87	10,37
Tliq= 45/113	-10	14	1100,8	3759	947,3	2,34	7,99	2,01	470,3	5,17	12,59
[°C / °F]	-35	-31	316,9	1082	272,7	1,15	3,93	0,99	275,6	3,81	3,92
cond. pressure	-29	-20	425,7	1454	366,4	1,27	4,33	1,09	336,1	4,13	5,28
pc= 55/131	-26	-15	486,8	1663	419,0	1,34	4,59	1,16	362,3	4,31	6,06
return gas temp	-23	-10	554,7	1894	477,4	1,43	4,88	1,23	387,9	4,49	6,92
RGT= 32/90	-21	-5	629,1	2148	541,4	1,52	5,20	1,31	413,2	4,69	7,86
liquid temp	-15	5	796,0	2719	685,1	1,72	5,86	1,48	463,8	5,11	10,01
Tliq= 55/131	-10	14	965,4	3297	830,8	1,89	6,46	1,63	510,4	5,50	12,21