

NLE11MF.2 Energy-optimized MBP Compressor R134a 220-240V 50Hz

General

Code number	105G6197
Approvals	EN 60335-2-34 w. Annex AA, CCC
Compressors on pallet	80

Application

Application	LBP/MBP		
Frequency	Hz	50	60
Evaporating temperature	°C	-25 to 10	-
Voltage range	V	198 to 242/254	-
Max. condensing temperature continuous (short)	°C	65 (70)	-
Max. winding temperature continuous (short)	°C	125 (135)	-

Cooling requirements

Frequency	Hz	50			60		
Application		LBP	MBP	HBP	LBP	MBP	HBP
32°C		F ₂	F ₂	-	-	-	-
38°C		F ₂	F ₂	-	-	-	-
43°C		F ₂	F ₂	-	-	-	-

Remarks on application:
Voltage range: without run capacitor: 198 to 242V / with run capacitor: 198 to 254V

Motor

Motor type	CSIR/RSIR/RSCR		
LRA (rated after 4 sec. UL984), HST LST	A	13.1	11.4
Cut in Current, HST LST	A	13.1	15.7
Resistance, main start winding (25°C)	Ω	8.8	19.0

Design

Displacement	cm ³	11.15
Oil quantity (type)	cm ³	300 (polyolester)
Maximum refrigerant charge	g	600
Free gas volume in compressor	cm ³	2360
Weight without electrical equipment	kg	10.9

Dimensions

Height	mm	A	203
		B	197
		B1	-
		B2	-
Suction connector	location/I.D. mm angle	C	8.2 15°
	material comment		Copper Rubber plug
Process connector	location/I.D. mm angle	D	6.2 25°
	material comment		Copper Rubber plug
Discharge connector	location/I.D. mm angle	E	6.2 21°
	material comment		Copper Rubber plug
Oil cooler connector	location/I.D. mm angle	F	-
	material comment		-
Connector tolerance	I.D. mm		±0.09
Remarks:			

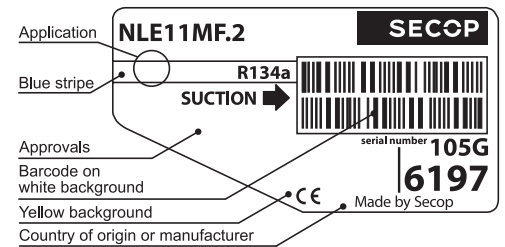

- S = Static cooling normally sufficient
- O = Oil cooling
- F₁ = Fan cooling 1.5 m/s
(compressor compartment temperature equal to ambient temperature)
- F₂ = Fan cooling 3.0 m/s necessary
- SG = Suction gas cooling normally sufficient
- = not applicable in this area

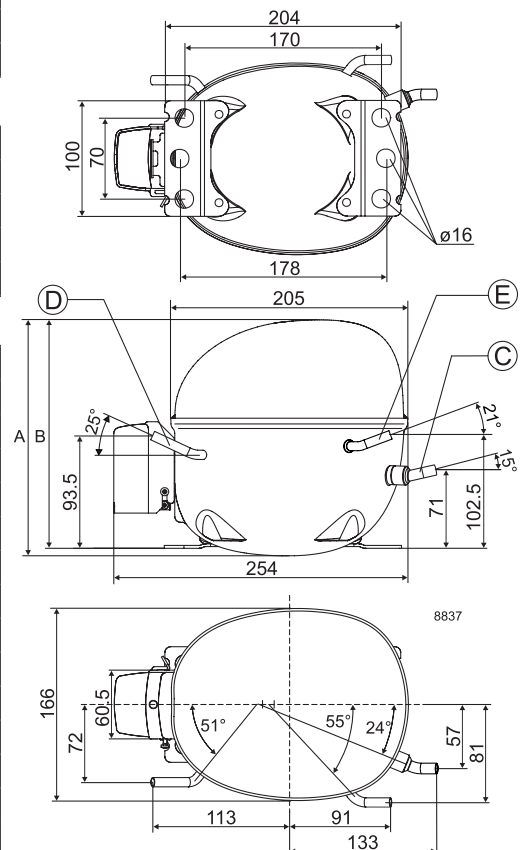

EN 12900 LBP

220V, 50Hz, fan cooling F₂

Evap. temp. in °C	-45	-40	-35	-30	-25	-23.3	-20	-15	-10	-6.7	-5	0	5	7.2	10	15	20
Capacity in W					311	340	404	516	649	749	805	985	1192	1292	1428		
Power cons. in W					224	234	254	286	320	342	354	387	418	431	447		
Current cons. in A					1.72	1.76	1.83	1.92	2.00	2.04	2.07	2.15	2.24	2.28	2.35		
COP in W/W					1.38	1.45	1.59	1.80	2.03	2.19	2.27	2.55	2.85	3.00	3.20		

EN 12900 MBP

220V, 50Hz, fan cooling F₂

Evap. temp. in °C	-45	-40	-35	-30	-25	-23.3	-20	-15	-10	-6.7	-5	0	5	7.2	10	15	20
Capacity in W					290	318	378	484	611	706	759	931	1129	1226	1356		
Power cons. in W					231	241	261	295	331	355	368	405	441	457	476		
Current cons. in A					1.78	1.82	1.89	1.97	2.05	2.11	2.14	2.23	2.35	2.41	2.49		
COP in W/W					1.26	1.32	1.45	1.64	1.85	1.99	2.06	2.30	2.56	2.68	2.85		

ASHRAE LBP

220V, 50Hz, fan cooling F₂

Evap. temp. in °C	-45	-40	-35	-30	-25	-23.3	-20	-15	-10	-6.7	-5	0	5	7.2	10	15	20
Capacity in W					300	331	396	513	654	761	821	1018	1246	1357	1508		
Power cons. in W					224	235	257	293	334	362	377	421	466	485	510		
Current cons. in A					1.79	1.82	1.89	2.00	2.11	2.19	2.24	2.38	2.56	2.65	2.78		
COP in W/W					1.34	1.41	1.54	1.75	1.96	2.10	2.18	2.42	2.68	2.80	2.96		

ASHRAE MBP

220V, 50Hz, fan cooling F₂

Evap. temp. in °C	-45	-40	-35	-30	-25	-23.3	-20	-15	-10	-6.7	-5	0	5	7.2	10	15	20
Capacity in W					268	295	353	457	582	678	731	905	1107	1205	1339		
Power cons. in W					222	232	254	290	330	358	373	416	460	479	503		
Current cons. in A					1.79	1.82	1.89	2.00	2.11	2.19	2.24	2.38	2.56	2.65	2.78		
COP in W/W					1.21	1.27	1.39	1.57	1.76	1.89	1.96	2.17	2.41	2.51	2.66		

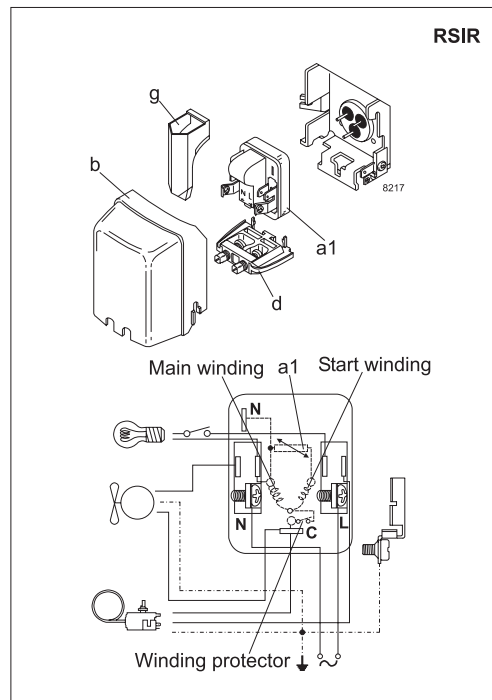
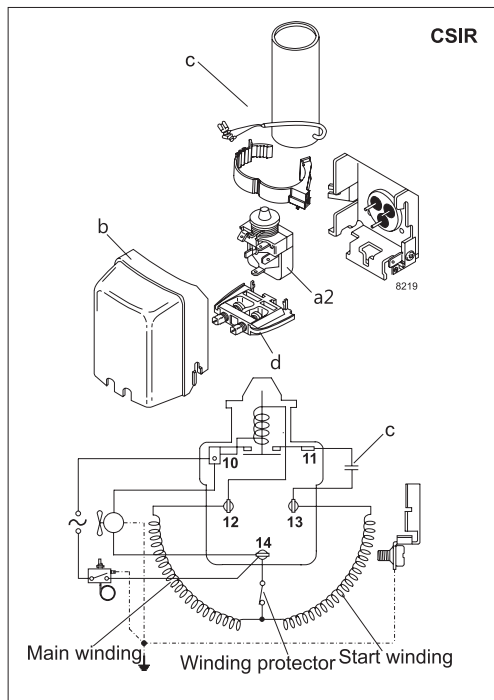

Accessories for	NLE11MF.2	Figure	Code number
ePTC starting device	6.3 mm spade connectors	a1	-
	4.8 mm spade connectors		103N0050
Starting relay	6.3 mm spade connectors	a2	117U6003
Start. capacitor 80 µF	6.3 mm spade connectors	c	117U5015
Cover		b	103N2010
Cord relief		d	103N1010
Protection screen for PTC		g	-

Test conditions	EN 12900		ASHRAE	
	LBP	MBP	LBP	MBP
Condensing temperature	40°C	45°C	54.4°C	54.4°C
Ambient temperature	32°C	32°C	32.2°C	35°C
Suction gas temperature	20°C	20°C	32.2°C	35°C
Liquid temperature	no subcooling		32.2°C	46.1°C

Mounting accessories	Code number	
Bolt joint for one comp.	Ø: 16 mm	118-1917
Bolt joint in quantities	Ø: 16 mm	118-1918
Snap-on in quantities	Ø: 16 mm	118-1919

EN 12900 LBP

 220V, 50Hz, RC 4 µF, ePTC consumption incl., fan cooling F₂

Evap. temp. in °C	-45	-40	-35	-30	-25	-23.3	-20	-15	-10	-6.7	-5	0	5	7.2	10	15	20
Capacity in W					315	345	409	523	658	759	815	998	1208	1309	1447		
Power cons. in W					211	220	239	269	301	322	333	364	393	406	420		
Current cons. in A					1.62	1.66	1.72	1.80	1.88	1.92	1.94	2.02	2.10	2.15	2.21		
COP in W/W					1.49	1.57	1.71	1.94	2.19	2.36	2.45	2.74	3.07	3.23	3.44		

EN 12900 MBP

 220V, 50Hz, RC 4 µF, ePTC consumption incl., fan cooling F₂

Evap. temp. in °C	-45	-40	-35	-30	-25	-23.3	-20	-15	-10	-6.7	-5	0	5	7.2	10	15	20
Capacity in W					294	323	383	491	619	715	769	943	1144	1242	1374		
Power cons. in W					217	227	246	277	311	334	346	381	415	430	448		
Current cons. in A					1.68	1.71	1.77	1.86	1.93	1.98	2.01	2.10	2.21	2.26	2.34		
COP in W/W					1.35	1.42	1.56	1.77	1.99	2.14	2.22	2.48	2.76	2.89	3.07		

ASHRAE LBP

 220V, 50Hz, RC 4 µF, ePTC consumption incl., fan cooling F₂

Evap. temp. in °C	-45	-40	-35	-30	-25	-23.3	-20	-15	-10	-6.7	-5	0	5	7.2	10	15	20
Capacity in W					304	335	401	520	662	771	832	1031	1262	1375	1528		
Power cons. in W					211	221	241	276	314	340	354	396	438	456	479		
Current cons. in A					1.68	1.72	1.78	1.88	1.99	2.06	2.10	2.24	2.41	2.50	2.62		
COP in W/W					1.44	1.52	1.66	1.88	2.11	2.27	2.35	2.60	2.88	3.01	3.19		

ASHRAE MBP

 220V, 50Hz, RC 4 µF, ePTC consumption incl., fan cooling F₂

Evap. temp. in °C	-45	-40	-35	-30	-25	-23.3	-20	-15	-10	-6.7	-5	0	5	7.2	10	15	20
Capacity in W					271	299	358	463	590	687	741	917	1121	1221	1356		
Power cons. in W					209	219	239	273	311	337	350	391	433	451	473		
Current cons. in A					1.68	1.72	1.78	1.88	1.99	2.06	2.10	2.24	2.41	2.50	2.62		
COP in W/W					1.30	1.37	1.50	1.70	1.90	2.04	2.11	2.34	2.59	2.71	2.86		

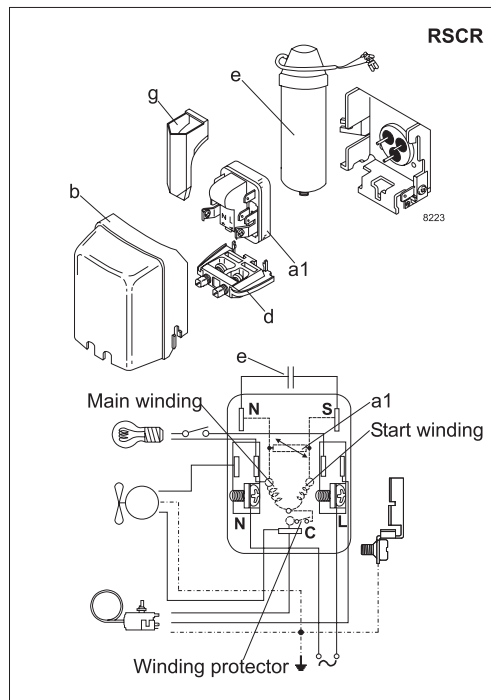

Accessories for	NLE11MF.2	Figure	Code number
ePTC starting device	6.3 mm spade connectors	a1	-
	4.8 mm spade connectors		103N0050
Run capacitor 4 µF (optional)	4.8 mm spade connectors	e	117-7119
Cover		b	103N2010
Cord relief		d	103N1010
Protection screen for PTC		g	-

Test conditions	EN 12900		ASHRAE	
	LBP	MBP	LBP	MBP
Condensing temperature	40°C	45°C	54.4°C	54.4°C
Ambient temperature	32°C	32°C	32.2°C	35°C
Suction gas temperature	20°C	20°C	32.2°C	35°C
Liquid temperature	no subcooling		32.2°C	46.1°C

Mounting accessories	Code number	
Bolt joint for one comp.	Ø: 16 mm	118-1917
Bolt joint in quantities	Ø: 16 mm	118-1918
Snap-on in quantities	Ø: 16 mm	118-1919

Secop accepts no responsibility for possible errors in catalogs, brochures, and other printed material. Secop reserves the right to alter its products without notice. This also applies to products already on order provided that such alterations can be made without consequential changes being necessary to specifications already agreed. All trademarks in this material are the property of the respective companies. Secop and the Secop logotype are trademarks of Secop GmbH. All rights reserved. www.secop.com