

Model

Designation	NLE11MN	115-127V/60Hz 1~	Sales code:	105H5980
-------------	----------------	------------------	-------------	-----------------

Compressor design

Oil type	Polyolester	Refrigerant(s)	R290
Oil viscosity	32cST	Displacement	11,15cm ³ / 0,68cu.in
Oil quantity	298cm ³ / 10,1fl.oz	Compressors on pallet	80
Refr. charge - tech. limit	400g / 14,1oz		
Free gas volume comp.	2360cm ³ / 79,8fl.oz		
Weight	12,14kg / 26,8lbs		
Motor protection	1# internal		
Winding resistance main	0,85Ω (at 25°C)		
Winding resistance aux	4,17Ω (at 25°C)		
Max. winding temp.	125°C / 257°F		
Max. discharge temp.	130°C / 266°F		



General - Configurations with NLE11MN

	Conf. 1	Conf. 2	Conf. 3	Conf. 4
Motorconfiguration	CSIR	CSIR	RSCR	RSCR
Power supply (nominal)	115V/60Hz	115V/60Hz	115V/60Hz	115V/60Hz
Number of phases	1	1	1	1
Voltage range	95-127V	95-135V	95-127V	95-135V
Approvals	UL, CCC	UL, CCC	UL, CCC	UL, CCC
Starting torque	HST	HST	LST	LST
Note	- / -			

Applications with NLE11MN

	Conf. 1	Conf. 2	Conf. 3	Conf. 4
Refrigerant	R290	R290	R290	R290
Application	MBP	MBP	MBP	MBP
System cooling	fan 3m/s	fan 3m/s	fan 3m/s	fan 3m/s
Hot gas defrost	OK	OK	OK	OK
Long interval pull down	OK	OK	OK	OK

Electrical data - Configurations with NLE11MN

	Conf. 1	Conf. 2	Conf. 3	Conf. 4
Starting device type	relay	relay	PTC	PTC
Run capacitor	-/-	-/-	23,5μF	23,5μF
Start capacitor	240μF	240μF	-/-	-/-
LRA (locked rotor amps / 4s)	40,23A	40,23A	41,7A	41,7A
RLA (rated load amps / 1s)	8,37A	8,37A	8,37A	8,37A
Cut in current	40,23A	40,23A	51,83A	51,83A

Model

Designation

NLE11MN

115-127V/60Hz 1~

Sales code:

105H5980

Compressor dimensions

Housing	A Height	203mm / 7,99in
	B Height	197mm / 7,76in
	C Length shell	205mm / 8,07in
	D Length w. cover	254mm / 10in
	E Width	166mm / 6,54in

Connectors		Suction	Discharge	Process
		X	Y	Z
Diameter	[mm]	øi 8,11-8,29	øi 6,41-6,59	øi 6,41-6,59
	(i:inside, o:outside) [in]	øi 0,32-0,33	øi 0,25-0,26	øi 0,25-0,26
Material		copper	copper	copper
Horizontal angle	±2°	0°	0°	0°
Vertical angle	±2°	15°	21°	155°
Position l/h/w	[mm]	132/69/57	94/102/81	-109/94/72
	[in]	5,2/2,7/2,2	3,7/4/3,2	-4,3/3,7/2,8
Straight tube l.	[mm]	12	12	12
	[in]	0,5	0,5	0,5

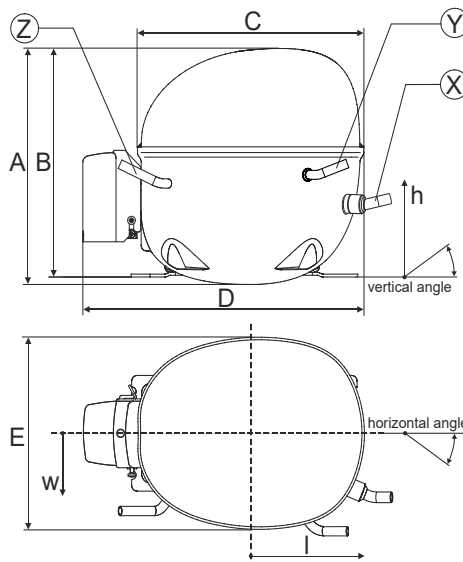

Compressor fixation

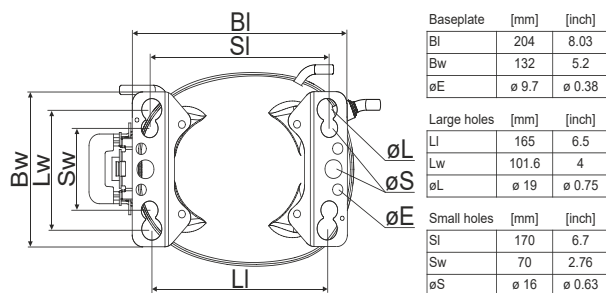

Bolt joint



Snap-on

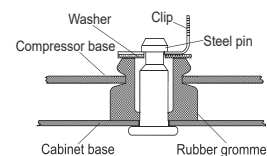

Mounting accessories

	one comp.	multi pack
Bolt joint M6 ø16mm	118-1917	118-1918
Bolt joint ø1/4" ø16mm	118-1946	
Bolt joint ø1/4" ø19mm	118-1949	
Snap-on ø7,3 ø16mm	118-1947	118-1919

Application notes

LRA value on compressor label and datasheet may differ due to different test conditions for UL approval.

Provision for PE Grounding is located at the PE Stamp on the compressor

Model

Designation	NLE11MN	115V/60Hz	Conf. 1	Sales code:	105H5980
-------------	----------------	------------------	----------------	-------------	-----------------

Configuration

Motorconfiguration	CSIR	
Power supply (nominal)	115V/60Hz 1~	
Refrigerant	R290	
Application	MBP	
Voltage range	95-127V	
Starting torque	HST	
Approvals	UL	SA3693
	CCC	

Electrical accessories / wiring diagram

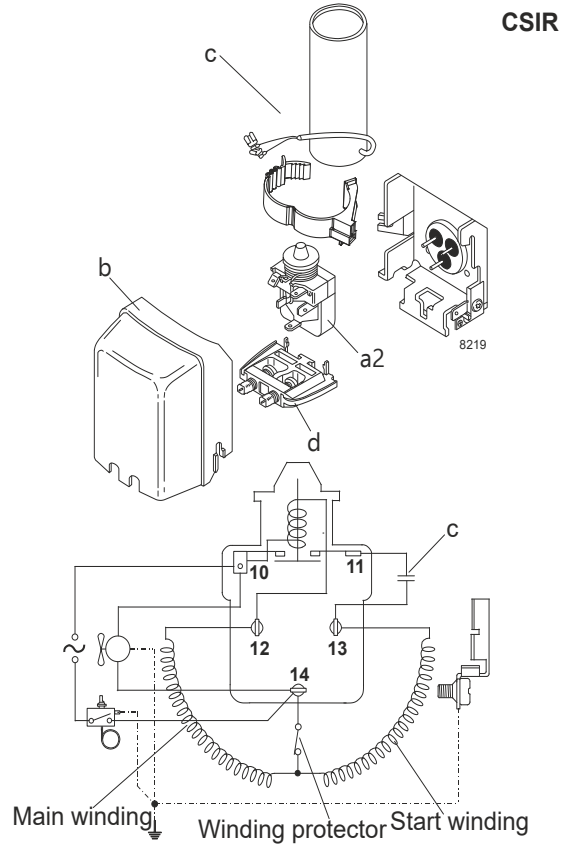

Ambient/ machine room temperatures minimum /maximum

Ambient temperature range: 10 - 43°C / 50 - 110°F

Machine room temperature range: 10 - 48°C / 50 - 119°F

Compressor cooling: fan 3m/s

Operation pressure range

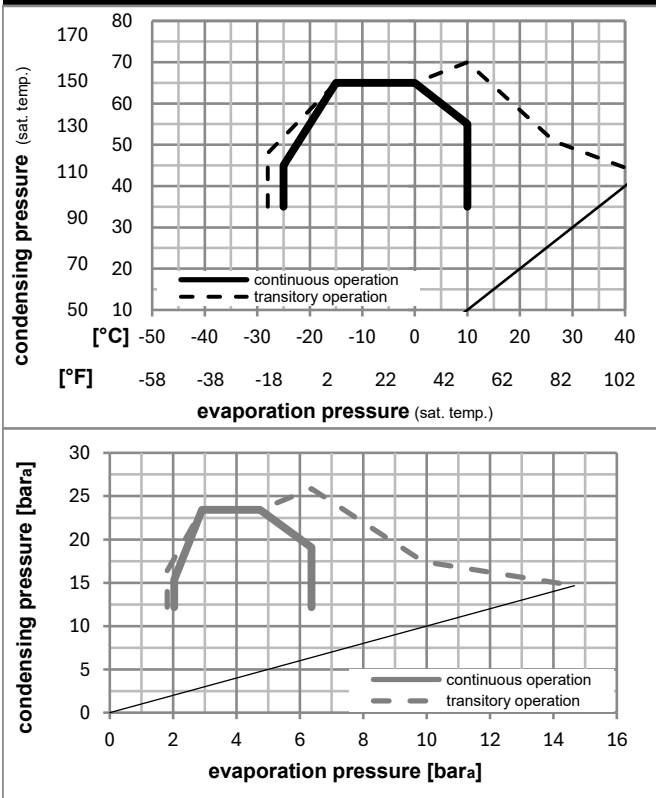

Components

a2	relay	117U7020
c	start capacitor (240µF, 6,3mm)	117U5073
b	plastic cover	103N2011
d	cord relief	103N1010

Alternative components

a2	relay	117U7020
c	start capacitor (240µF, 15kOhm)	117U5034
b	plastic cover	103N2011
d	cord relief	103N1010

Model

Designation	NLE11MN	115V/60Hz	Conf. 1	Sales code:	105H5980
-------------	----------------	------------------	----------------	-------------	-----------------

Optimization + standard conditions

R290, 115V/60Hz, CSIR, fan 3m/s, UL, CCC

		Evaporating pressure (saturation temperature)				Condensing pressure (saturation temperature)			Return gas temp.			Liquid temp.			Cooling capacity			COP	EER	Power consumption			ASHRAE MBP
		pe	pc	RGT	Tliq	[W]	[Btu/h]	[kcal/h]	[W/W]	[Btu/Wh]	[kcal/Wh]	P1	I	m	[W]	[A]	[kg/h]	cecomaf MBP					
[°C]	[°F]																						
-7	20	54	130	35	95	46	115	1202,7	4107	1035,1	2,04	6,97	1,76	589,1	7,15	13,72							
-10	14	55	131	32	90	55	131	959,7	3278	825,9	1,71	5,83	1,47	561,8	6,96	12,14							
-10	14	45	113	20	68	45	113	1058,4	3615	910,9	2,04	6,96	1,75	519,1	6,77	12,99							
-7	20	49	120	18	65	49	120	1124,6	3841	967,8	2,00	6,83	1,72	562,1	7,01	14,60							
-10	14	45	113	32	90	45	113	1101,8	3763	948,2	2,12	7,25	1,83	519,1	6,77	12,61	opt						
-25	-13	45	113	32	90	45	113	594,0	2029	511,2	1,45	4,94	1,24	410,8	6,09	6,70	opt						

Performance tables

R290, 115V/60Hz, CSIR, fan 3m/s, UL, CCC

	pe		Cooling capacity			COP	EER		P1	I	m
	[°C]	[°F]	[W]	[Btu/h]	[kcal/h]	[W/W]	[Btu/Wh]	[kcal/Wh]	[W]	[A]	[kg/h]
[°C / °F]	-25	-13	594,0	2029	511,2	1,45	4,94	1,24	410,8	6,09	6,70
cond. pressure	-23	-10	642,1	2193	552,6	1,52	5,18	1,31	422,9	6,17	7,25
pc= 45/113	-15	5	912,1	3115	784,9	1,89	6,44	1,62	483,7	6,54	10,38
return gas temp.	-9	15	1124,4	3840	967,7	2,15	7,34	1,85	523,0	6,79	12,87
RGT= 32/90	0	32	1558,6	5323	1341,3	2,67	9,11	2,29	584,5	7,21	18,08
liquid temp	4,4	40	1799,8	6147	1548,9	2,95	10,08	2,54	609,9	7,38	21,03
Tliq= 45/113	10	50	2139,1	7305	1840,9	3,36	11,46	2,89	637,3	7,58	25,28
[°C / °F]	-25	-13	498,1	1701	428,7	1,18	4,03	1,01	422,5	6,09	6,20
cond. pressure	-23	-10	542,7	1853	467,1	1,24	4,23	1,07	438,1	6,18	6,77
pc= 55/131	-15	5	789,0	2695	679,0	1,53	5,22	1,32	515,9	6,66	9,92
return gas temp	-9	15	979,9	3347	843,3	1,73	5,90	1,49	566,8	7,00	12,40
RGT= 32/90	0	32	1367,3	4670	1176,7	2,11	7,20	1,82	648,2	7,57	17,56
liquid temp	4,4	40	1582,1	5403	1361,5	2,32	7,91	1,99	683,0	7,83	20,49
Tliq= 55/131	10	50	1884,1	6435	1621,5	2,61	8,91	2,24	722,4	8,13	24,70

Model

Designation	NLE11MN	115V/60Hz	Conf. 2	Sales code:	105H5980
-------------	----------------	------------------	----------------	-------------	-----------------

Configuration

Motorconfiguration	CSIR	
Power supply (nominal)	115V/60Hz 1~	
Refrigerant	R290	
Application	MBP	
Voltage range	95-135V	
Starting torque	HST	
Approvals	UL	SA3693
	CCC	

Electrical accessories / wiring diagram

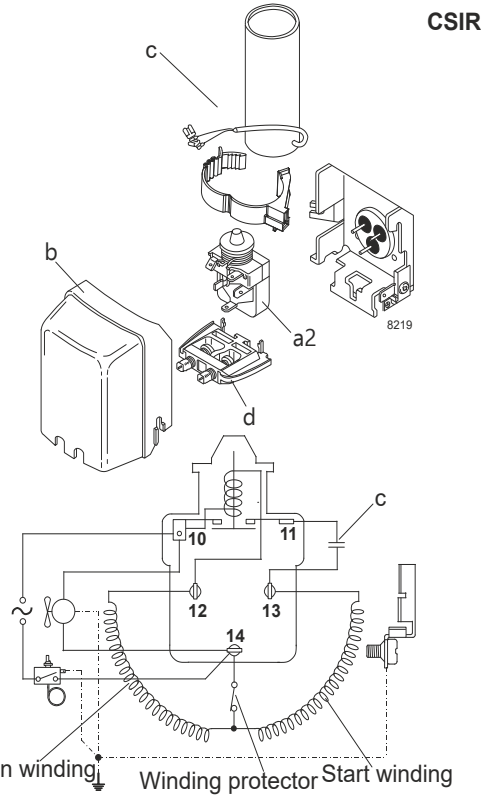

Ambient/ machine room temperatures minimum /maximum

Ambient temperature range: 10 - 43°C / 50 - 110°F

Machine room temperature range: 10 - 48°C / 50 - 119°F

Compressor cooling: fan 3m/s

Operation pressure range

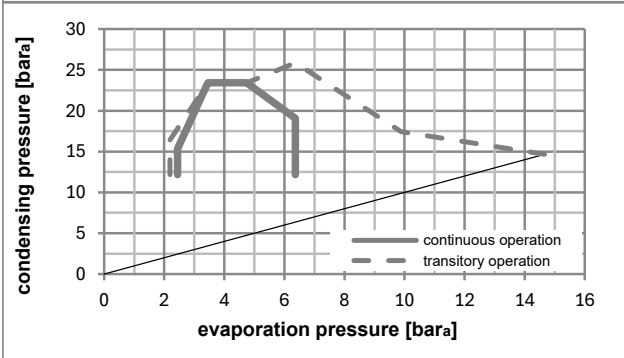
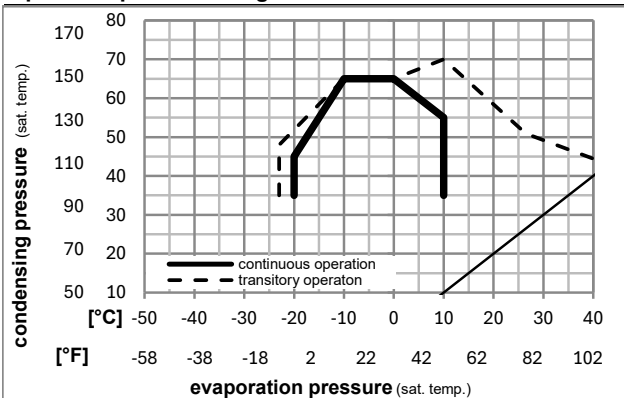

Components

a2	relay	117U7020
c	start capacitor (240μF, 6,3mm)	117U5073
b	plastic cover	103N2011
d	cord relief	103N1010

Alternative components

a2	relay	117U7020
c	start capacitor (240μF, 15kOhm)	117U5034
b	plastic cover	103N2011
d	cord relief	103N1010

Model

Designation	NLE11MN	115V/60Hz	Conf. 2	Sales code:	105H5980
-------------	----------------	------------------	----------------	-------------	-----------------

Optimization + standard conditions

R290, 115V/60Hz, CSIR, fan 3m/s, UL, CCC

		Evaporating pressure (saturation temperature)				Condensing pressure (saturation temperature)			Return gas temp.		Liquid temp.		Cooling capacity			COP	EER	Power consumption		
		pe	pc	RGT	Tliq	[W]	[Btu/h]	[kcal/h]	[W/W]	[Btu/Wh]	[kcal/Wh]	P1	I	Current consumption		Ref. mass flow				
[°C]	[°F]	[°C]	[°F]	[°C]	[°F]	[W]	[Btu/h]	[kcal/h]	[W/W]	[Btu/Wh]	[kcal/Wh]	[W]	[A]	[A]	[kg/h]					
-7	20	54	130	35	95	1202,7	4107	1035,1	2,04	6,97	1,76	589,1	7,15	13,72					ASHRAE MBP	
-10	14	55	131	32	90	959,7	3278	825,9	1,71	5,83	1,47	561,8	6,96	12,14					cecomaf MBP	
-10	14	45	113	20	68	1058,4	3615	910,9	2,04	6,96	1,75	519,1	6,77	12,99					EN12900 MBP	
-7	20	49	120	18	65	1124,6	3841	967,8	2,00	6,83	1,72	562,1	7,01	14,60					ARI540 MBP	
-10	14	45	113	32	90	1101,8	3763	948,2	2,12	7,25	1,83	519,1	6,77	12,61					opt	
-25	-13	45	113	32	90	594,0	2029	511,2	1,45	4,94	1,24	410,8	6,09	6,70					opt	

Performance tables

R290, 115V/60Hz, CSIR, fan 3m/s, UL, CCC

	pe		Cooling capacity			COP	EER	P1			I	m
	[°C]	[°F]	[W]	[Btu/h]	[kcal/h]	[W/W]	[Btu/Wh]	[kcal/Wh]	[W]	[A]	[kg/h]	
[°C / °F]	-20	-4	743,8	2540	640,1	1,66	5,68	1,43	447,3	6,31	8,42	
cond. pressure	-15	5	912,1	3115	784,9	1,89	6,44	1,62	483,7	6,54	10,38	
pc= 45/113	-9	15	1124,4	3840	967,7	2,15	7,34	1,85	523,0	6,79	12,87	
return gas temp.	-7	20	1241,9	4241	1068,8	2,29	7,83	1,97	541,9	6,92	14,27	
RGT= 32/90	0	32	1558,6	5323	1341,3	2,67	9,11	2,29	584,5	7,21	18,08	
liquid temp	4,4	40	1799,8	6147	1548,9	2,95	10,08	2,54	609,9	7,38	21,03	
Tliq= 45/113	10	50	2139,1	7305	1840,9	3,36	11,46	2,89	637,3	7,58	25,28	
[°C / °F]	-20	-4	636,2	2173	547,5	1,36	4,63	1,17	469,2	6,37	7,96	
cond. pressure	-15	5	789,0	2695	679,0	1,53	5,22	1,32	515,9	6,66	9,92	
pc= 55/131	-9	15	979,9	3347	843,3	1,73	5,90	1,49	566,8	7,00	12,40	
return gas temp	-7	20	1085,0	3705	933,8	1,83	6,26	1,58	591,6	7,17	13,79	
RGT= 32/90	0	32	1367,3	4670	1176,7	2,11	7,20	1,82	648,2	7,57	17,56	
liquid temp	4,4	40	1582,1	5403	1361,5	2,32	7,91	1,99	683,0	7,83	20,49	
Tliq= 55/131	10	50	1884,1	6435	1621,5	2,61	8,91	2,24	722,4	8,13	24,70	

Model

Designation	NLE11MN	115V/60Hz	Conf. 3	Sales code:	105H5980
-------------	----------------	------------------	----------------	-------------	-----------------

Configuration

Motorconfiguration	RSCR	
Power supply (nominal)	115V/60Hz 1~	
Refrigerant	R290	
Application	MBP	
Voltage range	95-127V	
Starting torque	LST	
Approvals	UL	SA3693
	CCC	

Electrical accessories / wiring diagram

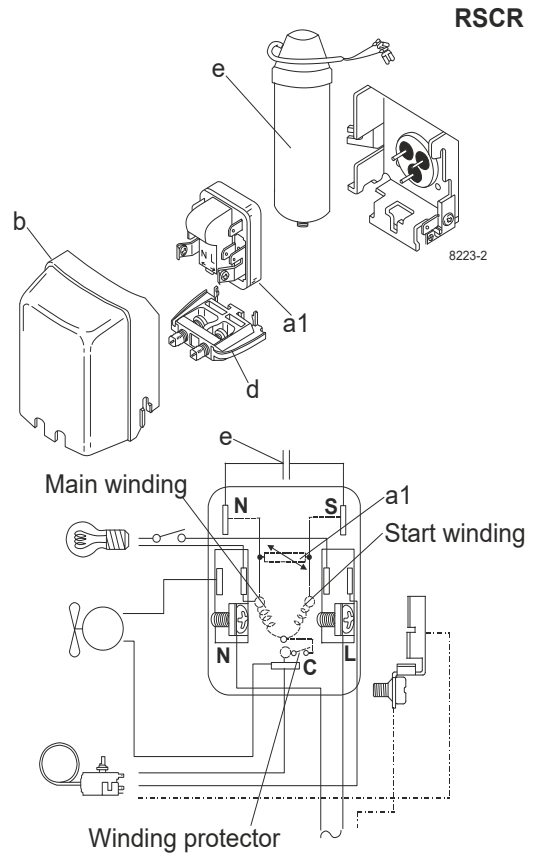

Ambient/ machine room temperatures minimum /maximum

Ambient temperature range:	10 - 43°C / 50 - 110°F
Machine room temperature range:	10 - 48°C / 50 - 119°F
Compressor cooling:	fan 3m/s

Operation pressure range

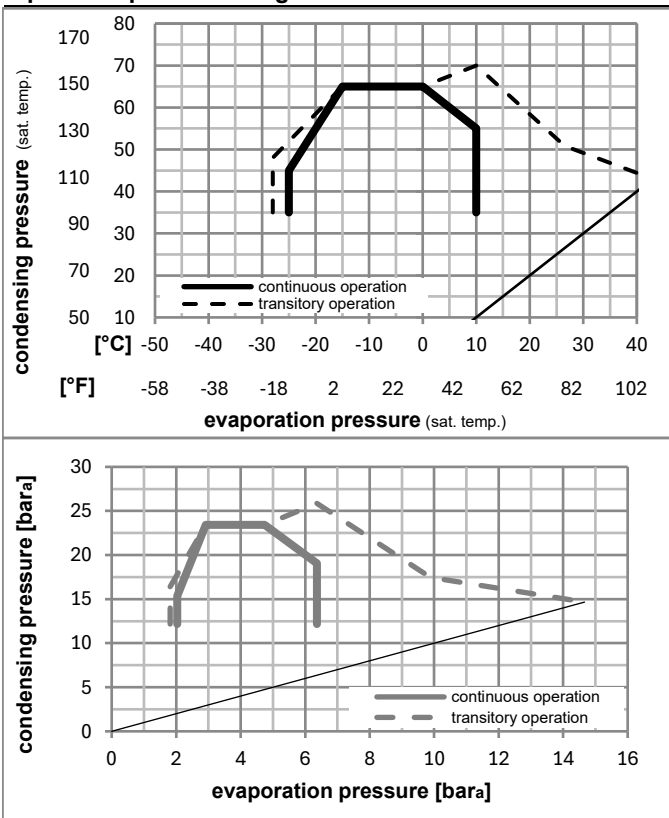

Components

a1	e-PTC starter	103N0058
e	run capacitor (23,5μF, 6.3mm)	117-7114
b	plastic cover	103N2011
d	cord relief	103N1010
	bracket for run capacitor	117-0300
	screw M4x8mm	117-0301

Model

Designation	NLE11MN	115V/60Hz	Conf. 3	Sales code:	105H5980
-------------	----------------	------------------	----------------	-------------	-----------------

Optimization + standard conditions

R290, 115V/60Hz, RSCR, fan 3m/s, UL, CCC

		Evaporating pressure (saturation temperature)				Condensing pressure (saturation temperature)			Return gas temp.			Liquid temp.			Cooling capacity			COP	EER	Power consumption			
		pe	pc	RGT	Tliq	[W]	[Btu/h]	[kcal/h]	[W/W]	[Btu/Wh]	[kcal/Wh]	P1	I	m	[W]	[A]	[kg/h]						
[°C]	[°F]	[°C]	[°F]	[°C]	[°F]																		
-7	20	54	130	35	95	46	115	1221,4	4171	1051,2	2,20	7,51	1,89	555,5	6,74	13,93	ASHRAE MBP						
-10	14	55	131	32	90	55	131	975,1	3330	839,2	1,84	6,29	1,58	529,7	6,56	12,33	cecomaf MBP						
-10	14	45	113	20	68	45	113	1067,3	3645	918,5	2,18	7,45	1,88	489,5	6,38	13,10	EN12900 MBP						
-7	20	49	120	18	65	49	120	1138,5	3888	979,8	2,15	7,34	1,85	530,0	6,61	14,78	ARI540 MBP						
-10	14	45	113	32	90	45	113	1111,1	3795	956,3	2,27	7,75	1,95	489,5	6,38	12,71	opt						
-25	-13	45	113	32	90	45	113	598,4	2044	515,0	1,54	5,28	1,33	387,4	5,75	6,75	opt						

Performance tables

R290, 115V/60Hz, RSCR, fan 3m/s, UL, CCC

	pe		Cooling capacity			COP	EER	P1	I	m	
	[°C]	[°F]	[W]	[Btu/h]	[kcal/h]	[W/W]	[Btu/Wh]	[kcal/Wh]	[W]	[A]	[kg/h]
[°C / °F]	-25	-13	598,4	2044	515,0	1,54	5,28	1,33	387,4	5,75	6,75
cond. pressure	-23	-10	647,1	2210	556,9	1,62	5,54	1,40	398,8	5,81	7,31
pc= 45/113	-15	5	919,7	3141	791,5	2,02	6,89	1,74	456,0	6,17	10,46
return gas temp.	-9	15	1133,9	3872	975,8	2,30	7,85	1,98	493,1	6,40	12,98
RGT= 32/90	0	32	1572,1	5369	1353,0	2,85	9,74	2,45	551,1	6,79	18,23
liquid temp	4,4	40	1815,8	6201	1562,7	3,16	10,78	2,72	575,1	6,96	21,22
Tliq= 45/113	10	50	2158,8	7373	1857,9	3,59	12,27	3,09	601,0	7,14	25,51
[°C / °F]	-25	-13	508,1	1735	437,3	1,28	4,36	1,10	398,4	5,75	6,33
cond. pressure	-23	-10	553,3	1889	476,1	1,34	4,57	1,15	413,0	5,83	6,90
pc= 55/131	-15	5	802,5	2741	690,7	1,65	5,63	1,42	486,5	6,28	10,09
return gas temp	-9	15	995,5	3400	856,8	1,86	6,36	1,60	534,5	6,60	12,60
RGT= 32/90	0	32	1387,3	4738	1193,9	2,27	7,75	1,95	611,2	7,13	17,82
liquid temp	4,4	40	1604,7	5480	1381,0	2,49	8,51	2,14	644,0	7,38	20,78
Tliq= 55/131	10	50	1910,7	6525	1644,3	2,81	9,58	2,41	681,1	7,67	25,05

Model

Designation	NLE11MN	115V/60Hz	Conf. 4	Sales code:	105H5980
-------------	----------------	------------------	----------------	-------------	-----------------

Configuration

Motorconfiguration	RSCR	
Power supply (nominal)	115V/60Hz 1~	
Refrigerant	R290	
Application	MBP	
Voltage range	95-135V	
Starting torque	LST	
Approvals	UL	SA3693
	CCC	

Electrical accessories / wiring diagram

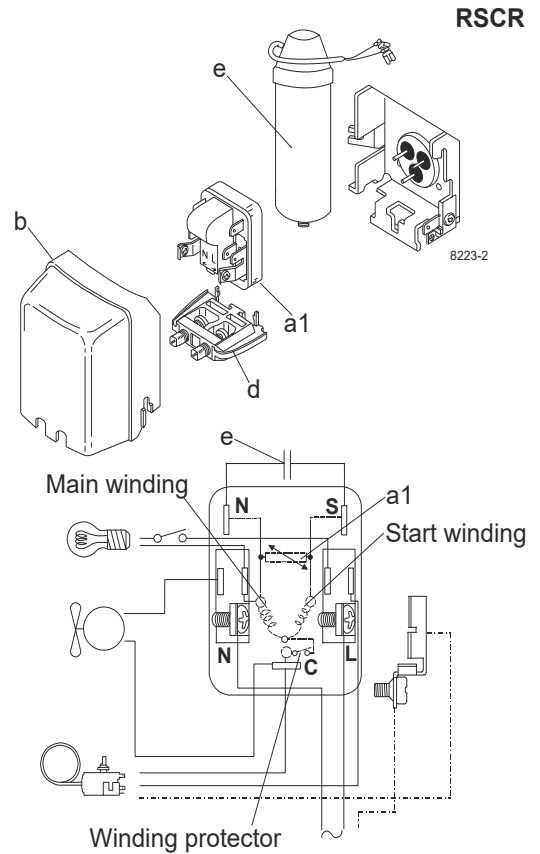

Ambient/ machine room temperatures minimum /maximum

Ambient temperature range:	10 - 43°C / 50 - 110°F
Machine room temperature range:	10 - 48°C / 50 - 119°F
Compressor cooling:	fan 3m/s

Operation pressure range

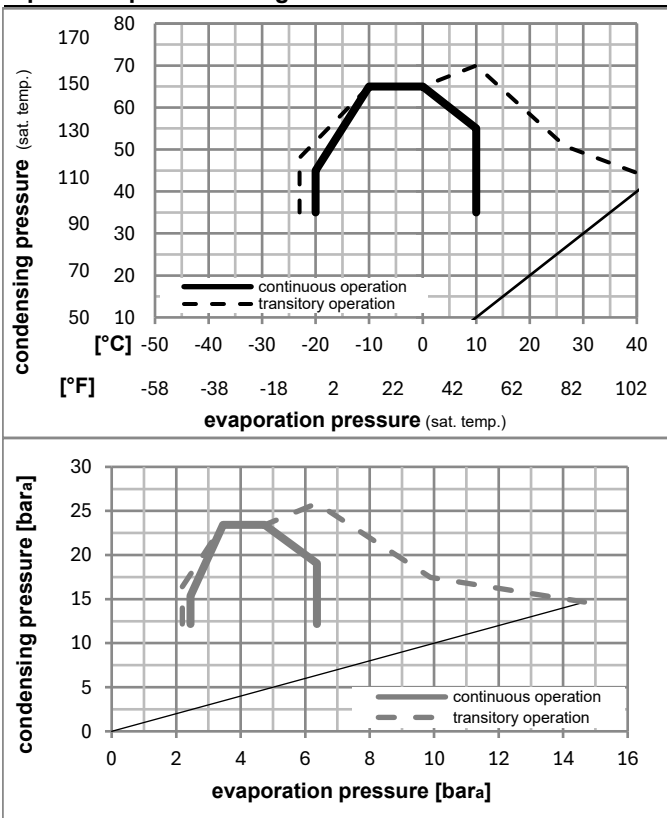

Components

a1	e-PTC starter	103N0058
e	run capacitor (23,5μF, 6.3mm)	117-7114
b	plastic cover	103N2011
d	cord relief	103N1010
	bracket for run capacitor	117-0300
	screw M4x8mm	117-0301

Model

Designation	NLE11MN	115V/60Hz	Conf. 4	Sales code:	105H5980
-------------	----------------	------------------	----------------	-------------	-----------------

Optimization + standard conditions

R290, 115V/60Hz, RSCR, fan 3m/s, UL, CCC

		Evaporating pressure (saturation temperature)				Condensing pressure (saturation temperature)			Return gas temp.			Liquid temp.			Cooling capacity			COP	EER	Power consumption			
		pe	pc	RGT	Tliq	[W]	[Btu/h]	[kcal/h]	[W/W]	[Btu/Wh]	[kcal/Wh]	P1	I	m	[W]	[A]	[kg/h]						
[°C]	[°F]	[°C]	[°F]	[°C]	[°F]																		
-7	20	54	130	35	95	46	115	1221,4	4171	1051,2	2,20	7,51	1,89	555,5	6,74	13,93	ASHRAE MBP						
-10	14	55	131	32	90	55	131	975,1	3330	839,2	1,84	6,29	1,58	529,7	6,56	12,33	cecomaf MBP						
-10	14	45	113	20	68	45	113	1067,3	3645	918,5	2,18	7,45	1,88	489,5	6,38	13,10	EN12900 MBP						
-7	20	49	120	18	65	49	120	1138,5	3888	979,8	2,15	7,34	1,85	530,0	6,61	14,78	ARI540 MBP						
-10	14	45	113	32	90	45	113	1111,1	3795	956,3	2,27	7,75	1,95	489,5	6,38	12,71	opt						
-25	-13	45	113	32	90	45	113	598,4	2044	515,0	1,54	5,28	1,33	387,4	5,75	6,75	opt						

Performance tables

R290, 115V/60Hz, RSCR, fan 3m/s, UL, CCC

	pe		Cooling capacity			COP	EER	P1			I	m
	[°C]	[°F]	[W]	[Btu/h]	[kcal/h]	[W/W]	[Btu/Wh]	[kcal/Wh]	[W]	[A]	[kg/h]	
[°C / °F]	-20	-4	749,9	2561	645,3	1,78	6,07	1,53	421,8	5,95	8,49	
cond. pressure	-15	5	919,7	3141	791,5	2,02	6,89	1,74	456,0	6,17	10,46	
pc= 45/113	-9	15	1133,9	3872	975,8	2,30	7,85	1,98	493,1	6,40	12,98	
return gas temp.	-7	20	1252,4	4277	1077,8	2,45	8,37	2,11	511,0	6,52	14,39	
RGT= 32/90	0	32	1572,1	5369	1353,0	2,85	9,74	2,45	551,1	6,79	18,23	
liquid temp	4,4	40	1815,8	6201	1562,7	3,16	10,78	2,72	575,1	6,96	21,22	
Tliq= 45/113	10	50	2158,8	7373	1857,9	3,59	12,27	3,09	601,0	7,14	25,51	
[°C / °F]	-20	-4	647,9	2213	557,6	1,46	5,00	1,26	442,5	6,01	8,10	
cond. pressure	-15	5	802,5	2741	690,7	1,65	5,63	1,42	486,5	6,28	10,09	
pc= 55/131	-9	15	995,5	3400	856,8	1,86	6,36	1,60	534,5	6,60	12,60	
return gas temp	-7	20	1101,8	3763	948,2	1,98	6,75	1,70	557,8	6,76	14,00	
RGT= 32/90	0	32	1387,3	4738	1193,9	2,27	7,75	1,95	611,2	7,13	17,82	
liquid temp	4,4	40	1604,7	5480	1381,0	2,49	8,51	2,14	644,0	7,38	20,78	
Tliq= 55/131	10	50	1910,7	6525	1644,3	2,81	9,58	2,41	681,1	7,67	25,05	