

Model

Designation	NLE11MNT	208-230V/60Hz 1~	Sales code:	105H6199
-------------	-----------------	------------------	-------------	-----------------

Compressor design

Oil type	Polyolester	Refrigerant(s)	R290
Oil viscosity	32cST	Displacement	11,15cm ³ / 0,68cu.in
Oil quantity	298cm ³ / 10,1fl.oz	Compressors on pallet	80
Refr. charge - tech. limit	400g / 14,1oz		
Free gas volume comp.	2360cm ³ / 79,8fl.oz		
Weight	12,2kg / 26,9lbs		
Motor protection	1# internal		
Winding resistance main	4,33Ω (at 25°C)		
Winding resistance aux	15,24Ω (at 25°C)		
Max. winding temp.	125°C / 257°F		
Max. discharge temp.	130°C / 266°F		



General - Configurations with NLE11MNT

	Conf. 1	Conf. 2	Conf. 3	Conf. 4	Conf. 5
Motorconfiguration	CSIR	CSIR	RSCR	RSIR	RSIR
Power supply (nominal)	208-230V/60Hz	208-230V/60Hz	208-230V/60Hz	208-230V/60Hz	208-230V/60Hz
Number of phases	1	1	1	1	1
Voltage range	187-253V	187-242V	187-253V	187-253V	187-242V
Approvals	UL, CB	UL, CB	UL, CB	UL, CB	UL, CB
Starting torque	HST	HST	LST	LST	LST
Note	- / -				

Applications with NLE11MNT

	Conf. 1	Conf. 2	Conf. 3	Conf. 4	Conf. 5
Refrigerant	R290	R290	R290	R290	R290
Application	MBP	MBP	MBP	MBP	MBP
System cooling	fan 3m/s	fan 3m/s	fan 3m/s	fan 3m/s	fan 3m/s
Hot gas defrost	OK	OK	OK	OK	OK
Long interval pull down	OK	OK	OK	OK	OK

Electrical data - Configurations with NLE11MNT

	Conf. 1	Conf. 2	Conf. 3	Conf. 4	Conf. 5
Starting device type	relay	relay	PTC	PTC	PTC
Run capacitor	- / -	- / -	4μF	- / -	- / -
Start capacitor	60μF	60μF	- / -	- / -	- / -
LRA (locked rotor amps / 4s)	18,17A	18,17A	17,49A	17,49A	17,49A
RLA (rated load amps / 1s)	3,4A	3,4A	2,83A	3,4A	3,4A
Cut in current	18,17A	18,17A	21,69A	21,69A	21,69A

Model

Designation

NLE11MNT

208-230V/60Hz 1~

Sales code:

105H6199

Compressor dimensions

Housing	A Height	203mm / 7,99in
	B Height	197mm / 7,76in
	C Length shell	205mm / 8,07in
	D Length w. cover	254mm / 10in
	E Width	166mm / 6,54in

Connectors		Suction	Discharge	Process
		X	Y	Z
Diameter	[mm]	øi 8,11-8,29	øi 6,41-6,59	øi 6,41-6,59
	(i:inside, o:outside) [in]	øi 0,32-0,33	øi 0,25-0,26	øi 0,25-0,26
Material		copper	copper	copper
Horizontal angle	±2°	0°	0°	0°
Vertical angle	±2°	15°	21°	155°
Position l/h/w	[mm]	132/69/57	94/102/81	-109/94/72
	[in]	5,2/2,7/2,2	3,7/4/3,2	-4,3/3,7/2,8
Straight tube l.	[mm]	12	12	12
	[in]	0,5	0,5	0,5

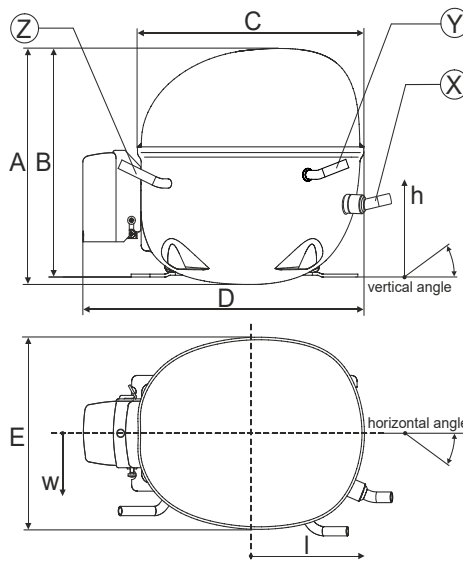

Compressor fixation



Bolt joint



Snap-on

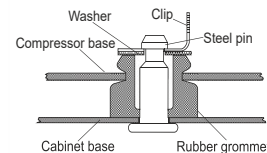

Mounting accessories

Mounting accessories	one comp.	multi pack
Bolt joint M6 ø16mm	118-1917	118-1918
Bolt joint ø1/4" ø16mm	118-1946	
Bolt joint ø1/4" ø19mm	118-1949	
Snap-on ø7,3 ø16mm	118-1947	118-1919

Application notes

LRA value on compressor label and datasheet may differ due to different test conditions for UL approval.

Provision for PE Grounding is located at the PE Stamp on the compressor

Model

Designation	NLE11MNT	208-230V/60Hz	Conf. 1	Sales code:	105H6199
-------------	-----------------	----------------------	---------	-------------	-----------------

Configuration

Motorconfiguration	CSIR	
Power supply (nominal)	208-230V/60Hz 1~	
Refrigerant	R290	
Application	MBP	
Voltage range	187-253V	
Starting torque	HST	
Approvals	UL	SA3693
	CB	

Electrical accessories / wiring diagram

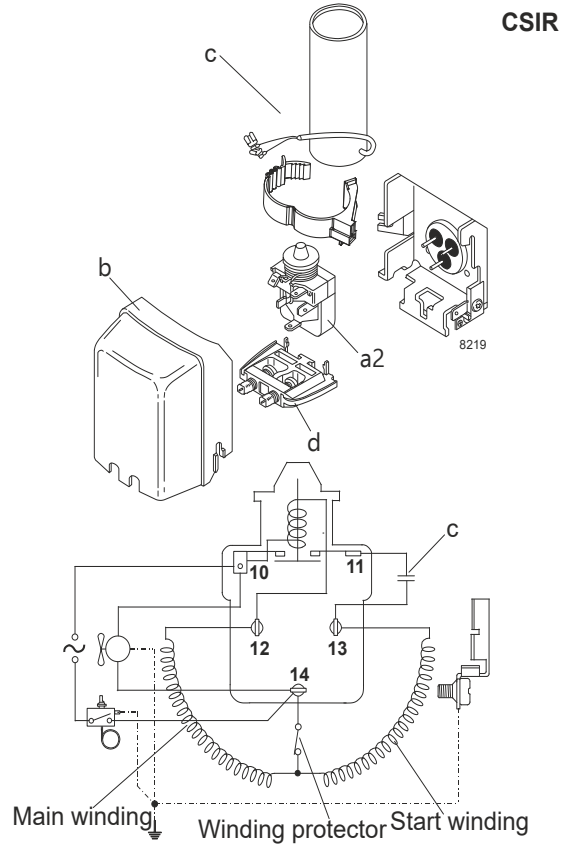

Ambient/ machine room temperatures minimum /maximum

Ambient temperature range: 10 - 43°C / 50 - 110°F

Machine room temperature range: 10 - 48°C / 50 - 119°F

Compressor cooling: fan 3m/s

Operation pressure range

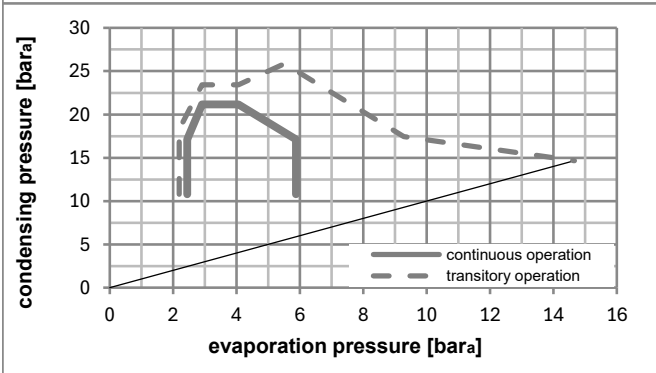
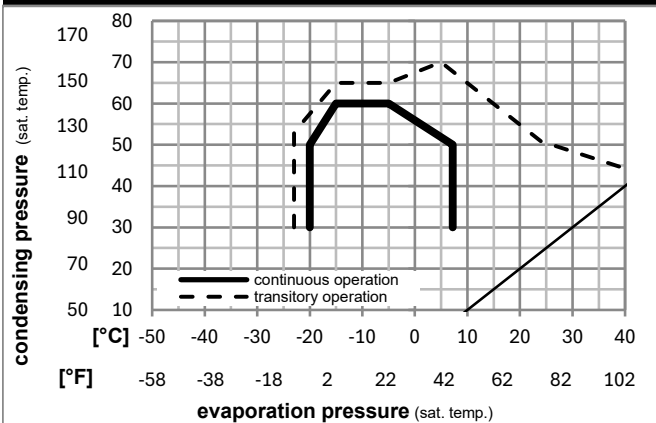

Components

a2	current relay	117U7050
c	start capacitor (60µF)	117U5014
b	plastic cover	103N2011
d	cord relief	103N1010

Model

Designation **NLE11MNT** **208-230V/60Hz** Conf. 1 Sales code: **105H6199**

Optimization + standard conditions

R290, 230V/60Hz, CSIR, fan 3m/s, UL, CB

		Evaporating pressure (saturation temperature)				Condensing pressure (saturation temperature)			Return gas temp.			Liquid temp.			Cooling capacity			COP	EER	Power consumption			ASHRAE MBP
		pe	pc	RGT	Tliq	[W]	[Btu/h]	[kcal/h]	[W/W]	[Btu/Wh]	[kcal/Wh]	P1	I	m	[W]	[A]	[kg/h]						
[°C]	[°F]																						
-7	20	54	130	35	95	46	115	1177,6	4022	1013,4	2,02	6,89	1,74	583,8	3,29	13,43							
-10	14	55	131	32	90	55	131	942,4	3219	811,1	1,70	5,79	1,46	555,6	3,19	11,92					cecomaf MBP		
-10	14	45	113	20	68	45	113	1038,2	3546	893,5	2,03	6,93	1,75	511,8	3,03	12,75					EN12900 MBP		
-7	20	49	120	18	65	49	120	1102,4	3765	948,7	1,98	6,76	1,70	557,2	3,19	14,31					ARI540 MBP		
-10	14	45	113	32	90	45	113	1080,8	3691	930,2	2,11	7,21	1,82	511,8	3,03	12,36					opt		
-25	-13	45	113	32	90	45	113	587,5	2006	505,6	1,52	5,21	1,31	385,3	2,57	6,63					opt		

Performance tables

R290, 230V/60Hz, CSIR, fan 3m/s, UL, CB

	pe		Cooling capacity			COP	EER		P1	I	m
	[°C]	[°F]	[W]	[Btu/h]	[kcal/h]	[W/W]	[Btu/Wh]	[kcal/Wh]	[W]	[A]	[kg/h]
[°C / °F]	-20	-4	731,5	2498	629,5	1,70	5,82	1,47	429,3	2,73	8,28
cond. pressure	-15	5	895,1	3057	770,3	1,90	6,48	1,63	471,9	2,88	10,18
pc= 45/113	-9	15	1102,9	3767	949,2	2,14	7,30	1,84	516,0	3,04	12,63
return gas temp.	-7	20	1218,1	4160	1048,3	2,27	7,76	1,96	536,2	3,12	13,99
RGT= 32/90	-4	25	1341,2	4581	1154,3	2,42	8,26	2,08	554,8	3,18	15,47
liquid temp	0	32	1527,9	5218	1314,9	2,64	9,03	2,28	577,8	3,27	17,72
Tliq= 45/113	7,2	45	1922,4	6565	1654,4	3,16	10,78	2,72	608,8	3,38	22,59
[°C / °F]	-20	-4	637,6	2178	548,7	1,39	4,76	1,20	457,2	2,83	7,97
cond. pressure	-15	5	780,5	2666	671,7	1,54	5,25	1,32	507,4	3,01	9,81
pc= 55/131	-9	15	961,7	3284	827,6	1,71	5,86	1,48	560,8	3,20	12,17
return gas temp	-7	20	1062,1	3627	914,1	1,81	6,19	1,56	586,1	3,30	13,50
RGT= 32/90	-4	25	1169,6	3994	1006,6	1,92	6,55	1,65	610,1	3,38	14,93
liquid temp	0	32	1332,8	4552	1147,0	2,08	7,10	1,79	641,0	3,49	17,12
Tliq= 55/131	7,2	45	1678,8	5733	1444,8	2,44	8,33	2,10	688,2	3,66	21,87

Model

Designation	NLE11MNT	208-230V/60Hz	Conf. 2	Sales code:	105H6199
-------------	-----------------	----------------------	----------------	-------------	-----------------

Configuration

Motorconfiguration	CSIR	
Power supply (nominal)	208-230V/60Hz 1~	
Refrigerant	R290	
Application	MBP	
Voltage range	187-242V	
Starting torque	HST	
Approvals	UL	SA3693
	CB	

Electrical accessories / wiring diagram

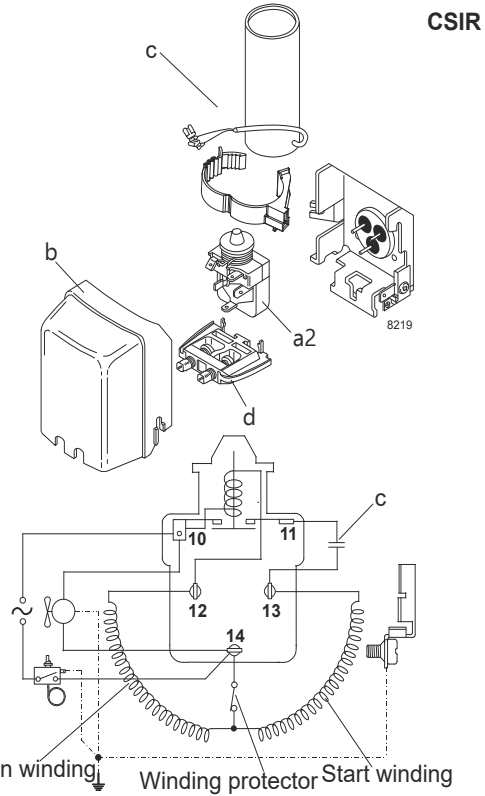

Ambient/ machine room temperatures minimum /maximum

Ambient temperature range: 10 - 43°C / 50 - 110°F

Machine room temperature range: 10 - 48°C / 50 - 119°F

Compressor cooling: fan 3m/s

Operation pressure range

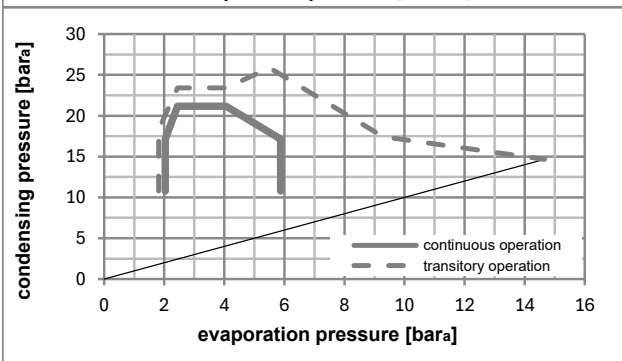
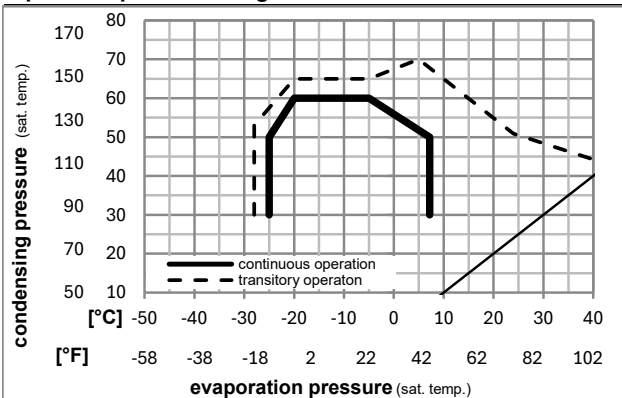

Components

a2	current relay	117U7050
c	start capacitor (60μF)	117U5014
b	plastic cover	103N2011
d	cord relief	103N1010

Model

Designation **NLE11MNT** **208-230V/60Hz** Conf. 2 Sales code: **105H6199**

Optimization + standard conditions

R290, 230V/60Hz, CSIR, fan 3m/s, UL, CB

		Evaporating pressure (saturation temperature)				Cooling capacity			COP	EER	Power consumption				
		Condensing pressure (saturation temperature)									Current consumption		Ref. mass flow		
		Return gas temp.									I		m		
		Liquid temp.													
		Cooling capacity													
		pe	pc	RGT	Tliq	[W]	[Btu/h]	[kcal/h]	[W/W]	[Btu/Wh]	[kcal/Wh]	P1	I	m	
[°C]	[°F]	[°C]	[°F]	[°C]	[°C]							[W]	[A]	[kg/h]	
-7	20	54	130	35	46	1177,6	4022	1013,4	2,02	6,89	1,74	583,8	3,29	13,43	ASHRAE MBP
-10	14	55	131	32	55	942,4	3219	811,1	1,70	5,79	1,46	555,6	3,19	11,92	cecomaf MBP
-10	14	45	113	20	45	1038,2	3546	893,5	2,03	6,93	1,75	511,8	3,03	12,75	EN12900 MBP
-7	20	49	120	18	49	1102,4	3765	948,7	1,98	6,76	1,70	557,2	3,19	14,31	ARI540 MBP
-10	14	45	113	32	45	1080,8	3691	930,2	2,11	7,21	1,82	511,8	3,03	12,36	opt
-25	-13	45	113	32	45	587,5	2006	505,6	1,52	5,21	1,31	385,3	2,57	6,63	opt

Performance tables

R290, 230V/60Hz, CSIR, fan 3m/s, UL, CB

	pe		Cooling capacity			COP	EER	P1			I	m
	[°C]	[°F]	[W]	[Btu/h]	[kcal/h]	[W/W]	[Btu/Wh]	[kcal/Wh]	[W]	[A]	[kg/h]	
[°C / °F]	-25	-13	587,5	2006	505,6	1,52	5,21	1,31	385,3	2,57	6,63	
cond. pressure	-23	-10	633,4	2163	545,2	1,58	5,41	1,36	400,0	2,63	7,15	
pc= 45/113	-15	5	895,1	3057	770,3	1,90	6,48	1,63	471,9	2,88	10,18	
return gas temp.	-9	15	1102,9	3767	949,2	2,14	7,30	1,84	516,0	3,04	12,63	
RGT= 32/90	-4	25	1341,2	4581	1154,3	2,42	8,26	2,08	554,8	3,18	15,47	
liquid temp	0	32	1527,9	5218	1314,9	2,64	9,03	2,28	577,8	3,27	17,72	
Tliq= 45/113	7,2	45	1922,4	6565	1654,4	3,16	10,78	2,72	608,8	3,38	22,59	
[°C / °F]	-25	-13	511,3	1746	440,1	1,26	4,29	1,08	406,6	2,65	6,37	
cond. pressure	-23	-10	551,7	1884	474,8	1,30	4,45	1,12	423,4	2,71	6,88	
pc= 55/131	-15	5	780,5	2666	671,7	1,54	5,25	1,32	507,4	3,01	9,81	
return gas temp	-9	15	961,7	3284	827,6	1,71	5,86	1,48	560,8	3,20	12,17	
RGT= 32/90	-4	25	1169,6	3994	1006,6	1,92	6,55	1,65	610,1	3,38	14,93	
liquid temp	0	32	1332,8	4552	1147,0	2,08	7,10	1,79	641,0	3,49	17,12	
Tliq= 55/131	7,2	45	1678,8	5733	1444,8	2,44	8,33	2,10	688,2	3,66	21,87	

Model

Designation	NLE11MNT	208-230V/60Hz	Conf. 3	Sales code:	105H6199
-------------	-----------------	----------------------	----------------	-------------	-----------------

Configuration

Motorconfiguration	RSCR	
Power supply (nominal)	208-230V/60Hz 1~	
Refrigerant	R290	
Application	MBP	
Voltage range	187-253V	
Starting torque	LST	
Approvals	UL	SA3693
	CB	

Electrical accessories / wiring diagram

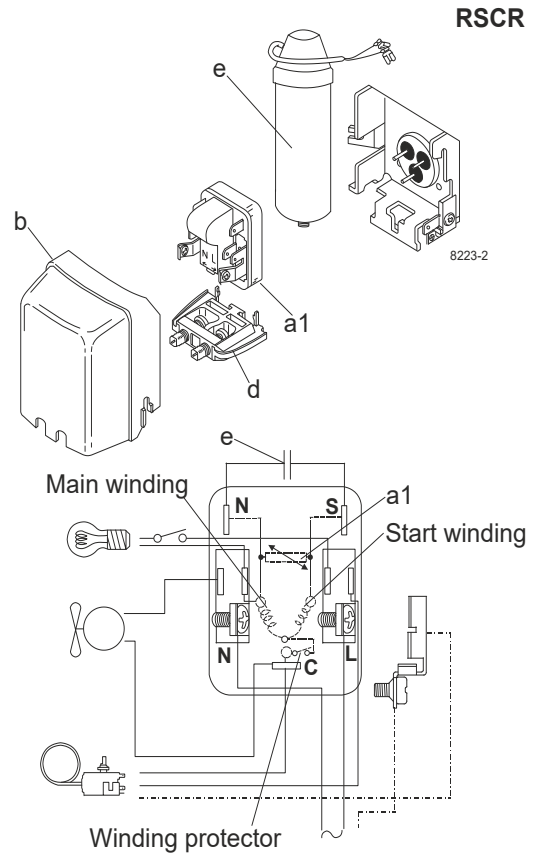

Ambient/ machine room temperatures minimum /maximum

Ambient temperature range:	10 - 43°C / 50 - 110°F
Machine room temperature range:	10 - 48°C / 50 - 119°F
Compressor cooling:	fan 3m/s

Operation pressure range

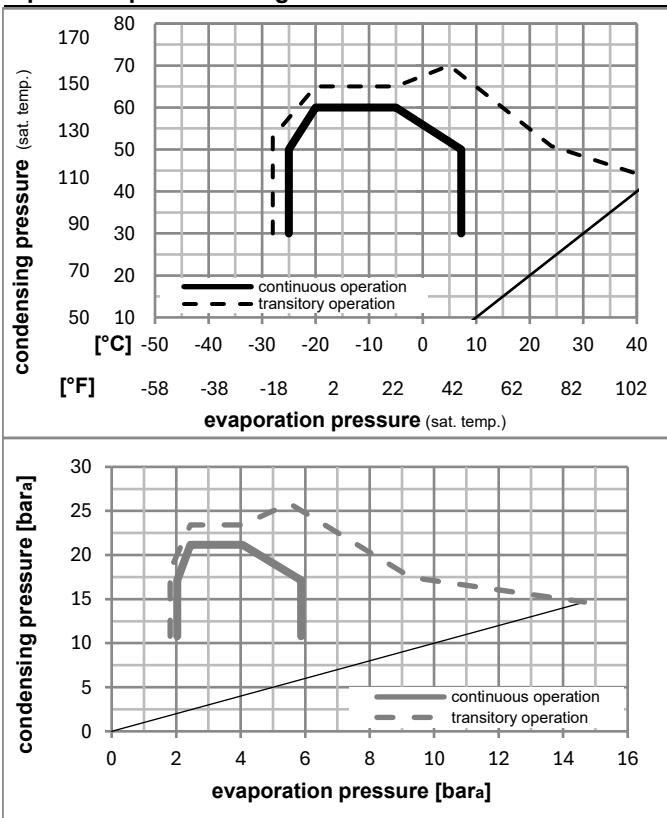

Components

a1	e-PTC starter (220V, 250hm, 4.8mm)	103N0050
e	run capacitor (4μF, 4.8mm)	117-7119
b	plastic cover	103N2011
d	cord relief	103N1010
	bracket for run capacitor	117-0300
	screw M4x8mm	117-0301

Model

Designation **NLE11MNT** **208-230V/60Hz** Conf. 3 Sales code: **105H6199**

Optimization + standard conditions

R290, 230V/60Hz, RSCR, fan 3m/s, UL, CB

		Evaporating pressure (saturation temperature)				Cooling capacity			COP	EER	Power consumption				
		Condensing pressure (saturation temperature)									Current consumption		Ref. mass flow		
		Return gas temp.									I		m		
		Liquid temp.													
		Cooling capacity													
		pe	pc	RGT	Tliq	[W]	[Btu/h]	[kcal/h]	[W/W]	[Btu/Wh]	[kcal/Wh]	P1	I	m	
[°C]	[°F]	[°C]	[°F]	[°C]	[°C]							[W]	[A]	[kg/h]	
-7	20	54	130	35	46	1201,6	4104	1034,1	2,18	7,45	1,88	551,1	2,69	13,71	ASHRAE MBP
-10	14	55	131	32	55	962,4	3287	828,2	1,83	6,26	1,58	525,4	2,59	12,17	cecomaf MBP
-10	14	45	113	20	45	1052,0	3593	905,4	2,17	7,40	1,86	485,7	2,47	12,92	EN12900 MBP
-7	20	49	120	18	49	1120,4	3826	964,2	2,13	7,26	1,83	527,2	2,61	14,55	ARI540 MBP
-10	14	45	113	32	45	1095,2	3740	942,5	2,25	7,70	1,94	485,7	2,47	12,53	opt
-25	-13	45	113	32	45	593,7	2028	511,0	1,61	5,51	1,39	368,2	2,06	6,70	opt

Performance tables

R290, 230V/60Hz, RSCR, fan 3m/s, UL, CB

	pe		Cooling capacity			COP	EER	P1			I	m
	[°C]	[°F]	[W]	[Btu/h]	[kcal/h]	[W/W]	[Btu/Wh]	[kcal/Wh]	[W]	[A]	[kg/h]	
[°C / °F]	-25	-13	593,7	2028	511,0	1,61	5,51	1,39	368,2	2,06	6,70	
cond. pressure	-23	-10	640,6	2188	551,3	1,68	5,73	1,44	382,0	2,11	7,23	
pc= 45/113	-15	5	906,7	3097	780,3	2,02	6,90	1,74	448,8	2,34	10,32	
return gas temp.	-9	15	1117,6	3817	961,8	2,28	7,80	1,96	489,6	2,48	12,79	
RGT= 32/90	-4	25	1359,2	4642	1169,7	2,59	8,84	2,23	525,2	2,62	15,67	
liquid temp	0	32	1548,3	5288	1332,5	2,83	9,68	2,44	546,2	2,69	17,96	
Tliq= 45/113	7,2	45	1947,6	6651	1676,1	3,39	11,58	2,92	574,5	2,80	22,88	
[°C / °F]	-25	-13	520,3	1777	447,7	1,34	4,59	1,16	387,3	2,09	6,48	
cond. pressure	-23	-10	562,0	1919	483,7	1,39	4,76	1,20	403,1	2,15	7,01	
pc= 55/131	-15	5	797,0	2722	685,9	1,66	5,66	1,43	480,9	2,43	10,02	
return gas temp	-9	15	982,0	3354	845,1	1,85	6,33	1,59	530,1	2,61	12,43	
RGT= 32/90	-4	25	1193,4	4076	1027,1	2,08	7,09	1,79	575,1	2,79	15,23	
liquid temp	0	32	1358,9	4641	1169,5	2,25	7,69	1,94	603,2	2,90	17,45	
Tliq= 55/131	7,2	45	1709,0	5837	1470,8	2,65	9,04	2,28	645,7	3,07	22,27	

Model

Designation	NLE11MNT	208-230V/60Hz	Conf. 4	Sales code:	105H6199
-------------	-----------------	----------------------	----------------	-------------	-----------------

Configuration

Motorconfiguration	RSIR	
Power supply (nominal)	208-230V/60Hz 1~	
Refrigerant	R290	
Application	MBP	
Voltage range	187-253V	
Starting torque	LST	
Approvals	UL	SA3693
	CB	

Electrical accessories / wiring diagram

RSIR

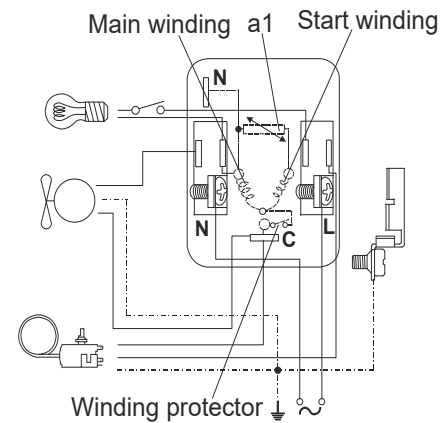
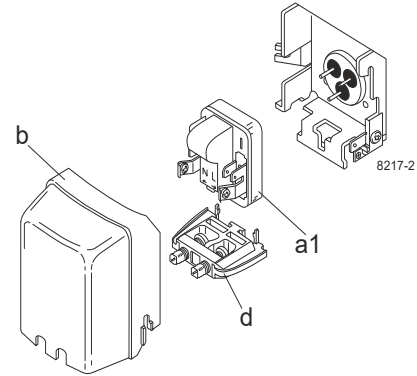

Ambient/ machine room temperatures minimum /maximum

Ambient temperature range:	10 - 43°C / 50 - 110°F
Machine room temperature range:	10 - 48°C / 50 - 119°F
Compressor cooling:	fan 3m/s

Operation pressure range

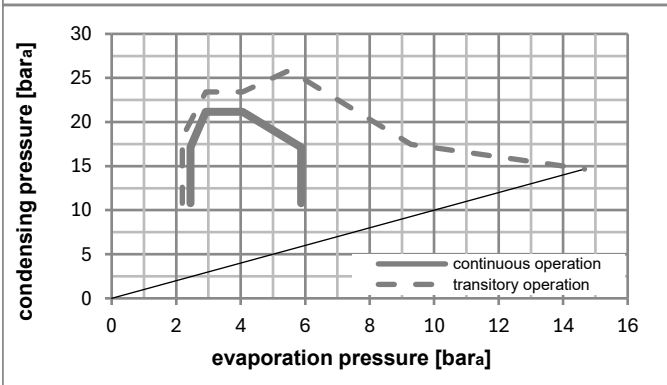
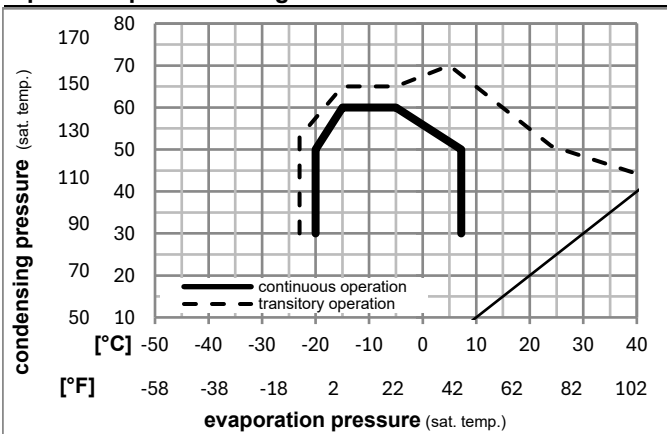

Components

a1	e-PTC starter (220V, 25Ohm, 4.8mm)	103N0050
b	plastic cover	103N2011
d	cord relief	103N1010

Model

Designation **NLE11MNT** **208-230V/60Hz** Conf. 4 Sales code: **105H6199**

Optimization + standard conditions

R290, 230V/60Hz, RSIR, fan 3m/s, UL, CB

		Evaporating pressure (saturation temperature)				Cooling capacity			COP	EER	Power consumption				
		Condensing pressure (saturation temperature)									Current consumption		Ref. mass flow		
		Return gas temp.													
		Liquid temp.													
		Cooling capacity													
		pe	pc	RGT	Tliq	[W]	[Btu/h]	[kcal/h]	[W/W]	[Btu/Wh]	[kcal/Wh]	P1	I	m	
[°C]	[°F]	[°C]	[°F]	[°C]	[°C]							[W]	[A]	[kg/h]	
-7	20	54	130	35	46	1177,6	4022	1013,4	2,02	6,89	1,74	583,8	3,29	13,43	ASHRAE MBP
-10	14	55	131	32	55	942,4	3219	811,1	1,70	5,79	1,46	555,6	3,19	11,92	cecomaf MBP
-10	14	45	113	20	45	1038,2	3546	893,5	2,03	6,93	1,75	511,8	3,03	12,75	EN12900 MBP
-7	20	49	120	18	49	1102,4	3765	948,7	1,98	6,76	1,70	557,2	3,19	14,31	ARI540 MBP
-10	14	45	113	32	45	1080,8	3691	930,2	2,11	7,21	1,82	511,8	3,03	12,36	opt
-25	-13	45	113	32	45	587,5	2006	505,6	1,52	5,21	1,31	385,3	2,57	6,63	opt

Performance tables

R290, 230V/60Hz, RSIR, fan 3m/s, UL, CB

	pe		Cooling capacity			COP	EER	P1			I	m
	[°C]	[°F]	[W]	[Btu/h]	[kcal/h]	[W/W]	[Btu/Wh]	[kcal/Wh]	[W]	[A]	[kg/h]	
[°C / °F]	-20	-4	731,5	2498	629,5	1,70	5,82	1,47	429,3	2,73	8,28	
cond. pressure	-15	5	895,1	3057	770,3	1,90	6,48	1,63	471,9	2,88	10,18	
pc= 45/113	-9	15	1102,9	3767	949,2	2,14	7,30	1,84	516,0	3,04	12,63	
return gas temp.	-7	20	1218,1	4160	1048,3	2,27	7,76	1,96	536,2	3,12	13,99	
RGT= 32/90	-4	25	1341,2	4581	1154,3	2,42	8,26	2,08	554,8	3,18	15,47	
liquid temp	0	32	1527,9	5218	1314,9	2,64	9,03	2,28	577,8	3,27	17,72	
Tliq= 45/113	7,2	45	1922,4	6565	1654,4	3,16	10,78	2,72	608,8	3,38	22,59	
[°C / °F]	-20	-4	637,6	2178	548,7	1,39	4,76	1,20	457,2	2,83	7,97	
cond. pressure	-15	5	780,5	2666	671,7	1,54	5,25	1,32	507,4	3,01	9,81	
pc= 55/131	-9	15	961,7	3284	827,6	1,71	5,86	1,48	560,8	3,20	12,17	
return gas temp	-7	20	1062,1	3627	914,1	1,81	6,19	1,56	586,1	3,30	13,50	
RGT= 32/90	-4	25	1169,6	3994	1006,6	1,92	6,55	1,65	610,1	3,38	14,93	
liquid temp	0	32	1332,8	4552	1147,0	2,08	7,10	1,79	641,0	3,49	17,12	
Tliq= 55/131	7,2	45	1678,8	5733	1444,8	2,44	8,33	2,10	688,2	3,66	21,87	

Model

Designation	NLE11MNT	208-230V/60Hz	Conf. 5	Sales code:	105H6199
-------------	-----------------	----------------------	----------------	-------------	-----------------

Configuration

Motorconfiguration	RSIR	
Power supply (nominal)	208-230V/60Hz 1~	
Refrigerant	R290	
Application	MBP	
Voltage range	187-242V	
Starting torque	LST	
Approvals	UL	SA3693
	CB	

Electrical accessories / wiring diagram

RSIR

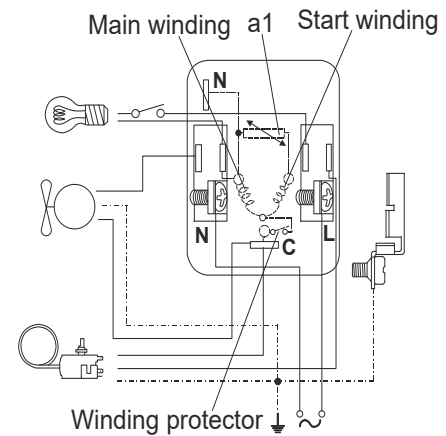
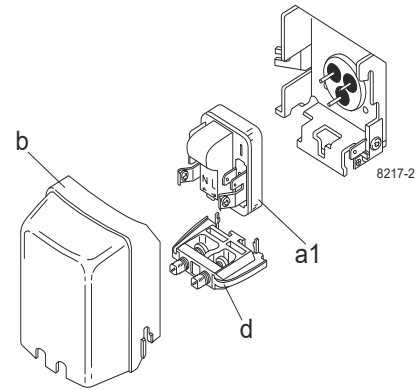

Ambient/ machine room temperatures minimum /maximum

Ambient temperature range:	10 - 43°C / 50 - 110°F
Machine room temperature range:	10 - 48°C / 50 - 119°F
Compressor cooling:	fan 3m/s

Operation pressure range

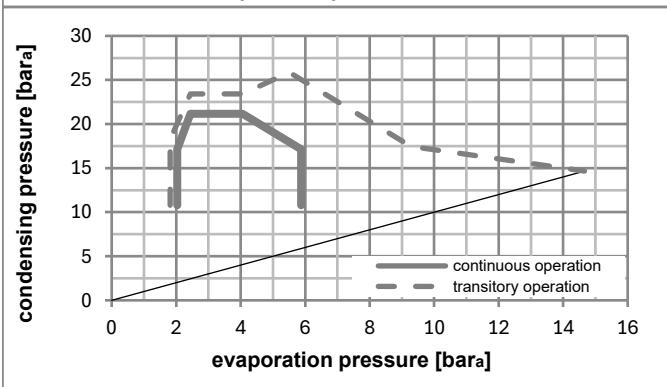
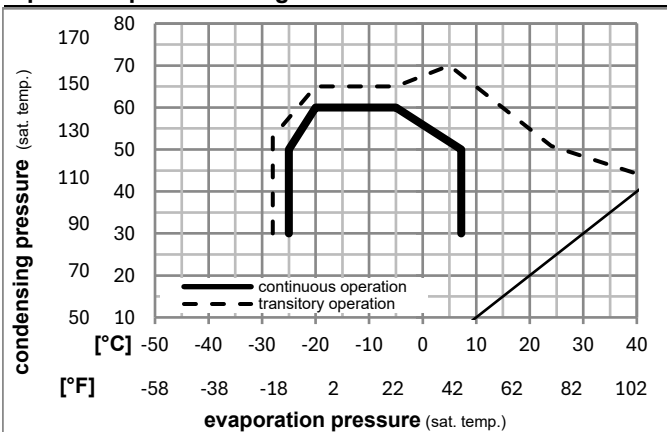

Components

a1	e-PTC starter (220V, 25Ohm, 4.8mm)	103N0050
b	plastic cover	103N2011
d	cord relief	103N1010

Model

Designation **NLE11MNT** **208-230V/60Hz** Conf. 5 Sales code: **105H6199**

Optimization + standard conditions

R290, 230V/60Hz, RSIR, fan 3m/s, UL, CB

		Evaporating pressure (saturation temperature)				Cooling capacity			COP	EER	Power consumption				
		Condensing pressure (saturation temperature)									Current consumption		Ref. mass flow		
		Return gas temp.													
		Liquid temp.													
		Cooling capacity													
		pe	pc	RGT	Tliq	[W]	[Btu/h]	[kcal/h]	[W/W]	[Btu/Wh]	[kcal/Wh]	P1	I	m	
[°C]	[°F]	[°C]	[°F]	[°C]	[°C]							[W]	[A]	[kg/h]	
-7	20	54	130	35	46	1177,6	4022	1013,4	2,02	6,89	1,74	583,8	3,29	13,43	ASHRAE MBP
-10	14	55	131	32	55	942,4	3219	811,1	1,70	5,79	1,46	555,6	3,19	11,92	cecomaf MBP
-10	14	45	113	20	45	1038,2	3546	893,5	2,03	6,93	1,75	511,8	3,03	12,75	EN12900 MBP
-7	20	49	120	18	49	1102,4	3765	948,7	1,98	6,76	1,70	557,2	3,19	14,31	ARI540 MBP
-10	14	45	113	32	45	1080,8	3691	930,2	2,11	7,21	1,82	511,8	3,03	12,36	opt
-25	-13	45	113	32	45	587,5	2006	505,6	1,52	5,21	1,31	385,3	2,57	6,63	opt

Performance tables

R290, 230V/60Hz, RSIR, fan 3m/s, UL, CB

	pe		Cooling capacity			COP	EER	P1			I	m
	[°C]	[°F]	[W]	[Btu/h]	[kcal/h]	[W/W]	[Btu/Wh]	[kcal/Wh]	[W]	[A]	[kg/h]	
[°C / °F]	-25	-13	587,5	2006	505,6	1,52	5,21	1,31	385,3	2,57	6,63	
cond. pressure	-23	-10	633,4	2163	545,2	1,58	5,41	1,36	400,0	2,63	7,15	
pc= 45/113	-15	5	895,1	3057	770,3	1,90	6,48	1,63	471,9	2,88	10,18	
return gas temp.	-9	15	1102,9	3767	949,2	2,14	7,30	1,84	516,0	3,04	12,63	
RGT= 32/90	-4	25	1341,2	4581	1154,3	2,42	8,26	2,08	554,8	3,18	15,47	
liquid temp	0	32	1527,9	5218	1314,9	2,64	9,03	2,28	577,8	3,27	17,72	
Tliq= 45/113	7,2	45	1922,4	6565	1654,4	3,16	10,78	2,72	608,8	3,38	22,59	
[°C / °F]	-25	-13	511,3	1746	440,1	1,26	4,29	1,08	406,6	2,65	6,37	
cond. pressure	-23	-10	551,7	1884	474,8	1,30	4,45	1,12	423,4	2,71	6,88	
pc= 55/131	-15	5	780,5	2666	671,7	1,54	5,25	1,32	507,4	3,01	9,81	
return gas temp	-9	15	961,7	3284	827,6	1,71	5,86	1,48	560,8	3,20	12,17	
RGT= 32/90	-4	25	1169,6	3994	1006,6	1,92	6,55	1,65	610,1	3,38	14,93	
liquid temp	0	32	1332,8	4552	1147,0	2,08	7,10	1,79	641,0	3,49	17,12	
Tliq= 55/131	7,2	45	1678,8	5733	1444,8	2,44	8,33	2,10	688,2	3,66	21,87	