

Model

| | | | | |
|-------------|------------------|------------------|-------------|-----------------|
| Designation | NLE12.6MN | 220-240V/50Hz 1~ | Sales code: | 105H6383 |
|-------------|------------------|------------------|-------------|-----------------|

Compressor design

| | | | |
|----------------------------|---------------------------------|-----------------------|----------------------------------|
| Oil type | Polyolester | Refrigerant(s) | R290 |
| Oil viscosity | 32cST | Displacement | 12,55cm ³ / 0,77cu.in |
| Oil quantity | 298cm ³ / 10,1fl.oz | Compressors on pallet | 80 |
| Refr. charge - tech. limit | 300g / 10,6oz | | |
| Free gas volume comp. | 2360cm ³ / 79,8fl.oz | | |
| Weight | 12,1kg / 26,7lbs | | |
| Motor protection | 1# internal | | |
| Winding resistance main | 5Ω (at 25°C) | | |
| Winding resistance aux | 9,9Ω (at 25°C) | | |
| Max. winding temp. | 125°C / 257°F | | |
| Max. discharge temp. | 130°C / 266°F | | |



General - Configurations with NLE12.6MN

| | Conf. 1 | Conf. 2 | Conf. 3 |
|------------------------|----------------|----------------|----------------|
| Motorconfiguration | CSIR | eRSIR | eRSCR |
| Power supply (nominal) | 220-240V/50Hz | 220-240V/50Hz | 220-240V/50Hz |
| Number of phases | 1 | 1 | 1 |
| Voltage range | 198-254V | 198-254V | 198-254V |
| Approvals | VDE, CCC, EAC | VDE, CCC, EAC | VDE, CCC, EAC |
| Starting torque | HST | LST | LST |
| Note | - / - | | |

Applications with NLE12.6MN

| | Conf. 1 | Conf. 2 | Conf. 3 |
|-------------------------|----------------|----------------|----------------|
| Refrigerant | R290 | R290 | R290 |
| Application | MBP | MBP | MBP |
| System cooling | fan 3m/s | fan 3m/s | fan 3m/s |
| Hot gas defrost | OK | OK | OK |
| Long interval pull down | OK | OK | OK |

Electrical data - Configurations with NLE12.6MN

| | Conf. 1 | Conf. 2 | Conf. 3 |
|------------------------------------|----------------|----------------|----------------|
| Starting device type | relay | e-PTC | e-PTC |
| Run capacitor | -/- | -/- | 4μF |
| Start capacitor | 80μF | -/- | -/- |
| LRA (locked rotor amps / 4s/ U(N)) | 15,6A | 16A | 16A |
| RLA (rated load amps / 1s/ U(N)) | 2,7A | 2,7A | 2,7A |
| Cut in current (U(N)) | 21,2A | 21,2A | 21,2A |

Model

| | | | | |
|-------------|------------------|------------------|-------------|-----------------|
| Designation | NLE12.6MN | 220-240V/50Hz 1~ | Sales code: | 105H6383 |
|-------------|------------------|------------------|-------------|-----------------|

Compressor dimensions

| | | |
|----------------|-------------------|----------------|
| Housing | A Height | 203mm / 7,99in |
| | B Height | 197mm / 7,76in |
| | C Length shell | 205mm / 8,07in |
| | D Length w. cover | 254mm / 10in |
| | E Width | 166mm / 6,54in |

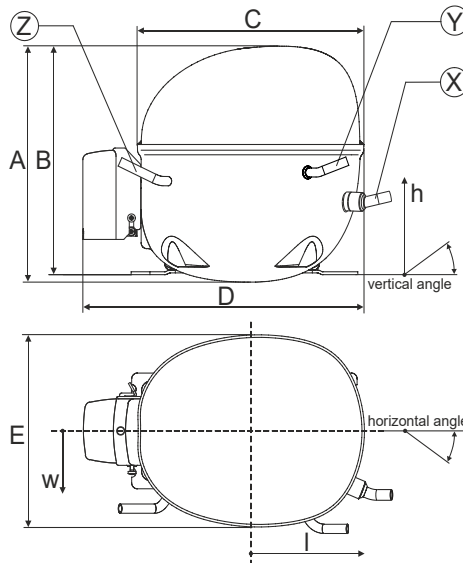

| Connectors | | Suction | Discharge | Process |
|------------------|----------------------------|--------------|--------------|--------------|
| | | X | Y | Z |
| Diameter | [mm] | øi 8,11-8,29 | øi 6,41-6,59 | øi 6,41-6,59 |
| | (i:inside, o:outside) [in] | øi 0,32-0,33 | øi 0,25-0,26 | øi 0,25-0,26 |
| Material | | copper | copper | copper |
| Horizontal angle | ±2° | 0° | 0° | 0° |
| Vertical angle | ±2° | 15° | 21° | 155° |
| Position l/h/w | [mm] | 132/69/57 | 94/102/81 | -109/94/72 |
| | [in] | 5,2/2,7/2,2 | 3,7/4/3,2 | -4,3/3,7/2,8 |
| Straight tube l. | [mm] | 12 | 12 | 12 |
| | [in] | 0,5 | 0,5 | 0,5 |

Compressor fixation

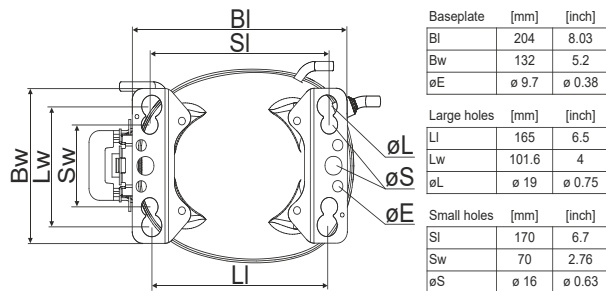

Bolt joint

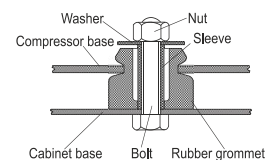

Snap-on

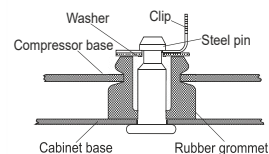

| Mounting accessories | one comp. | multi pack |
|----------------------------|-----------|------------|
| Bolt joint M6 ø16mm | 118-1917 | 118-1918 |
| Bolt joint ø1/4" ø16mm | 118-1946 | |
| Bolt joint ø1/4" ø19mm | 118-1949 | |
| Snap-on ø7,3 ø16mm | 118-1947 | 118-1919 |

Application notes

Provision for PE Grounding is located at the PE Stamp on the compressor

Model

| | | | | | |
|-------------|------------------|----------------------|----------------|-------------|-----------------|
| Designation | NLE12.6MN | 220-240V/50Hz | Conf. 1 | Sales code: | 105H6383 |
|-------------|------------------|----------------------|----------------|-------------|-----------------|

Configuration

| | |
|------------------------|------------------|
| Motorconfiguration | CSIR |
| Power supply (nominal) | 220-240V/50Hz 1~ |
| Refrigerant | R290 |
| Application | MBP |
| Voltage range | 198-254V |
| Starting torque | HST |
| Approvals | VDE |
| | CCC |
| | EAC |

Electrical accessories / wiring diagram

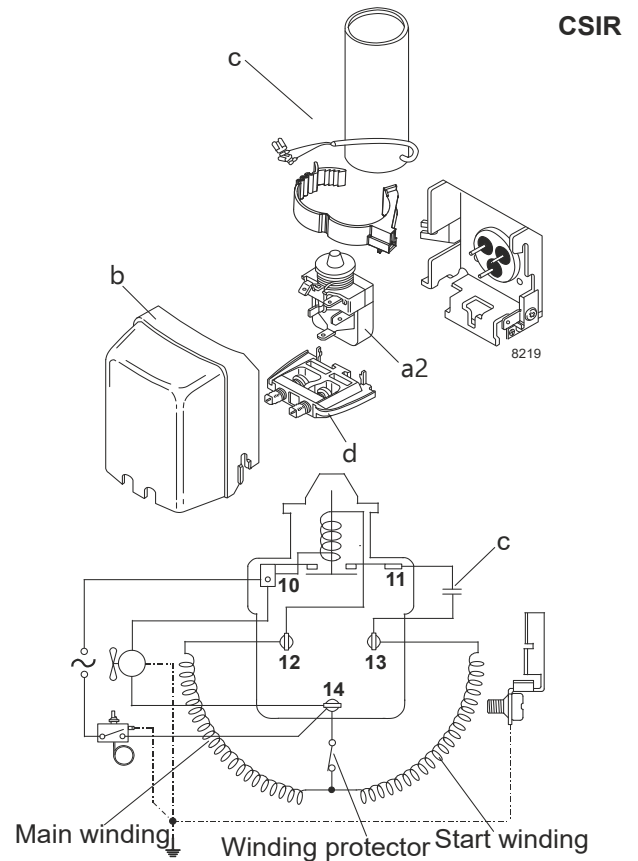

Ambient/ machine room temperatures minimum /maximum

| | |
|---------------------------------|------------------------|
| Ambient temperature range: | 10 - 43°C / 50 - 110°F |
| Machine room temperature range: | 10 - 48°C / 50 - 119°F |
| Compressor cooling: | fan 3m/s |

Operation pressure range

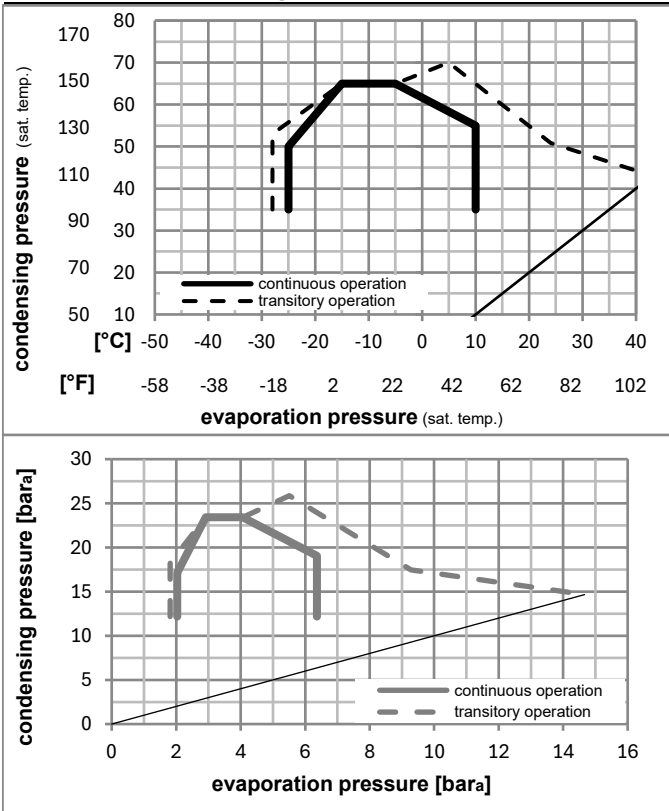

Components

| | | |
|----|------------------------|----------|
| a2 | relay | 117U7011 |
| c | start capacitor (80µF) | 117U5015 |
| b | plastic cover | 103N2010 |
| d | cord relief | 103N1010 |

Alternative components

| | | |
|---|---------------|----------|
| b | plastic cover | 103N2011 |
|---|---------------|----------|

Model

Designation **NLE12.6MN** **220-240V/50Hz** Conf. 1 Sales code: **105H6383**

Optimization + standard conditions

R290, 220V/50Hz, CSIR, fan 3m/s, VDE, CCC, EAC

| | | Evaporating pressure (saturation temperature) | | | | Condensing pressure (saturation temperature) | | | Return gas temp. | | Liquid temp. | | Cooling capacity | | | COP | EER | Power consumption | | |
|------|------|---|-----|-----|------|--|---------|----------|------------------|----------|--------------|-------|------------------|----------------|--|--------------------|-----|-------------------|--|--|
| | | pe | pc | RGT | Tliq | [W] | [Btu/h] | [kcal/h] | [W/W] | [Btu/Wh] | [kcal/Wh] | P1 | I | Ref. mass flow | | | | | | |
| [°C] | [°F] | | | | | | | | | | | [W] | [A] | [kg/h] | | | | | | |
| | | -7 | 54 | 35 | 46 | 1060,9 | 3623 | 913,0 | 1,97 | 6,74 | 1,70 | 537,5 | 3,10 | 12,10 | | ASHRAE MBP | | | | |
| | | 20 | 130 | 95 | 115 | | | | | | | | | | | | | | | |
| | | -10 | 55 | 32 | 55 | 842,6 | 2878 | 725,2 | 1,66 | 5,67 | 1,43 | 507,7 | 2,99 | 10,66 | | cecomaf MBP | | | | |
| | | 14 | 131 | 90 | 131 | | | | | | | | | | | | | | | |
| | | -10 | 45 | 20 | 45 | 949,0 | 3241 | 816,7 | 2,05 | 7,01 | 1,77 | 462,3 | 2,77 | 11,65 | | EN12900 MBP | | | | |
| | | 14 | 113 | 68 | 113 | | | | | | | | | | | | | | | |
| | | -7 | 49 | 18 | 49 | 1004,0 | 3429 | 864,0 | 1,98 | 6,76 | 1,70 | 506,9 | 2,95 | 13,04 | | ARI540 MBP | | | | |
| | | 20 | 120 | 65 | 120 | | | | | | | | | | | | | | | |
| | | -10 | 45 | 32 | 45 | 987,9 | 3374 | 850,2 | 2,14 | 7,30 | 1,84 | 462,3 | 2,77 | 11,30 | | opt | | | | |
| | | 14 | 113 | 90 | 113 | | | | | | | | | | | | | | | |
| | | -25 | 45 | 32 | 45 | 536,2 | 1831 | 461,5 | 1,53 | 5,21 | 1,31 | 351,5 | 2,41 | 6,05 | | opt | | | | |
| | | -13 | 113 | 90 | 113 | | | | | | | | | | | | | | | |

Performance tables

R290, 220V/50Hz, CSIR, fan 3m/s, VDE, CCC, EAC

| | pe | | Cooling capacity | | | COP | EER | P1 | I | m | |
|------------------|------|------|------------------|---------|----------|-------|----------|-----------|-------|------|--------|
| | [°C] | [°F] | [W] | [Btu/h] | [kcal/h] | [W/W] | [Btu/Wh] | [kcal/Wh] | [W] | [A] | [kg/h] |
| [°C / °F] | -25 | -13 | 536,2 | 1831 | 461,5 | 1,53 | 5,21 | 1,31 | 351,5 | 2,41 | 6,05 |
| cond. pressure | -20 | -4 | 663,0 | 2264 | 570,5 | 1,71 | 5,84 | 1,47 | 387,9 | 2,52 | 7,51 |
| pc= 45/113 | -15 | 5 | 813,0 | 2776 | 699,6 | 1,91 | 6,53 | 1,65 | 425,1 | 2,65 | 9,25 |
| return gas temp. | -10 | 14 | 987,9 | 3374 | 850,2 | 2,14 | 7,30 | 1,84 | 462,3 | 2,77 | 11,30 |
| RGT= 32/90 | 0 | 32 | 1419,6 | 4848 | 1221,7 | 2,66 | 9,07 | 2,29 | 534,6 | 3,06 | 16,47 |
| liquid temp | 5 | 41 | 1679,8 | 5737 | 1445,6 | 2,96 | 10,09 | 2,54 | 568,4 | 3,22 | 19,65 |
| Tliq= 45/113 | 10 | 50 | 1971,8 | 6734 | 1696,9 | 3,29 | 11,23 | 2,83 | 599,9 | 3,39 | 23,30 |
| [°C / °F] | -25 | -13 | 451,6 | 1542 | 388,7 | 1,21 | 4,14 | 1,04 | 372,6 | 2,49 | 5,62 |
| cond. pressure | -20 | -4 | 561,6 | 1918 | 483,4 | 1,35 | 4,62 | 1,17 | 414,9 | 2,64 | 7,02 |
| pc= 55/131 | -15 | 5 | 691,4 | 2361 | 595,0 | 1,50 | 5,13 | 1,29 | 460,1 | 2,81 | 8,69 |
| return gas temp | -10 | 14 | 842,6 | 2878 | 725,2 | 1,66 | 5,67 | 1,43 | 507,7 | 2,99 | 10,66 |
| RGT= 32/90 | 0 | 32 | 1216,3 | 4154 | 1046,8 | 2,00 | 6,84 | 1,72 | 607,6 | 3,39 | 15,62 |
| liquid temp | 5 | 41 | 1442,2 | 4925 | 1241,2 | 2,19 | 7,48 | 1,88 | 658,7 | 3,61 | 18,70 |
| Tliq= 55/131 | 10 | 50 | 1696,5 | 5794 | 1460,0 | 2,39 | 8,16 | 2,06 | 709,7 | 3,85 | 22,24 |

Model

| | | | | | |
|-------------|------------------|----------------------|----------------|-------------|-----------------|
| Designation | NLE12.6MN | 220-240V/50Hz | Conf. 2 | Sales code: | 105H6383 |
|-------------|------------------|----------------------|----------------|-------------|-----------------|

Configuration

| | |
|------------------------|------------------|
| Motor configuration | eRSIR |
| Power supply (nominal) | 220-240V/50Hz 1~ |
| Refrigerant | R290 |
| Application | MBP |
| Voltage range | 198-254V |
| Starting torque | LST |
| Approvals | VDE |
| | CCC |
| | EAC |

Electrical accessories / wiring diagram

RSIR

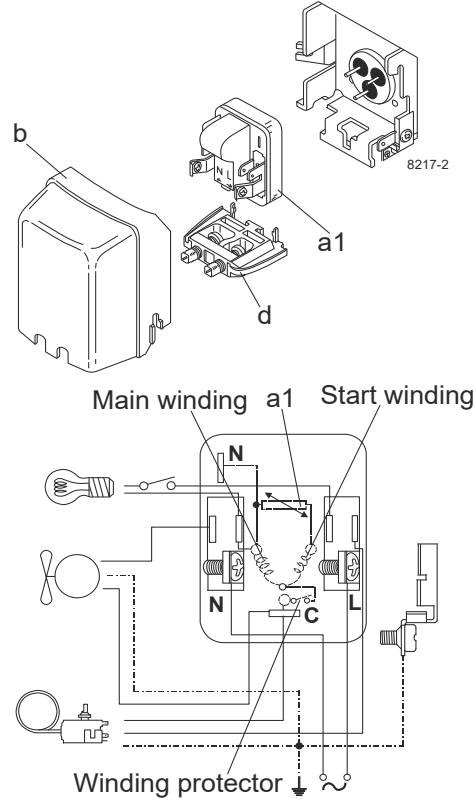

Ambient/ machine room temperatures minimum /maximum

| | |
|---------------------------------|------------------------|
| Ambient temperature range: | 10 - 43°C / 50 - 110°F |
| Machine room temperature range: | 10 - 48°C / 50 - 119°F |
| Compressor cooling: | fan 3m/s |

Operation pressure range

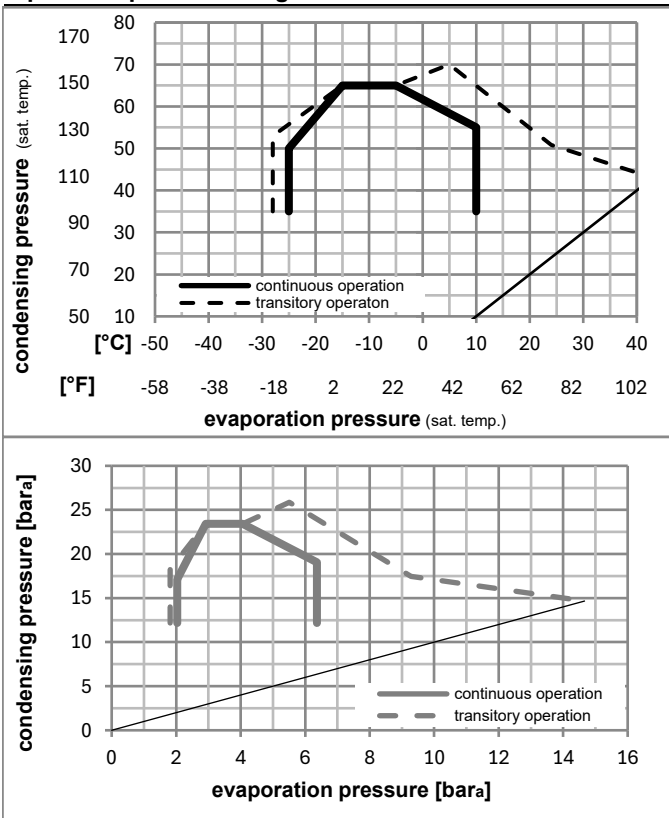

Components

| | | |
|----|------------------------------------|----------|
| a1 | e-PTC starter (220V, 250hm, 4.8mm) | 103N0050 |
| b | plastic cover | 103N2010 |
| d | cord relief | 103N1010 |

Alternative components

| | | |
|---|---------------|----------|
| b | plastic cover | 103N2011 |
|---|---------------|----------|

Model

Designation **NLE12.6MN** **220-240V/50Hz** Conf. 2 Sales code: **105H6383**

Optimization + standard conditions

R290, 220V/50Hz, eRSIR, fan 3m/s, VDE, CCC, EAC

| | Evaporating pressure (saturation temperature) | | | | Cooling capacity | | | COP | EER | P1 | Power consumption | | Ref. mass flow | | | | | |
|--|---|------|------|------|------------------|---------|----------|-------|----------|-----------|-------------------|------|----------------|------|-------|------|-------|-------------|
| | pe | pc | RGT | Tliq | [W] | [Btu/h] | [kcal/h] | | | | I | m | | | | | | |
| | [°C] | [°F] | [°C] | [°F] | [W] | [Btu/h] | [kcal/h] | [W/W] | [Btu/Wh] | [kcal/Wh] | [W] | [A] | [kg/h] | | | | | |
| | -7 | 20 | 54 | 130 | 35 | 95 | 46 | 115 | 1060,9 | 3623 | 913,0 | 1,97 | 6,74 | 1,70 | 537,5 | 3,10 | 12,10 | ASHRAE MBP |
| | -10 | 14 | 55 | 131 | 32 | 90 | 55 | 131 | 842,6 | 2878 | 725,2 | 1,66 | 5,67 | 1,43 | 507,7 | 2,99 | 10,66 | cecomaf MBP |
| | -10 | 14 | 45 | 113 | 20 | 68 | 45 | 113 | 949,0 | 3241 | 816,7 | 2,05 | 7,01 | 1,77 | 462,3 | 2,77 | 11,65 | EN12900 MBP |
| | -7 | 20 | 49 | 120 | 18 | 65 | 49 | 120 | 1004,0 | 3429 | 864,0 | 1,98 | 6,76 | 1,70 | 506,9 | 2,95 | 13,04 | ARI540 MBP |
| | -10 | 14 | 45 | 113 | 32 | 90 | 45 | 113 | 987,9 | 3374 | 850,2 | 2,14 | 7,30 | 1,84 | 462,3 | 2,77 | 11,30 | opt |
| | -25 | -13 | 45 | 113 | 32 | 90 | 45 | 113 | 536,2 | 1831 | 461,5 | 1,53 | 5,21 | 1,31 | 351,5 | 2,41 | 6,05 | opt |

Performance tables

R290, 220V/50Hz, eRSIR, fan 3m/s, VDE, CCC, EAC

| | pe | | Cooling capacity | | | COP | EER | P1 | I | m | |
|------------------|------|------|------------------|---------|----------|------|-------|------|-------|------|-------|
| | [°C] | [°F] | [W] | [Btu/h] | [kcal/h] | | | | | | |
| [°C / °F] | -25 | -13 | 536,2 | 1831 | 461,5 | 1,53 | 5,21 | 1,31 | 351,5 | 2,41 | 6,05 |
| cond. pressure | -20 | -4 | 663,0 | 2264 | 570,5 | 1,71 | 5,84 | 1,47 | 387,9 | 2,52 | 7,51 |
| pc= 45/113 | -15 | 5 | 813,0 | 2776 | 699,6 | 1,91 | 6,53 | 1,65 | 425,1 | 2,65 | 9,25 |
| return gas temp. | -10 | 14 | 987,9 | 3374 | 850,2 | 2,14 | 7,30 | 1,84 | 462,3 | 2,77 | 11,30 |
| RGT= 32/90 | 0 | 32 | 1419,6 | 4848 | 1221,7 | 2,66 | 9,07 | 2,29 | 534,6 | 3,06 | 16,47 |
| liquid temp | 5 | 41 | 1679,8 | 5737 | 1445,6 | 2,96 | 10,09 | 2,54 | 568,4 | 3,22 | 19,65 |
| Tliq= 45/113 | 10 | 50 | 1971,8 | 6734 | 1696,9 | 3,29 | 11,23 | 2,83 | 599,9 | 3,39 | 23,30 |
| [°C / °F] | -25 | -13 | 451,6 | 1542 | 388,7 | 1,21 | 4,14 | 1,04 | 372,6 | 2,49 | 5,62 |
| cond. pressure | -20 | -4 | 561,6 | 1918 | 483,4 | 1,35 | 4,62 | 1,17 | 414,9 | 2,64 | 7,02 |
| pc= 55/131 | -15 | 5 | 691,4 | 2361 | 595,0 | 1,50 | 5,13 | 1,29 | 460,1 | 2,81 | 8,69 |
| return gas temp | -10 | 14 | 842,6 | 2878 | 725,2 | 1,66 | 5,67 | 1,43 | 507,7 | 2,99 | 10,66 |
| RGT= 32/90 | 0 | 32 | 1216,3 | 4154 | 1046,8 | 2,00 | 6,84 | 1,72 | 607,6 | 3,39 | 15,62 |
| liquid temp | 5 | 41 | 1442,2 | 4925 | 1241,2 | 2,19 | 7,48 | 1,88 | 658,7 | 3,61 | 18,70 |
| Tliq= 55/131 | 10 | 50 | 1696,5 | 5794 | 1460,0 | 2,39 | 8,16 | 2,06 | 709,7 | 3,85 | 22,24 |

Model

| | | | | | |
|-------------|------------------|----------------------|----------------|-------------|-----------------|
| Designation | NLE12.6MN | 220-240V/50Hz | Conf. 3 | Sales code: | 105H6383 |
|-------------|------------------|----------------------|----------------|-------------|-----------------|

Configuration

| | |
|------------------------|------------------|
| Motor configuration | eRSCR |
| Power supply (nominal) | 220-240V/50Hz 1~ |
| Refrigerant | R290 |
| Application | MBP |
| Voltage range | 198-254V |
| Starting torque | LST |
| Approvals | VDE |
| | CCC |
| | EAC |

Electrical accessories / wiring diagram

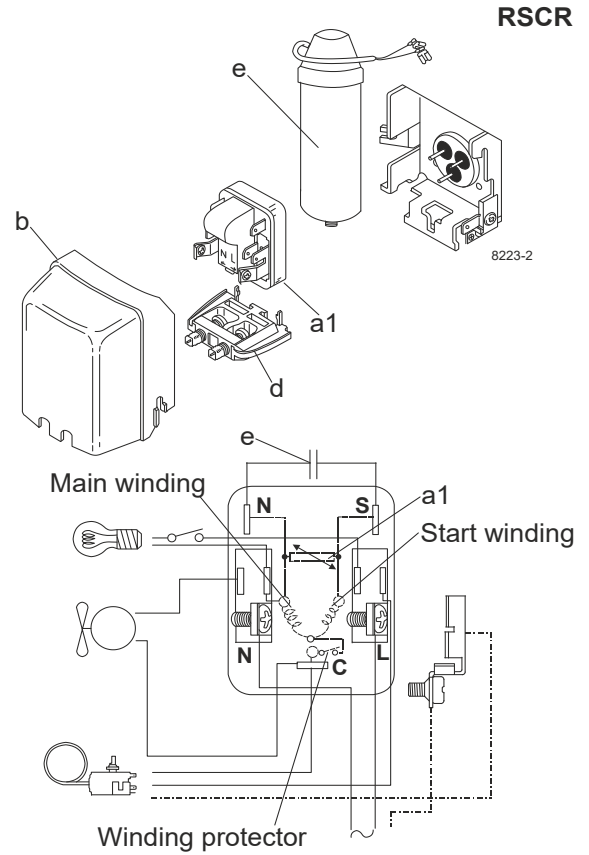

Ambient/ machine room temperatures minimum /maximum

| | |
|---------------------------------|------------------------|
| Ambient temperature range: | 10 - 43°C / 50 - 110°F |
| Machine room temperature range: | 10 - 48°C / 50 - 119°F |
| Compressor cooling: | fan 3m/s |

Operation pressure range

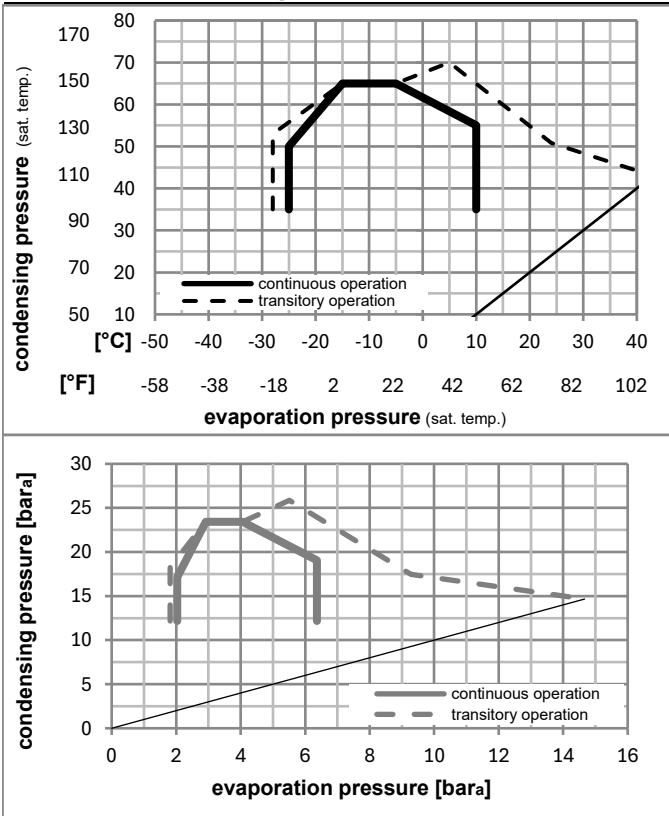

Components

| | | |
|----|------------------------------------|----------|
| a1 | e-PTC starter (220V, 250hm, 4.8mm) | 103N0050 |
| e | run capacitor (4μF, 4.8mm) | 117-7119 |
| b | plastic cover | 103N2010 |
| d | cord relief | 103N1010 |
| | bracket for run capacitor | 117-0300 |
| | screw M4x8mm | 117-0301 |

Alternative components

| | | |
|---|---------------|----------|
| b | plastic cover | 103N2011 |
|---|---------------|----------|

Model

Designation **NLE12.6MN** **220-240V/50Hz** Conf. **3** Sales code: **105H6383**

Optimization + standard conditions

R290, 220V/50Hz, eRSCR, fan 3m/s, VDE, CCC, EAC

| | Evaporating pressure (saturation temperature) | | | | Cooling capacity | | | COP | EER | | | Power consumption | | | ASHRAE MBP |
|------|---|-----|-----|------|------------------|---------|----------|------|-------|----------|-----------|-------------------|-------|-------------|------------|
| | pe | pc | RGT | Tliq | [W] | [Btu/h] | [kcal/h] | | [W/W] | [Btu/Wh] | [kcal/Wh] | P1 | I | m | |
| [°C] | -7 | 54 | 35 | 46 | 1070,3 | 3655 | 921,1 | 2,08 | 7,12 | 1,79 | 513,5 | 2,78 | 12,21 | | |
| [°F] | 20 | 130 | 95 | 115 | | | | | | | | | | | |
| [°C] | -10 | 55 | 32 | 55 | 849,7 | 2902 | 731,3 | 1,75 | 5,97 | 1,51 | 485,8 | 2,67 | 10,75 | cecomaf MBP | |
| [°F] | 14 | 131 | 90 | 131 | | | | | | | | | | | |
| [°C] | -10 | 45 | 20 | 45 | 956,9 | 3268 | 823,5 | 2,16 | 7,39 | 1,86 | 442,5 | 2,49 | 11,75 | EN12900 MBP | |
| [°F] | 14 | 113 | 68 | 113 | | | | | | | | | | | |
| [°C] | -7 | 49 | 18 | 49 | 1012,9 | 3459 | 871,7 | 2,09 | 7,14 | 1,80 | 484,2 | 2,65 | 13,15 | ARI540 MBP | |
| [°F] | 20 | 120 | 65 | 120 | | | | | | | | | | | |
| [°C] | -10 | 45 | 32 | 45 | 996,2 | 3402 | 857,3 | 2,25 | 7,69 | 1,94 | 442,5 | 2,49 | 11,40 | opt | |
| [°F] | 14 | 113 | 90 | 113 | | | | | | | | | | | |
| [°C] | -25 | 45 | 32 | 45 | 539,2 | 1842 | 464,1 | 1,60 | 5,47 | 1,38 | 336,8 | 2,10 | 6,08 | opt | |
| [°F] | -13 | 113 | 90 | 113 | | | | | | | | | | | |

Performance tables

R290, 220V/50Hz, eRSCR, fan 3m/s, VDE, CCC, EAC

| | pe | | Cooling capacity | | | COP | EER | | P1 | I | m |
|------------------|------|------|------------------|---------|----------|------|-------|----------|-------|------|-------|
| | [°C] | [°F] | [W] | [Btu/h] | [kcal/h] | | [W/W] | [Btu/Wh] | | | |
| [°C / °F] | -25 | -13 | 539,2 | 1842 | 464,1 | 1,60 | 5,47 | 1,38 | 336,8 | 2,10 | 6,08 |
| cond. pressure | -20 | -4 | 667,3 | 2279 | 574,3 | 1,79 | 6,13 | 1,54 | 372,1 | 2,22 | 7,56 |
| pc= 45/113 | -15 | 5 | 819,1 | 2797 | 704,9 | 2,01 | 6,87 | 1,73 | 407,5 | 2,36 | 9,32 |
| return gas temp. | -10 | 14 | 996,2 | 3402 | 857,3 | 2,25 | 7,69 | 1,94 | 442,5 | 2,49 | 11,40 |
| RGT= 32/90 | 0 | 32 | 1433,1 | 4894 | 1233,3 | 2,81 | 9,61 | 2,42 | 509,3 | 2,76 | 16,62 |
| liquid temp | 5 | 41 | 1696,2 | 5793 | 1459,8 | 3,14 | 10,72 | 2,70 | 540,2 | 2,89 | 19,84 |
| Tliq= 45/113 | 10 | 50 | 1991,4 | 6801 | 1713,8 | 3,50 | 11,96 | 3,01 | 568,7 | 3,01 | 23,53 |
| [°C / °F] | -25 | -13 | 454,1 | 1551 | 390,8 | 1,27 | 4,34 | 1,09 | 357,1 | 2,17 | 5,65 |
| cond. pressure | -20 | -4 | 565,3 | 1931 | 486,5 | 1,42 | 4,85 | 1,22 | 397,9 | 2,32 | 7,07 |
| pc= 55/131 | -15 | 5 | 696,6 | 2379 | 599,5 | 1,58 | 5,39 | 1,36 | 441,0 | 2,49 | 8,76 |
| return gas temp | -10 | 14 | 849,7 | 2902 | 731,3 | 1,75 | 5,97 | 1,51 | 485,8 | 2,67 | 10,75 |
| RGT= 32/90 | 0 | 32 | 1227,9 | 4194 | 1056,8 | 2,12 | 7,25 | 1,83 | 578,7 | 3,07 | 15,77 |
| liquid temp | 5 | 41 | 1456,5 | 4974 | 1253,4 | 2,33 | 7,95 | 2,00 | 625,8 | 3,27 | 18,89 |
| Tliq= 55/131 | 10 | 50 | 1713,5 | 5852 | 1474,6 | 2,55 | 8,70 | 2,19 | 672,8 | 3,49 | 22,47 |