

Model

| | | | |
|-------------|----------------|-------------|-----------------|
| Designation | NLV10CN | Sales code: | 105H7003 |
|-------------|----------------|-------------|-----------------|

Compressor design

| | | | |
|----------------------------|---------------------------------|-----------------------|----------------------------------|
| Oil type | Polyolester | Refrigerant(s) | R290 |
| Oil viscosity | 32cST | Displacement | 10,09cm ³ / 0,62cu.in |
| Oil quantity | 298cm ³ / 10,1fl.oz | Compressors on pallet | 80 |
| Refr. charge - tech. limit | 300g / 10,6oz | | |
| Free gas volume comp. | 2360cm ³ / 79,8fl.oz | | |
| Weight | 10,8kg / 23,8lbs | | |
| Motor protection | 2# internal | | |
| Winding resist. ph. to ph. | 5,3Ω (at 25°C) | | |
| Max. winding temp. | 125°C / 257°F | | |
| Max. discharge temp. | 130°C / 266°F | | |



General - Configurations and Applications with NLV10CN and Controller

| | Conf. 1 | Conf. 2 | Conf. 3 | Conf. 4 |
|---------------------------|------------------|------------------|------------------|------------------|
| Sales code single pack: | 105N4910 | 105N4960 | 105N4962 | 105N4866 |
| Sales code industry pack: | 105N4911 | 105N4961 | 105N4963 | 105N4867 |
| Power supply (nominal) | 220-240V 50/60Hz | 100-240V 50/60Hz | 100-240V 50/60Hz | 100-240V 50/60Hz |
| Approvals | VDE,CCC | VDE,UL,CCC,CB | VDE,UL,CCC,CB | CCC,VDE,UL,CB |
| Refrigerant | R290 | R290 | R290 | R290 |
| Number of phases | 1~ AC | 1~ AC | 1~ AC | 1~ AC |
| Application | LBP+MBP | LBP+MBP | LBP+MBP | LBP+MBP |
| Starting torque | HST | HST | HST | HST |
| Hot gas defrost | OK | OK | OK | OK |
| Long interval pull down | OK | OK | OK | OK |
| System cooling | fan 3m/s | fan 3m/s | fan 3m/s | fan 3m/s |
| Note | - / - | | | |

Controller functions

| | Conf. 1 | Conf. 2 | Conf. 3 | Conf. 4 |
|-----------------------|----------------|----------------|--------------------|----------------|
| Protection | Mechanic | Mechanic | Mechanic | Mechanic |
| Max output power | 1000 W | 1000 W | 1000 W | 1000 W |
| No of relays | 2 | 2 | 2 | 8 |
| Hot gas defrost | yes | yes | yes | yes |
| AEO speed setting | yes | yes | yes | N |
| Serial com, (Modbus) | SWI | SWI | SWI | RS485 |
| DWI / Frequency input | yes | yes | yes | N |
| Note | | | US GFCI-Conformity | |

Model

Designation **NLV10CN**

Sales code: **105H7003**

Compressor dimensions

| | | |
|----------------|-------------------|----------------|
| Housing | A Height | 203mm / 7,99in |
| | B Height | 197mm / 7,76in |
| | C Length shell | 205mm / 8,07in |
| | D Length w. cover | 252mm / 9,92in |
| | E Width | 166mm / 6,54in |

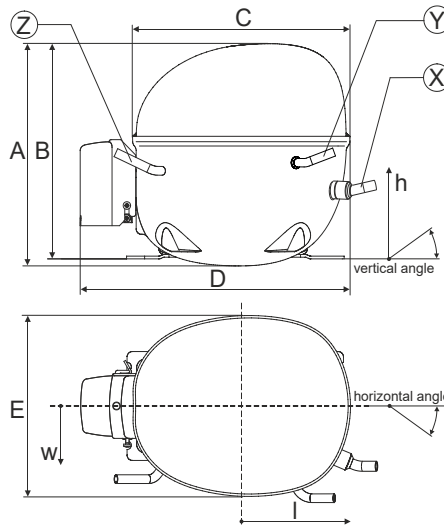

| Connectors | | Suction | Discharge | Process |
|------------------|----------------------------|--------------|--------------|--------------|
| | | X | Y | Z |
| Diameter | [mm] | øi 8,11-8,29 | øi 6,11-6,29 | øi 6,11-6,29 |
| | (i:inside, o:outside) [in] | øi 0,32-0,33 | øi 0,24-0,25 | øi 0,24-0,25 |
| Material | | copper | copper | copper |
| Horizontal angle | ±2° | 0° | 0° | 0° |
| Vertical angle | ±2° | 15° | 21° | 155° |
| Position l/h/w | [mm] | 132/69/57 | 94/102/81 | -109/94/72 |
| | [in] | 5,2/2,7/2,2 | 3,7/4/3,2 | -4,3/3,7/2,8 |
| Straight tube l. | [mm] | 12 | 12 | 12 |
| | [in] | 0,5 | 0,5 | 0,5 |

Compressor fixation

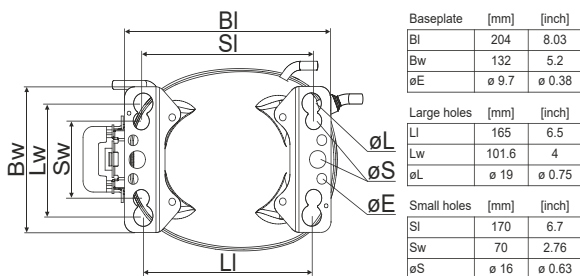

Bolt joint

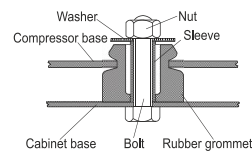

Snap-on

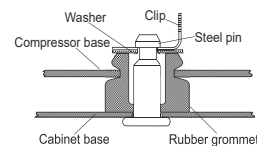

| Mounting accessories | one comp. | multi pack |
|----------------------------|-----------|------------|
| Bolt joint M6 ø16mm | 118-1917 | 118-1918 |
| Bolt joint ø1/4" ø16mm | 118-1946 | |
| Bolt joint ø1/4" ø19mm | 118-1949 | |
| Snap-on ø7,3 ø16mm | 118-1947 | 118-1919 |

Application notes

Operation possible until tilted up to 3 degrees

Provision for PE Grounding is located at the PE Stamp on the compressor

Model

| | | | | | |
|-------------------|--------------------|-------------------------|----------------|-------------|-----------------|
| Designation | NLV10CN | 220-240V 50/60Hz | Conf. 1 | Sales code: | 105H7003 |
| Controller | NLV MP 230V | | | | 105N4910 |

| | |
|------------------------------|--------------------|
| Sales code single pack: | 105N4910 (1 units) |
| Sales code industry pack: | 105N4911 (8 units) |
| Adaption to compressor: | detached |
| Protection class: | IP54 |
| Weight: | 1.4 kg / 3.08 lbs |
| Voltage nom.: | 220-240V 50/60Hz |
| Voltage range: | 180-270 V |
| Max. current: | 8,4 A (230 V) |
| LRA (Locked Rotor Amperage): | 1,2 A |
| Cable length: | 680 mm |
| Compressor speed range: | 2000-4500 rpm |
| Housing plastic: | UL94-5VA |

Controller dimensions:

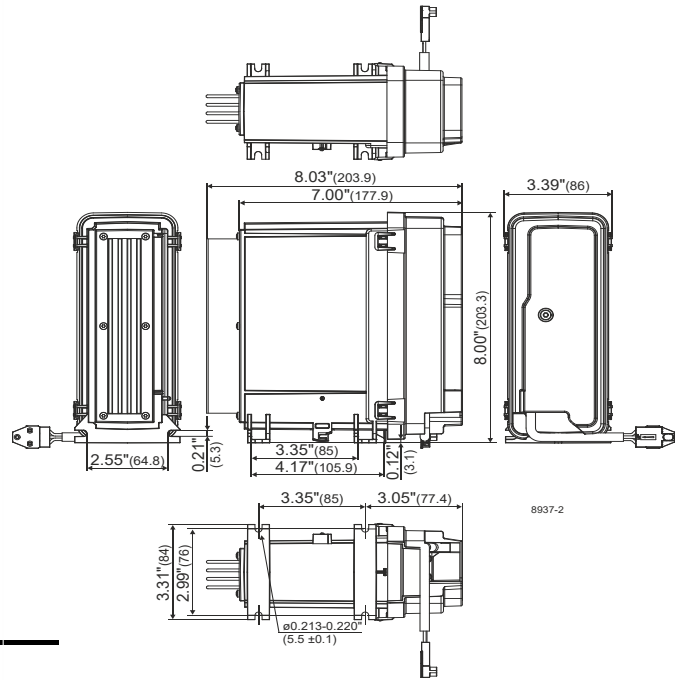

QR Code and Hyperlink leads to the [Operating Instructions.](#)

Operation Limits

Suctiongas temperature < +20°C (continuous operation)

System cooling

Ambient/ machineroom temperatures minimum /maximum

| | |
|--|------------------------|
| Ambient temperature range: | 10 - 43°C / 50 - 110°F |
| Machine room temperature range compressor: | 10 - 48°C / 50 - 119°F |
| Machine room temperature range controller: | 10 - 50°C / 50 - 122°F |

Compressor and Controller Cooling: Fan cooling 3m/s

Ensure proper airflow of 3 m/s at both compressor and electronic units.

The airflow for the electronics must be directed to the heat sink.

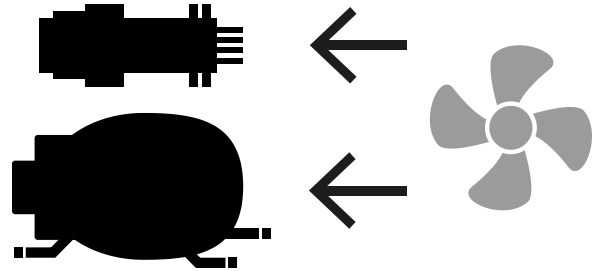

Operation pressure range

R290

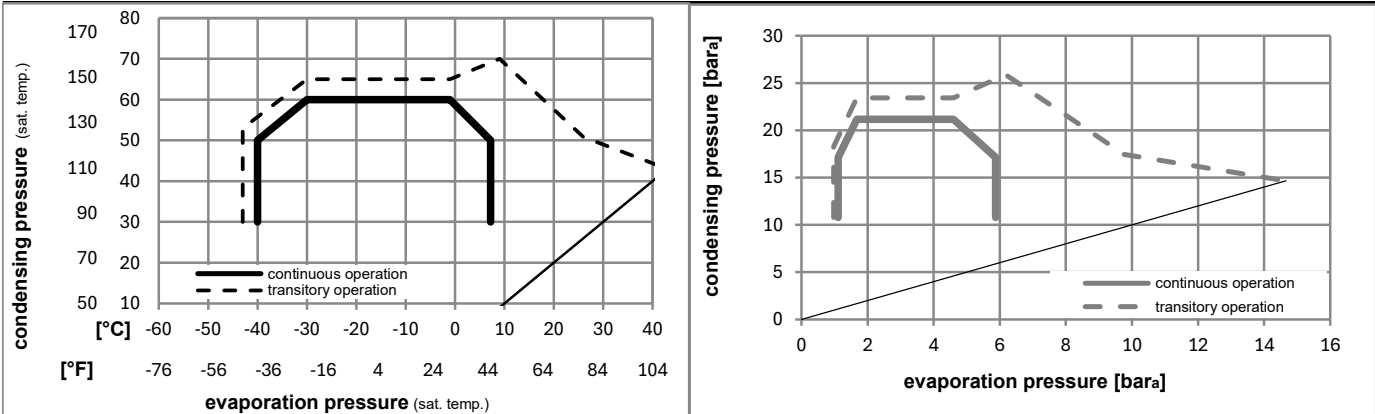

Model

| | | | | | |
|-------------|---------|------------------|---------|-------------|----------|
| Designation | NLV10CN | 220-240V 50/60Hz | Conf. 1 | Sales code: | 105H7003 |
|-------------|---------|------------------|---------|-------------|----------|

| | | | | | |
|------------|-------------|--|--|--|----------|
| Controller | NLV MP 230V | | | | 105N4910 |
|------------|-------------|--|--|--|----------|

Controller connections

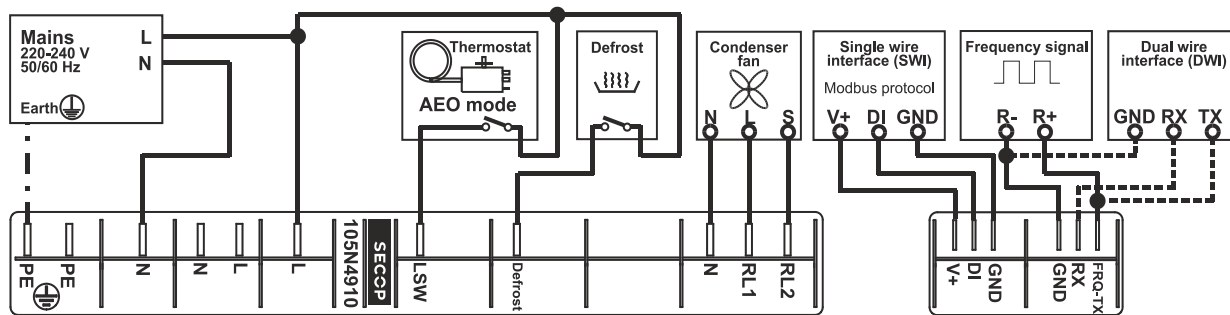
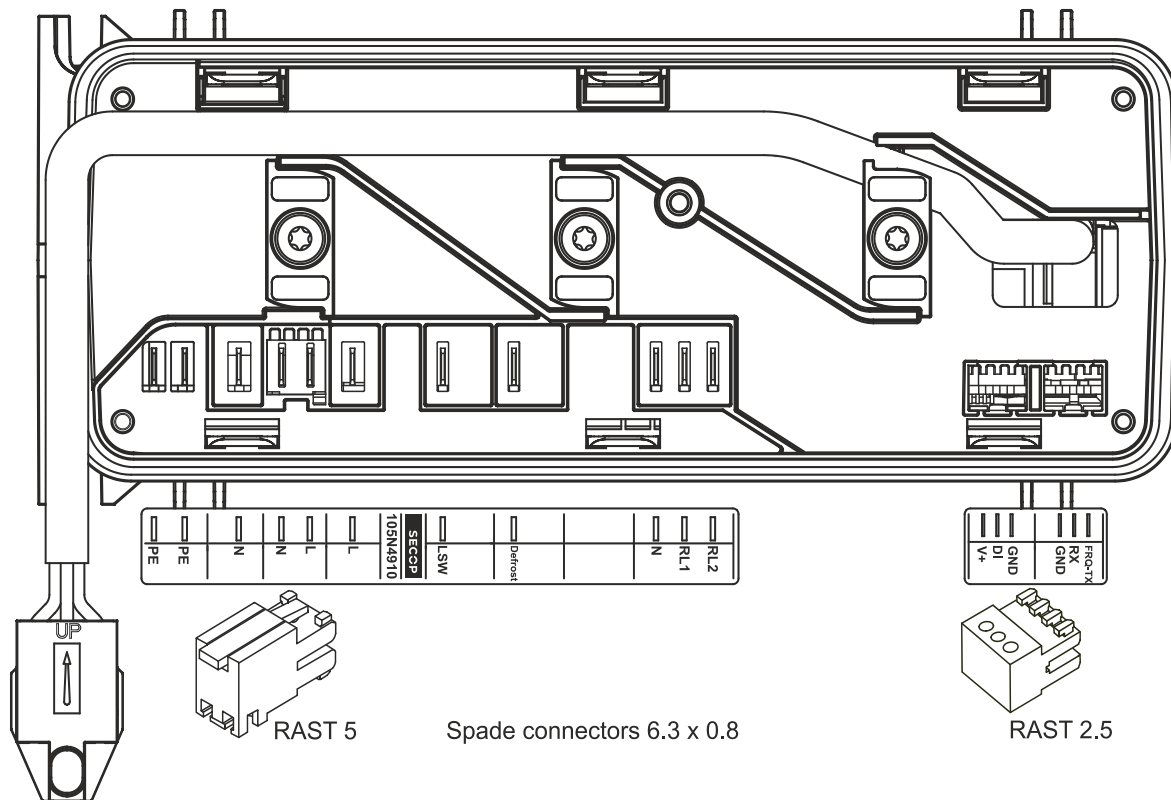

Accessories (Compressor + Controller) - check operation manual for details

| | | |
|----------|--------------------------------|--------|
| 103N2008 | plastic cover | 1 pcs |
| 103N9110 | plastic cover (MP of 103N2008) | 80 pcs |

Model

| | | | | | |
|-------------|--------------------|-------------------------|----------------|-------------|-----------------|
| Designation | NLV10CN | 220-240V 50/60Hz | Conf. 1 | Sales code: | 105H7003 |
| Controller | NLV MP 230V | | | | 105N4910 |

Optimization + standard conditions

R290, 220V, 50Hz, Rpm_N 4500, fan 3m/s

| | Evaporating pressure (saturation temperature) | | | | Condensing pressure (saturation temperature) | | | | | | Power consumption | | | ASHRAE LBP | |
|------|---|------|------------------|------|--|---------|----------|----------|-------|----------|---------------------|------|----------------|-------------|--|
| | pe | pc | Return gas temp. | | Cooling capacity | | | COP | EER | P1 | Current consumption | | Ref. mass flow | | |
| | | | RGT | Tliq | [W] | [Btu/h] | [kcal/h] | | | | I | m | | | |
| [°C] | [°F] | [°C] | [°F] | [°C] | [°F] | [W] | [Btu/h] | [kcal/h] | [W/W] | [Btu/Wh] | [kcal/Wh] | [W] | [A] | [kg/h] | |
| [°C] | -23 | 54 | 32 | 32 | 747,9 | 2554 | 643,7 | 1,76 | 6,01 | 1,52 | 424,8 | 2,21 | 7,57 | ASHRAE LBP | |
| [°F] | -10 | 130 | 90 | 90 | | | | | | | | | | | |
| [°C] | -25 | 55 | 32 | 55 | 560,5 | 1914 | 482,4 | 1,37 | 4,69 | 1,18 | 407,9 | 2,11 | 6,98 | cecomaf LBP | |
| [°F] | -13 | 131 | 90 | 131 | | | | | | | | | | | |
| [°C] | -35 | 40 | 20 | 40 | 412,3 | 1408 | 354,9 | 1,38 | 4,71 | 1,19 | 299,1 | 1,44 | 4,71 | EN12900 LBP | |
| [°F] | -31 | 104 | 68 | 104 | | | | | | | | | | | |
| [°C] | -7 | 54 | 35 | 46 | 1359,1 | 4641 | 1169,6 | 2,22 | 7,58 | 1,91 | 612,6 | 3,25 | 15,50 | ASHRAE MBP | |
| [°F] | 20 | 130 | 95 | 115 | | | | | | | | | | | |
| [°C] | -10 | 55 | 32 | 55 | 1077,4 | 3680 | 927,2 | 1,87 | 6,38 | 1,61 | 576,8 | 3,06 | 13,63 | cecomaf MBP | |
| [°F] | 14 | 131 | 90 | 131 | | | | | | | | | | | |
| [°C] | -10 | 45 | 20 | 45 | 1187,8 | 4057 | 1022,3 | 2,20 | 7,50 | 1,89 | 540,8 | 2,78 | 14,58 | EN12900 MBP | |
| [°F] | 14 | 113 | 68 | 113 | | | | | | | | | | | |

Standard conditions with different RPM

R290, 220V, 50Hz, Rpm_N 4500, fan 3m/s

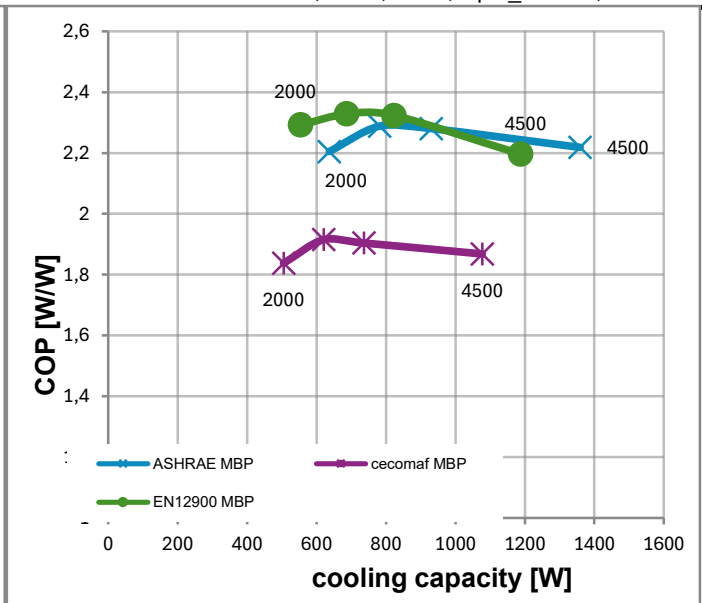
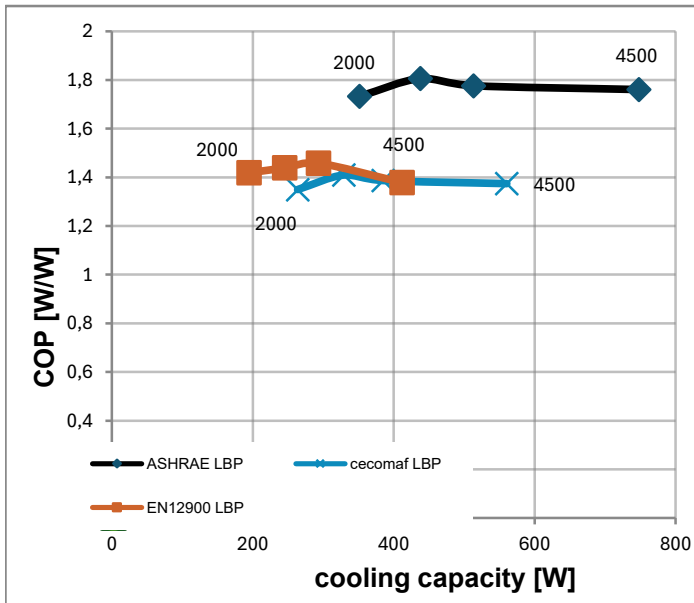

Test conditions:

| | pe [°C] | pc [°C] | Tliq [°C] | Tsuc [°C] | | pe [°C] | pc [°C] | Tliq [°C] | Tsuc [°C] |
|-------------|---------|---------|-----------|-----------|-------------|---------|---------|-----------|-----------|
| ASHRAE LBP | -23,33 | 54,44 | 32,22 | 32,22 | ASHRAE MBP | -6,66 | 54,44 | 46,11 | 35 |
| cecomaf LBP | -25 | 55 | 55 | 32 | cecomaf MBP | -10 | 55 | 55 | 32 |
| EN12900 LBP | -35 | 40 | 40 | 20 | EN12900 MBP | -10 | 45 | 45 | 20 |

Model

| | | | | | |
|-------------------|------------------|-------------------------|----------------|-------------|-----------------|
| Designation | NLV10CN | 100-240V 50/60Hz | Conf. 2 | Sales code: | 105H7003 |
| Controller | NLV MP MV | | | | 105N4960 |

| | |
|------------------------------|-------------------------------|
| Sales code single: | 105N4960 (1 units) |
| Sales code industry pack: | 105N4961 (8 units) |
| Adaption to compressor: | detached |
| Protection class: | IP54 |
| Weight: | 1.4 kg / 3.08 lbs |
| Voltage nom. | 100-240V 50/60Hz |
| Voltage range | 90-150/180-270 V |
| Max. current: | 4,2 A (230 V) / 8,4 A (115 V) |
| LRA (Locked Rotor Amperage): | 1,2 A |
| Cable length: | 680 mm |
| Compressor speed range: | 2000-4500 rpm |
| Housing plastic: | UL94-5VA |

Controller dimensions:

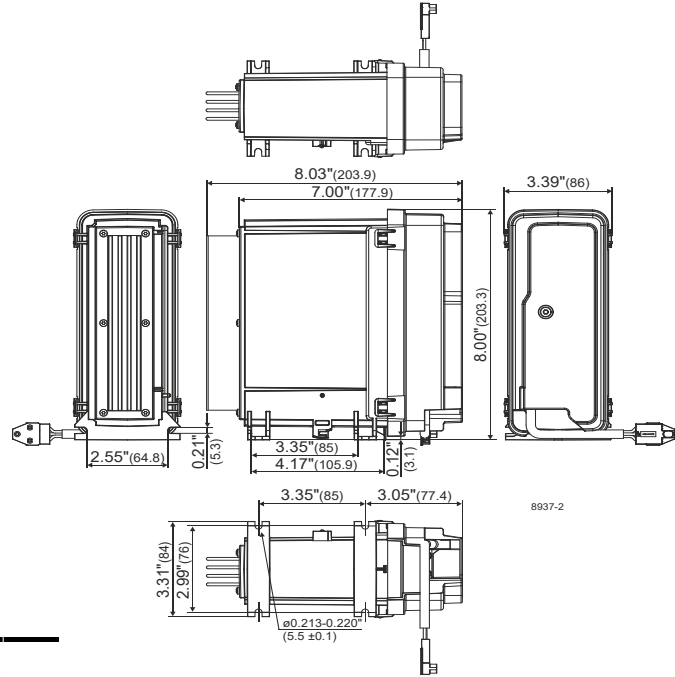

QR Code and Hyperlink leads to the [Operating Instructions.](#)

Operation Limits

Suctiongas temperature < +20°C (continuous operation)

System cooling

Ambient/ machineroom temperatures minimum /maximum

| | |
|--|------------------------|
| Ambient temperature range: | 10 - 43°C / 50 - 110°F |
| Machine room temperature range compressor: | 10 - 48°C / 50 - 119°F |
| Machine room temperature range controller: | 10 - 50°C / 50 - 122°F |

Compressor and Controller Cooling: Fan cooling 3m/s

Ensure proper airflow of 3 m/s at both compressor and electronic units.

The airflow for the electronics must be directed to the heat sink.

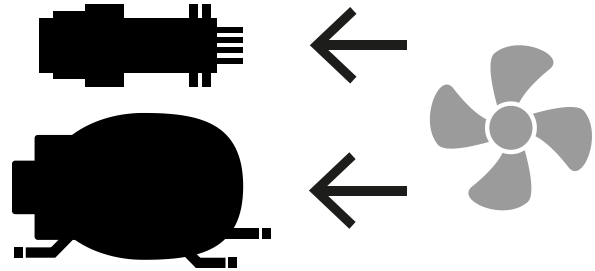

Operation pressure range

R290

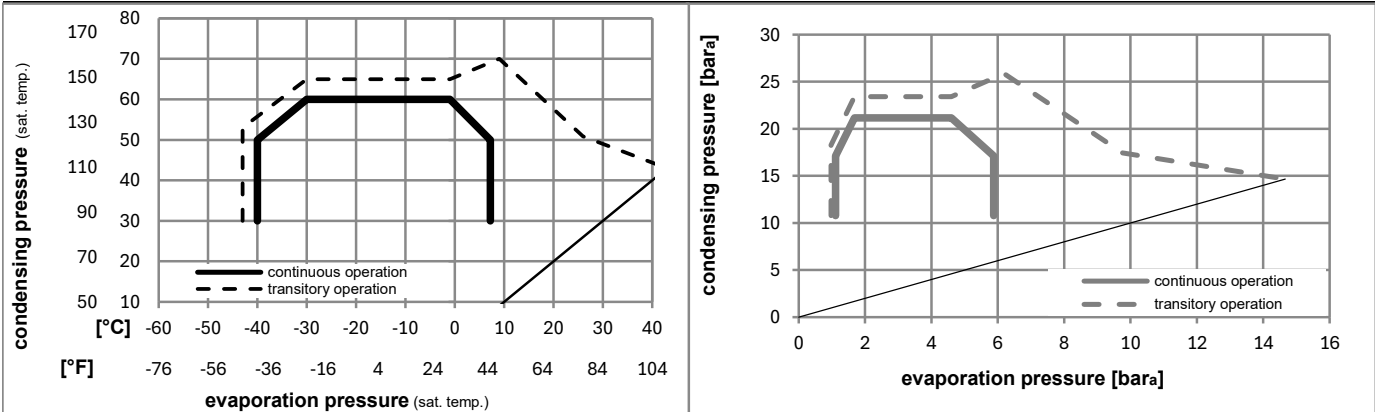

Model

| | | | | | |
|-------------|---------|------------------|---------|-------------|----------|
| Designation | NLV10CN | 100-240V 50/60Hz | Conf. 2 | Sales code: | 105H7003 |
|-------------|---------|------------------|---------|-------------|----------|

| | | | | | |
|------------|-----------|--|--|--|----------|
| Controller | NLV MP MV | | | | 105N4960 |
|------------|-----------|--|--|--|----------|

Controller connections

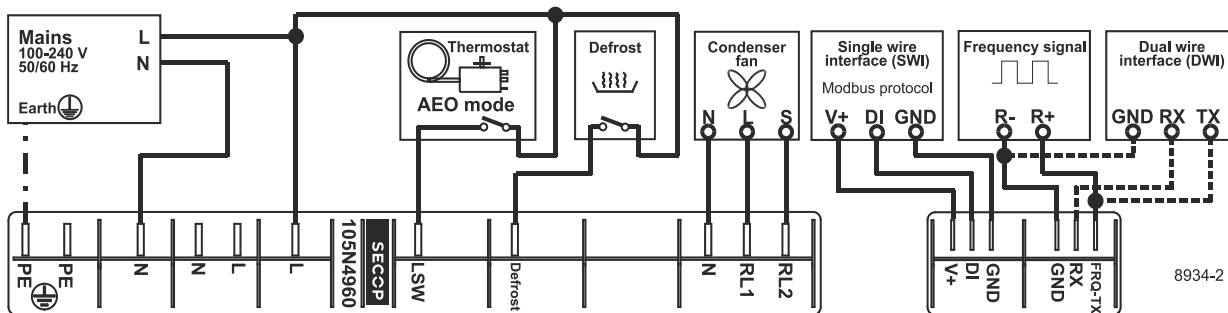
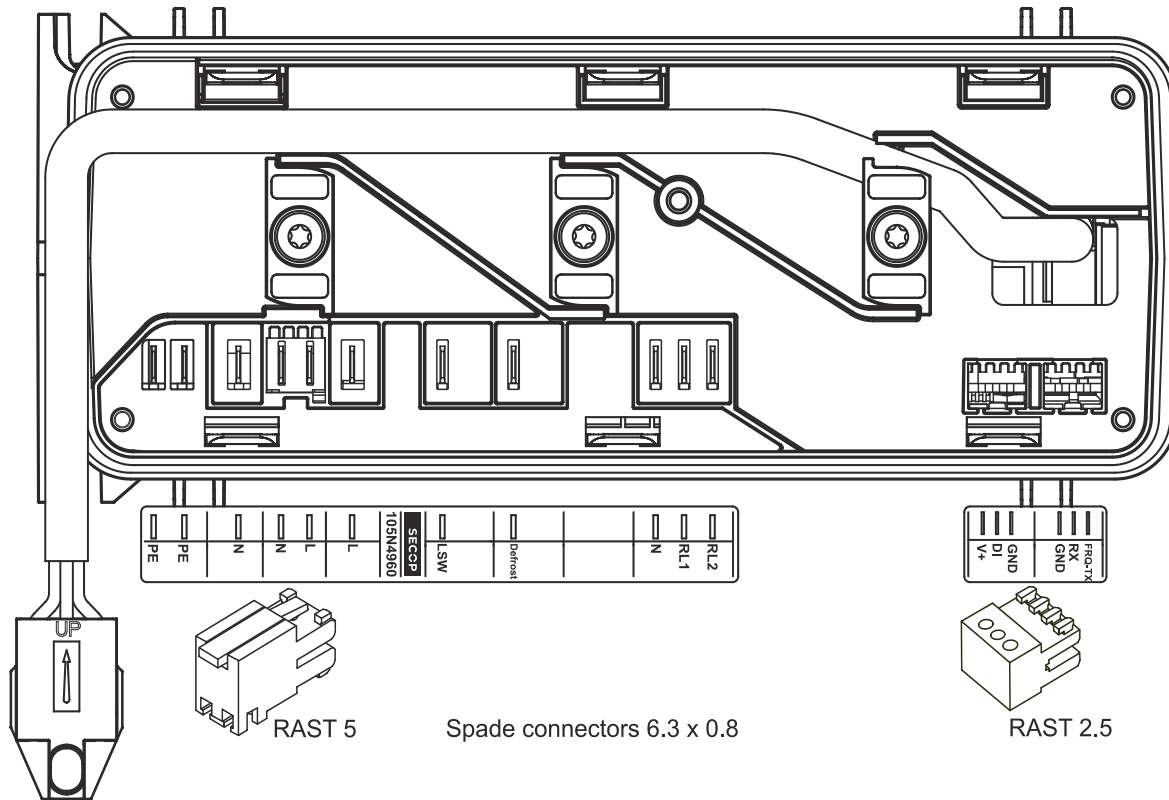

Accessories (Compressor + Controller) - check operation manual for details

| | | |
|----------|--------------------------------|--------|
| 103N2008 | plastic cover | 1 pcs |
| 103N9110 | plastic cover (MP of 103N2008) | 80 pcs |

Model

| | | | | | |
|-------------|------------------|-------------------------|----------------|-------------|-----------------|
| Designation | NLV10CN | 100-240V 50/60Hz | Conf. 2 | Sales code: | 105H7003 |
| Controller | NLV MP MV | | | | 105N4960 |

Optimization + standard conditions

R290, 220V, 50Hz, Rpm_N 4500, fan 3m/s

| | Evaporating pressure (saturation temperature) | | | | Condensing pressure (saturation temperature) | | | COP | EER | Power consumption | Current consumption | | Ref. mass flow | | | |
|--|---|------|------|------|--|--------------|------------------|---------|----------|-------------------|---------------------|-----------|----------------|------|--------|-------------|
| | pe | pc | RGT | Tliq | Return gas temp. | Liquid temp. | Cooling capacity | | | | P1 | I | | | m | |
| | [°C] | [°C] | [°C] | [°C] | [°C] | [°C] | [W] | [Btu/h] | [kcal/h] | [W/W] | [Btu/Wh] | [kcal/Wh] | [W] | [A] | [kg/h] | |
| | -23 | 54 | 32 | 32 | | | 747,9 | 2554 | 643,7 | 1,76 | 6,01 | 1,52 | 424,8 | 2,21 | 7,57 | ASHRAE LBP |
| | -10 | 130 | 90 | 90 | | | | | | | | | | | | |
| | -25 | 55 | 32 | 55 | | | 560,5 | 1914 | 482,4 | 1,37 | 4,69 | 1,18 | 407,9 | 2,11 | 6,98 | cecomaf LBP |
| | -13 | 131 | 90 | 131 | | | | | | | | | | | | |
| | -35 | 40 | 20 | 40 | | | 412,3 | 1408 | 354,9 | 1,38 | 4,71 | 1,19 | 299,1 | 1,44 | 4,71 | EN12900 LBP |
| | -31 | 104 | 68 | 104 | | | | | | | | | | | | |
| | -7 | 54 | 35 | 46 | | | 1359,1 | 4641 | 1169,6 | 2,22 | 7,58 | 1,91 | 612,6 | 3,25 | 15,50 | ASHRAE MBP |
| | 20 | 130 | 95 | 115 | | | | | | | | | | | | |
| | -10 | 55 | 32 | 55 | | | 1077,4 | 3680 | 927,2 | 1,87 | 6,38 | 1,61 | 576,8 | 3,06 | 13,63 | cecomaf MBP |
| | 14 | 131 | 90 | 131 | | | | | | | | | | | | |
| | -10 | 45 | 20 | 45 | | | 1187,8 | 4057 | 1022,3 | 2,20 | 7,50 | 1,89 | 540,8 | 2,78 | 14,58 | EN12900 MBP |
| | 14 | 113 | 68 | 113 | | | | | | | | | | | | |

Standard conditions with different RPM

R290, 220V, 50Hz, fan 3m/s

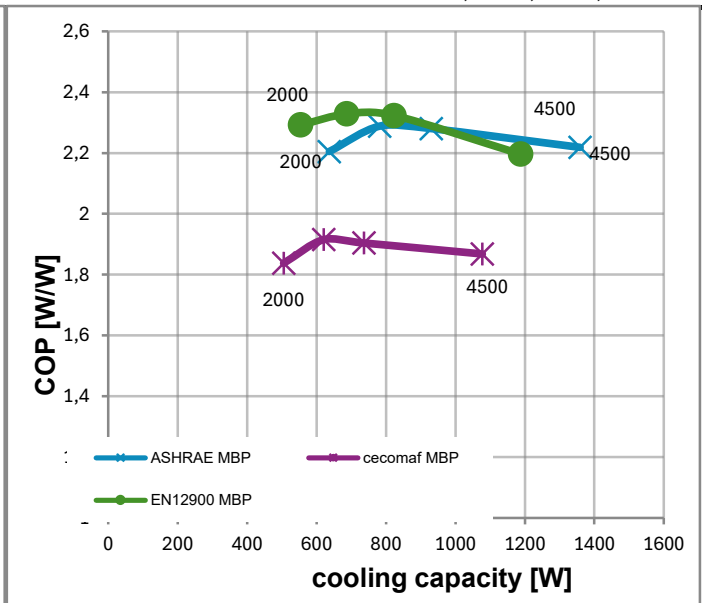
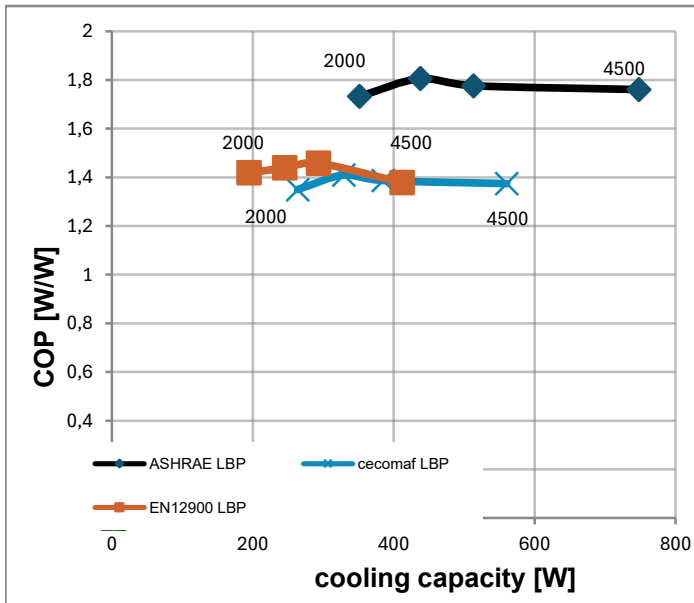

Test conditions:

| | pe [°C] | pc [°C] | Tliq [°C] | Tsuc [°C] | | pe [°C] | pc [°C] | Tliq [°C] | Tsuc [°C] |
|-------------|---------|---------|-----------|-----------|-------------|---------|---------|-----------|-----------|
| ASHRAE LBP | -23,33 | 54,44 | 32,22 | 32,22 | ASHRAE MBP | -6,66 | 54,44 | 46,11 | 35 |
| cecomaf LBP | -25 | 55 | 55 | 32 | cecomaf MBP | -10 | 55 | 55 | 32 |
| EN12900 LBP | -35 | 40 | 40 | 20 | EN12900 MBP | -10 | 45 | 45 | 20 |

Model

| | | | | | |
|-------------------|-----------------------|-------------------------|----------------|-------------|-----------------|
| Designation | NLV10CN | 100-240V 50/60Hz | Conf. 3 | Sales code: | 105H7003 |
| Controller | NLV MP MV GFCI | | | | 105N4962 |

| | |
|------------------------------|-------------------------------|
| Sales code single: | 105N4962 (1 units) |
| Sales code industry pack: | 105N4963 (8 units) |
| Adaption to compressor: | detached |
| Protection class: | IP54 |
| Weight: | 1.4 kg / 3.08 lbs |
| Voltage nom. | 100-240V 50/60Hz |
| Voltage range | 90-150/180-270 V |
| Max. current: | 4,2 A (230 V) / 8,4 A (115 V) |
| LRA (Locked Rotor Amperage): | 1,2 A |
| Cable length: | 915 mm |
| Compressor speed range: | 2000-4500 rpm |
| Housing plastic: | UL94-5VA |

Controller dimensions:

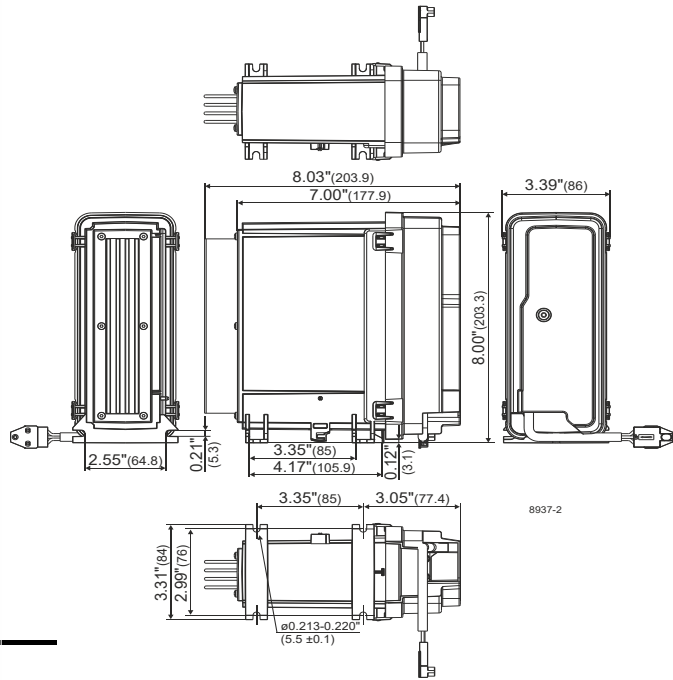

QR Code and Hyperlink leads to the [Operating Instructions.](#)

Operation Limits

Suctiongas temperature < +20°C (continuous operation)

System cooling

Ambient/ machineroom temperatures minimum /maximum

| | |
|--|------------------------|
| Ambient temperature range: | 10 - 43°C / 50 - 110°F |
| Machine room temperature range compressor: | 10 - 48°C / 50 - 119°F |
| Machine room temperature range controller: | 10 - 50°C / 50 - 122°F |

Compressor and Controller Cooling: Fan cooling 3m/s

Ensure proper airflow of 3 m/s at both compressor and electronic units.

The airflow for the electronics must be directed to the heat sink.

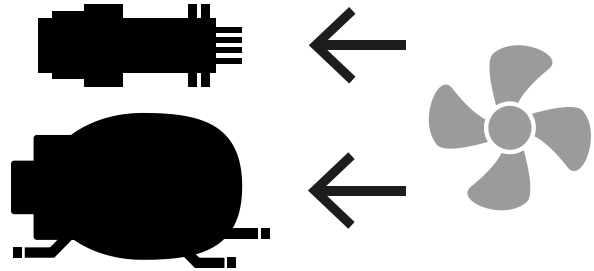

Operation pressure range

R290

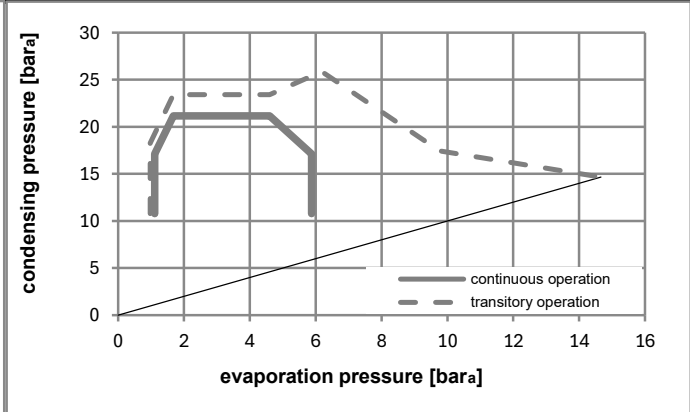
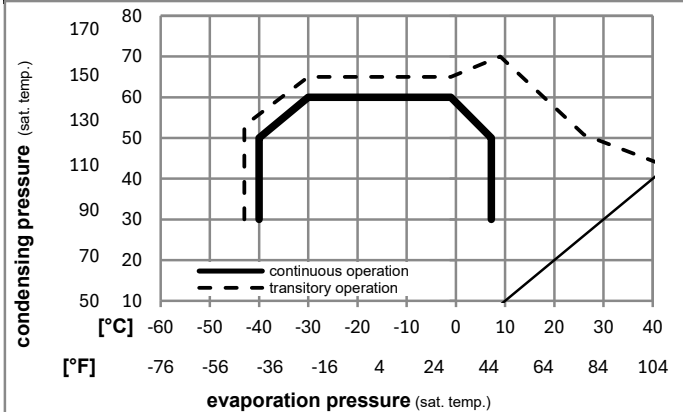

Model

| | | | | | |
|-------------|---------|------------------|---------|-------------|----------|
| Designation | NLV10CN | 100-240V 50/60Hz | Conf. 3 | Sales code: | 105H7003 |
|-------------|---------|------------------|---------|-------------|----------|

| | | |
|------------|----------------|----------|
| Controller | NLV MP MV GFCI | 105N4962 |
|------------|----------------|----------|

Controller connections

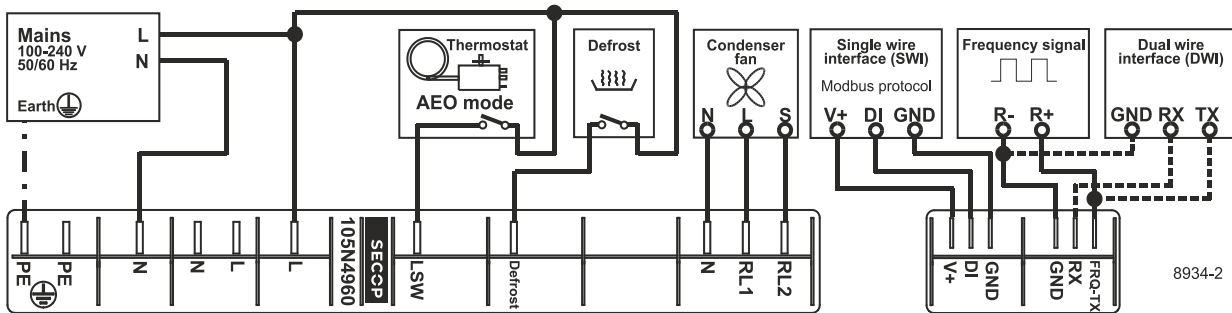
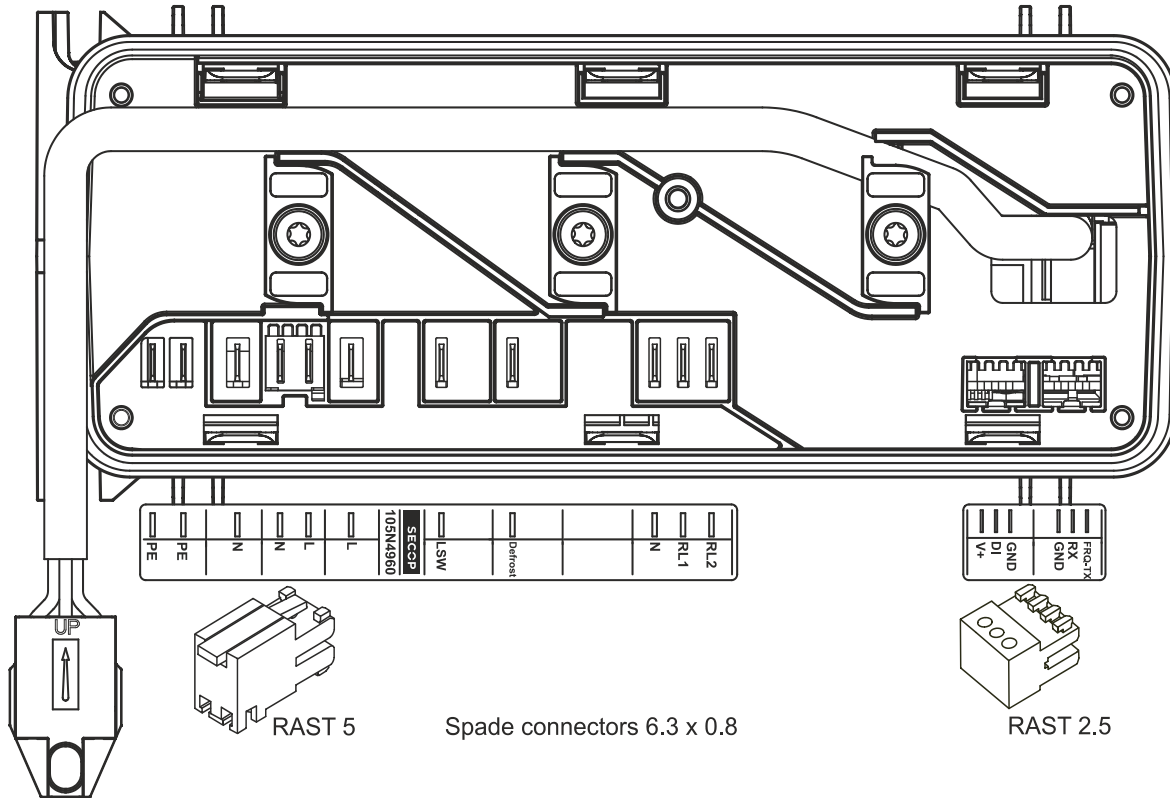

Accessories (Compressor + Controller) - check operation manual for details

| | | |
|----------|--------------------------------|--------|
| 103N2008 | plastic cover | 1 pcs |
| 103N9110 | plastic cover (MP of 103N2008) | 80 pcs |

Model

Designation **NLV10CN** **100-240V 50/60Hz** **Conf. 3** Sales code: **105H7003**

Controller **NLV MP MV GFCI** **105N4962**

Optimization + standard conditions

R290, 220V, 50Hz, Rpm_N 4500, fan 3m/s

| | Evaporating pressure (saturation temperature) | | | | Condensing pressure (saturation temperature) | | | | | | Power consumption | | | ASHRAE LBP |
|--|---|------|------|------|--|---------|----------|-------|----------|-----------|-------------------|----------------|--------|-------------|
| | pe | pc | RGT | Tliq | Cooling capacity | | | COP | EER | P1 | I | Ref. mass flow | | |
| | [°C] | [°C] | [°C] | [°C] | [W] | [Btu/h] | [kcal/h] | [W/W] | [Btu/Wh] | [kcal/Wh] | [W] | [A] | [kg/h] | |
| | -23 | 54 | 32 | 32 | 747,9 | 2554 | 643,7 | 1,76 | 6,01 | 1,52 | 424,8 | 2,21 | 7,57 | ASHRAE LBP |
| | [°F] | -10 | 130 | 90 | 90 | | | | | | | | | |
| | -25 | 55 | 32 | 55 | 560,5 | 1914 | 482,4 | 1,37 | 4,69 | 1,18 | 407,9 | 2,11 | 6,98 | cecomaf LBP |
| | [°F] | -13 | 131 | 90 | 131 | | | | | | | | | |
| | -35 | 40 | 20 | 40 | 412,3 | 1408 | 354,9 | 1,38 | 4,71 | 1,19 | 299,1 | 1,44 | 4,71 | EN12900 LBP |
| | [°F] | -31 | 104 | 68 | 104 | | | | | | | | | |
| | -7 | 54 | 35 | 46 | 1359,1 | 4641 | 1169,6 | 2,22 | 7,58 | 1,91 | 612,6 | 3,25 | 15,50 | ASHRAE MBP |
| | [°F] | 20 | 130 | 95 | 115 | | | | | | | | | |
| | -10 | 55 | 32 | 55 | 1077,4 | 3680 | 927,2 | 1,87 | 6,38 | 1,61 | 576,8 | 3,06 | 13,63 | cecomaf MBP |
| | [°F] | 14 | 131 | 90 | 131 | | | | | | | | | |
| | -10 | 45 | 20 | 45 | 1187,8 | 4057 | 1022,3 | 2,20 | 7,50 | 1,89 | 540,8 | 2,78 | 14,58 | EN12900 MBP |
| | [°F] | 14 | 113 | 68 | 113 | | | | | | | | | |

Standard conditions with different RPM

R290, 220V, 50Hz, fan 3m/s

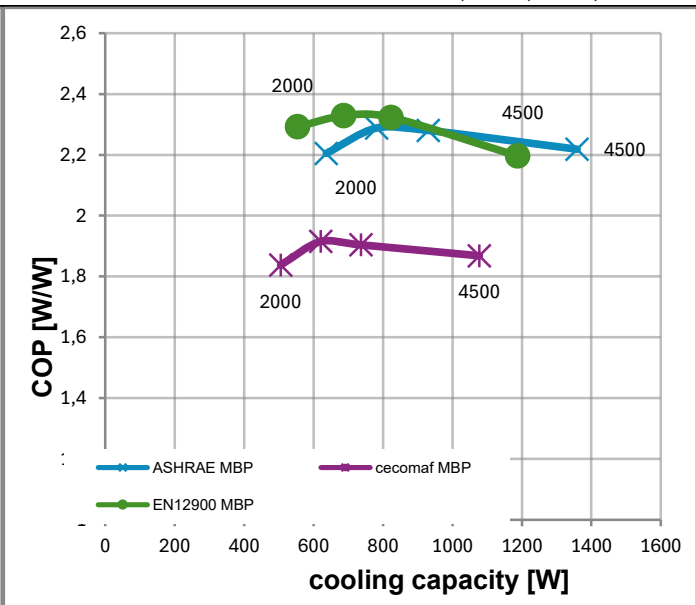
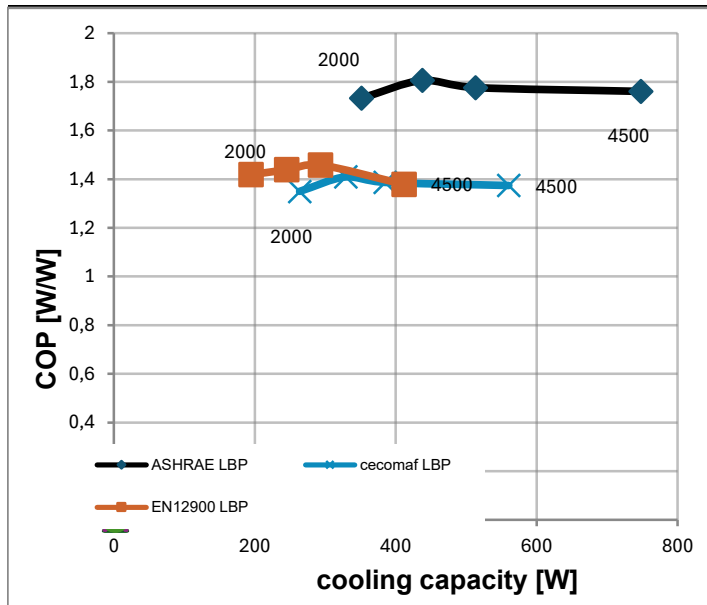

| Test conditions: | pe [°C] | pc [°C] | Tliq [°C] | Tsuc [°C] | pe [°C] | pc [°C] | Tliq [°C] | Tsuc [°C] | |
|------------------|---------|---------|-----------|-----------|-------------|---------|-----------|-----------|----|
| ASHRAE LBP | -23,33 | 54,44 | 32,22 | 32,22 | ASHRAE MBP | -6,66 | 54,44 | 46,11 | 35 |
| cecomaf LBP | -25 | 55 | 55 | 32 | cecomaf MBP | -10 | 55 | 55 | 32 |
| EN12900 LBP | -35 | 40 | 40 | 20 | EN12900 MBP | -10 | 45 | 45 | 20 |

Model

| | | | | | |
|-------------------|------------------|------------------------------|----------------|-------------|-----------------|
| Designation | NLV10CN | 100-240V 50/60Hz1~ AC | Conf. 4 | Sales code: | 105H7003 |
| Controller | NLV XT MV | | | | 105N4866 |

| | |
|------------------------------|-------------------------------|
| Sales code single: | 105N4866 (1 units) |
| Sales code industry pack: | 105N4867 (8 units) |
| Adaption to compressor: | detached |
| Protection class: | IP43 |
| Weight: | 1.5 kg / 3.3 lbs |
| Voltage nom. | 100-240V 50/60Hz1~ AC |
| Voltage range | 90-150/180-270 V |
| Max. current: | 4,2 A (230 V) / 8,4 A (115 V) |
| LRA (Locked Rotor Amperage): | 1,2 A |
| Cable length: | 630 mm |
| Compressor speed range: | 2000-4500 rpm |
| Housing plastic: | UL94-5VA |

Controller dimensions:

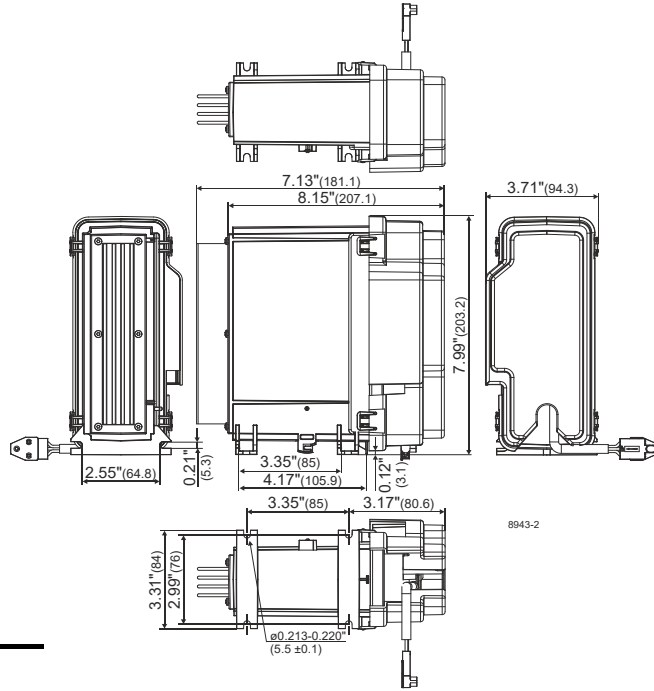

QR Code and Hyperlink leads to the [Operating Instructions.](#)

Operation Limits

Suctiongas temperature < +20°C (continuous operation)

System cooling

Ambient/ machineroom temperatures minimum /maximum

| | |
|--|------------------------|
| Ambient temperature range: | 10 - 43°C / 50 - 110°F |
| Machine room temperature range compressor: | 10 - 48°C / 50 - 119°F |
| Machine room temperature range controller: | 10 - 50°C / 50 - 122°F |

Compressor and Controller Cooling: Fan cooling 3m/s

Ensure proper airflow of 3 m/s at both compressor and electronic units.

The airflow for the electronics must be directed to the heat sink.

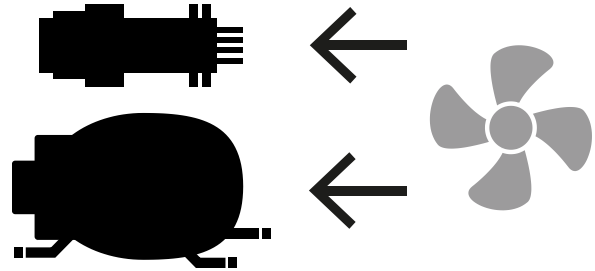

Operation pressure range

R290

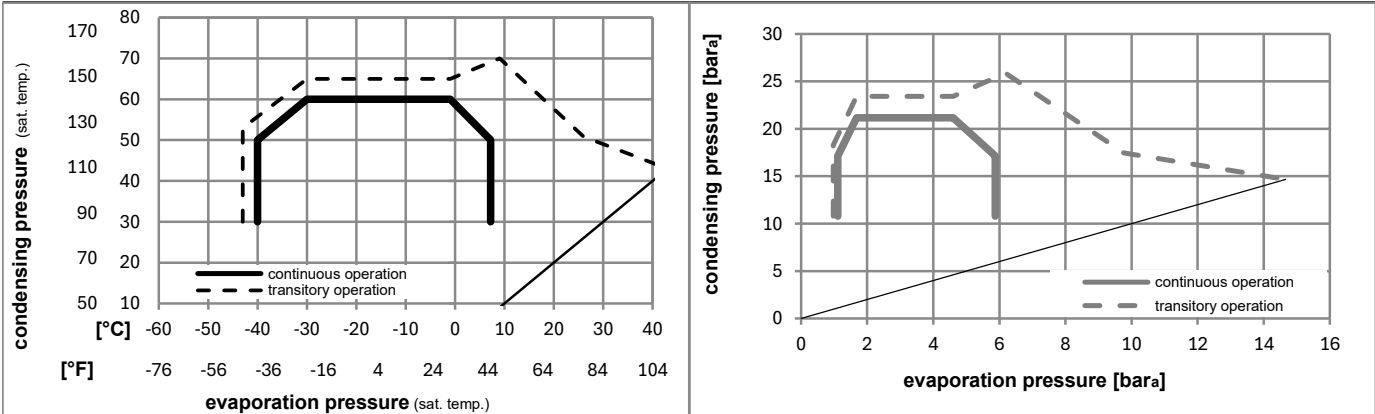

Model

| | | | | | |
|-------------|----------------|------------------------------|----------------|-------------|-----------------|
| Designation | NLV10CN | 100-240V 50/60Hz1~ AC | Conf. 4 | Sales code: | 105H7003 |
|-------------|----------------|------------------------------|----------------|-------------|-----------------|

| | | | | | |
|------------|------------------|--|--|--|-----------------|
| Controller | NLV XT MV | | | | 105N4866 |
|------------|------------------|--|--|--|-----------------|

Controller connections

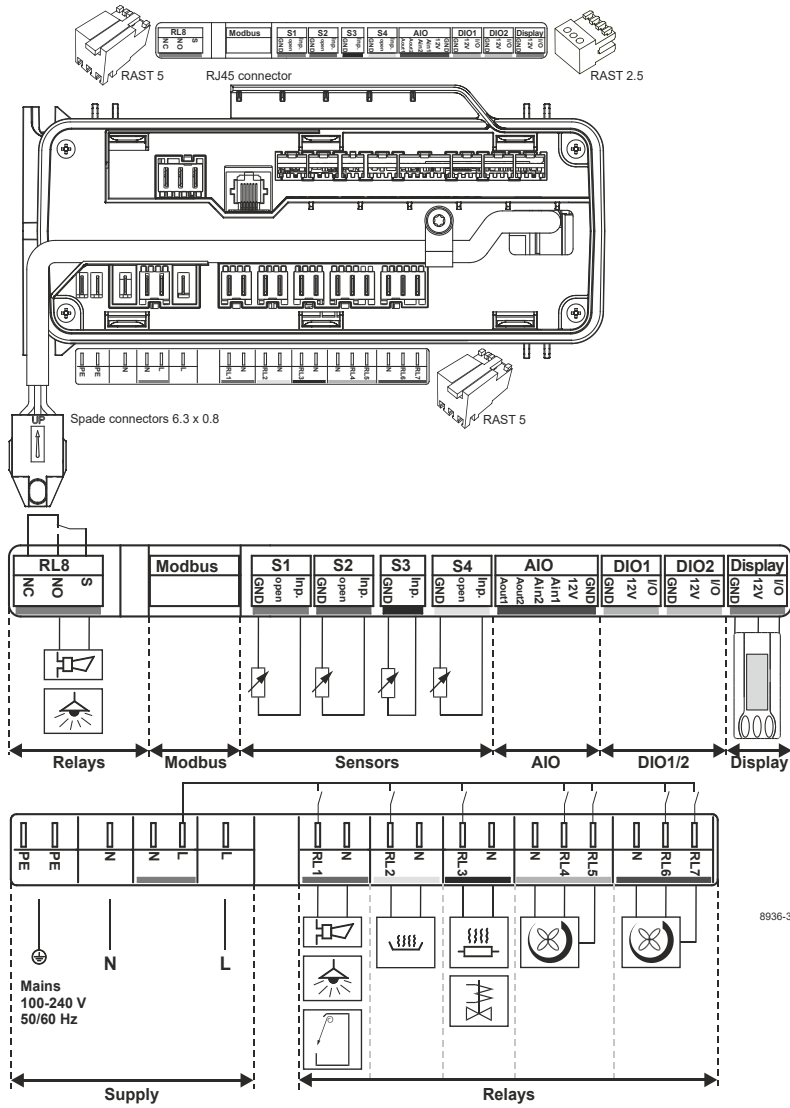

Accessories (Compressor + Controller) - check operation manual for details

| | | |
|----------|--------------------------------|--------|
| 103N2008 | plastic cover | 1 pcs |
| 103N9110 | plastic cover (MP of 103N2008) | 80 pcs |

Model

| | | | | | |
|-------------|------------------|------------------------------|----------------|-------------|-----------------|
| Designation | NLV10CN | 100-240V 50/60Hz1~ AC | Conf. 4 | Sales code: | 105H7003 |
| Controller | NLV XT MV | | | | 105N4866 |

Optimization + standard conditions

R290, 220V, 50Hz, Rpm_N 4500, fan 3m/s

| | Evaporating pressure (saturation temperature) | | | | Condensing pressure (saturation temperature) | | | COP | EER | Power consumption | Current consumption | | Ref. mass flow | | | |
|-------------|---|------|------|------|--|--------------|--------|---------|----------|-------------------|---------------------|-----------|----------------|-----|--------|---|
| | pe | pc | RGT | Tliq | Return gas temp. | Liquid temp. | W | | | | [Btu/h] | [kcal/h] | | | P1 | I |
| | [°C] | [°F] | [°C] | [°F] | [°C] | [°F] | [W] | [Btu/h] | [kcal/h] | [W/W] | [Btu/Wh] | [kcal/Wh] | [W] | [A] | [kg/h] | |
| ASHRAE LBP | -23 | 54 | 32 | 32 | 747,9 | 2554 | 643,7 | 1,76 | 6,01 | 1,52 | 424,8 | 2,21 | 7,57 | | | |
| cecomaf LBP | -25 | 55 | 32 | 55 | 560,5 | 1914 | 482,4 | 1,37 | 4,69 | 1,18 | 407,9 | 2,11 | 6,98 | | | |
| EN12900 LBP | -35 | 40 | 20 | 40 | 412,3 | 1408 | 354,9 | 1,38 | 4,71 | 1,19 | 299,1 | 1,44 | 4,71 | | | |
| ASHRAE MBP | -7 | 54 | 35 | 46 | 1359,1 | 4641 | 1169,6 | 2,22 | 7,58 | 1,91 | 612,6 | 3,25 | 15,50 | | | |
| cecomaf MBP | -10 | 55 | 32 | 55 | 1077,4 | 3680 | 927,2 | 1,87 | 6,38 | 1,61 | 576,8 | 3,06 | 13,63 | | | |
| EN12900 MBP | -10 | 45 | 20 | 45 | 1187,8 | 4057 | 1022,3 | 2,20 | 7,50 | 1,89 | 540,8 | 2,78 | 14,58 | | | |

Standard conditions with different RPM

R290, 220V, 50Hz, fan 3m/s

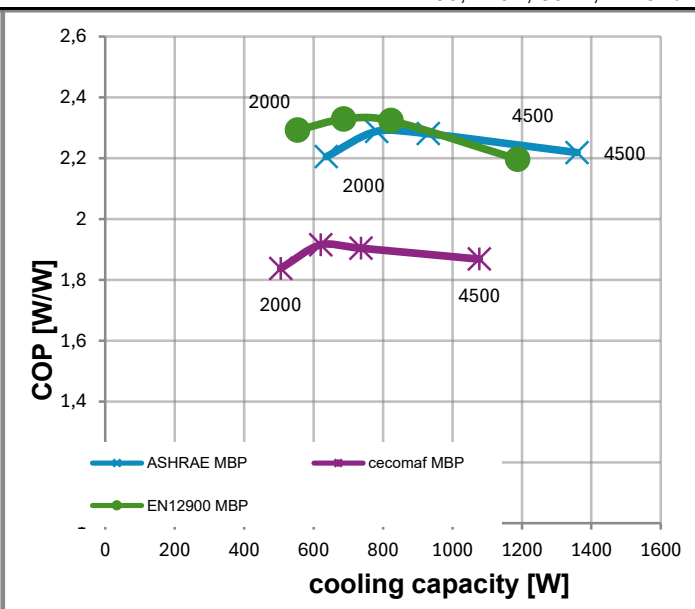
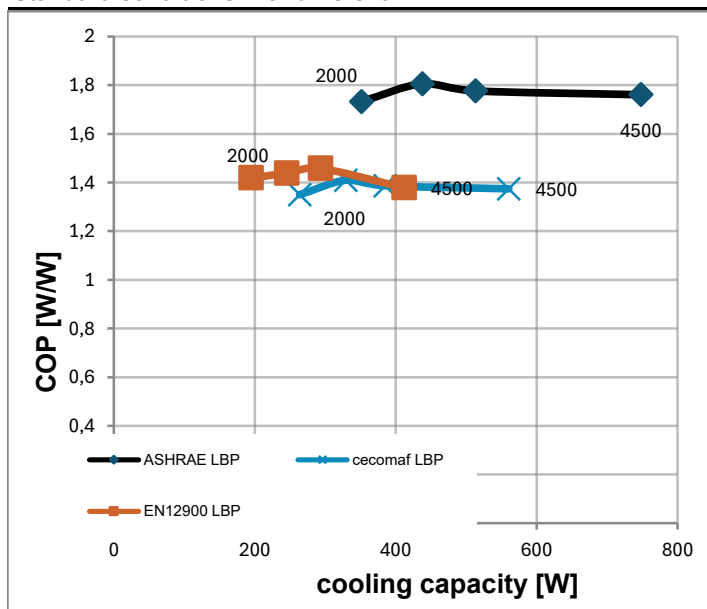

| Test conditions: | pe [°C] | pc [°C] | Tliq [°C] | Tsuc [°C] | pe [°C] | pc [°C] | Tliq [°C] | Tsuc [°C] | |
|------------------|---------|---------|-----------|-----------|-------------|---------|-----------|-----------|----|
| ASHRAE LBP | -23,33 | 54,44 | 32,22 | 32,22 | ASHRAE MBP | -6,66 | 54,44 | 46,11 | 35 |
| cecomaf LBP | -25 | 55 | 55 | 32 | cecomaf MBP | -10 | 55 | 55 | 32 |
| EN12900 LBP | -35 | 40 | 40 | 20 | EN12900 MBP | -10 | 45 | 45 | 20 |