

Model

Designation	NLV8.0CN	Sales code:	105H7808
-------------	-----------------	-------------	-----------------

Compressor design

Oil type	Polyolester	Refrigerant(s)	R290
Oil viscosity	32cST	Displacement	7,96cm ³ / 0,49cu.in
Oil quantity	298cm ³ / 10,1fl.oz	Compressors on pallet	80
Refr. charge - tech. limit	300g / 10,6oz		
Free gas volume comp.	2360cm ³ / 79,8fl.oz		
Weight	10,8kg / 23,8lbs		
Motor protection	2# internal		
Winding resist. ph. to ph.	5,3Ω (at 25°C)		
Max. winding temp.	125°C / 257°F		
Max. discharge temp.	130°C / 266°F		



General - Configurations and Applications with NLV8.0CN and Controller

	Conf. 1	Conf. 2	Conf. 3	Conf. 4
Sales code single pack:	105N4910	105N4960	105N4962	105N4866
Sales code industry pack:	105N4911	105N4961	105N4963	105N4867
Power supply (nominal)	220-240V 50/60Hz	100-240V 50/60Hz	100-240V 50/60Hz	100-240V 50/60Hz
Approvals	VDE,CCC	VDE,UL,CCC,CB	VDE,UL,CCC,CB	CCC,VDE,UL,CB
Refrigerant	R290	R290	R290	R290
Number of phases	1~ AC	1~ AC	1~ AC	1~ AC
Application	LBP+MBP	LBP+MBP	LBP+MBP	LBP+MBP
Starting torque	HST	HST	HST	HST
Hot gas defrost	OK	OK	OK	OK
Long interval pull down	OK	OK	OK	OK
System cooling	fan 3m/s	fan 3m/s	fan 3m/s	fan 3m/s
Note	- / -			

Controller functions

	Conf. 1	Conf. 2	Conf. 3	Conf. 4
Protection	Mechanic	Mechanic	Mechanic	Mechanic
Max output power	1000 W	1000 W	1000 W	1000 W
No of relays	2	2	2	8
Hot gas defrost	yes	yes	yes	yes
AEO speed setting	yes	yes	yes	N
Serial com, (Modbus)	SWI	SWI	SWI	RS485
DWI / Frequency input	yes	yes	yes	N
Note			US GFCI-Conformity	

Model

Designation **NLV8.0CN**

Sales code: **105H7808**

Compressor dimensions

Housing	A Height	203mm / 7,99in
	B Height	197mm / 7,76in
	C Length shell	205mm / 8,07in
	D Length w. cover	252mm / 9,92in
	E Width	166mm / 6,54in

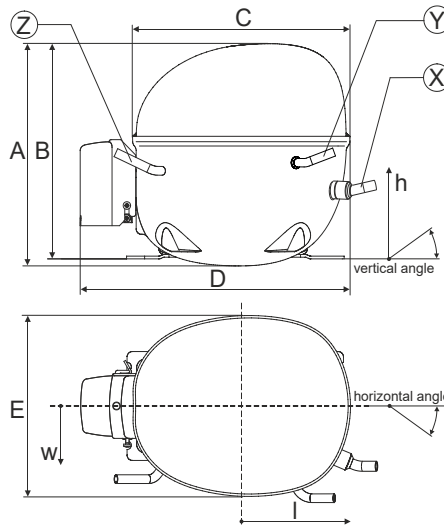

Connectors		Suction	Discharge	Process
		X	Y	Z
Diameter	[mm]	øi 8,11-8,29	øi 6,11-6,29	øi 6,11-6,29
(i:inside, o:outside)	[in]	øi 0,32-0,33	øi 0,24-0,25	øi 0,24-0,25
Material		copper	copper	copper
Horizontal angle	±2°	0°	0°	0°
Vertical angle	±2°	15°	21°	155°
Position l/h/w	[mm]	132/69/57	94/102/81	-109/94/72
	[in]	5,2/2,7/2,2	3,7/4/3,2	-4,3/3,7/2,8
Straight tube l.	[mm]	12	12	12
	[in]	0,5	0,5	0,5

Compressor fixation

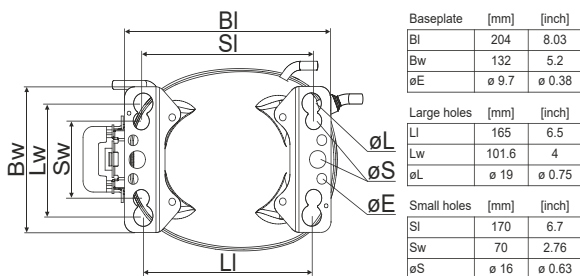

Bolt joint

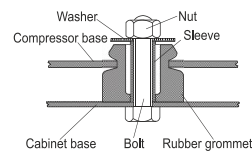

Snap-on

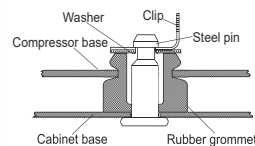

Mounting accessories	one comp.	multi pack
Bolt joint M6 ø16mm	118-1917	118-1918
Bolt joint ø1/4" ø16mm	118-1946	
Bolt joint ø1/4" ø19mm	118-1949	
Snap-on ø7,3 ø16mm	118-1947	118-1919

Application notes

Operation possible until tilted up to 3 degrees

Provision for PE Grounding is located at the PE Stamp on the compressor

Model

Designation	NLV8.0CN	220-240V 50/60Hz	Conf. 1	Sales code:	105H7808
Controller	NLV MP 230V				105N4910

Sales code single pack:	105N4910 (1 units)
Sales code industry pack:	105N4911 (8 units)
Adaption to compressor:	detached
Protection class:	IP54
Weight:	1.4 kg / 3.08 lbs
Voltage nom.:	220-240V 50/60Hz
Voltage range:	180-270 V
Max. current:	8,4 A (230 V)
LRA (Locked Rotor Amperage):	1,2 A
Cable length:	680 mm
Compressor speed range:	2000-4500 rpm
Housing plastic:	UL94-5VA

Controller dimensions:

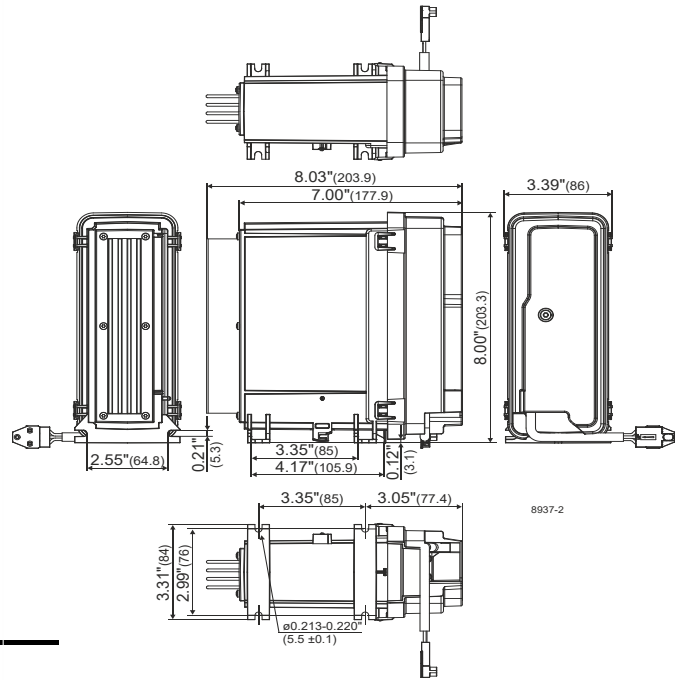

QR Code and Hyperlink leads to the [Operating Instructions.](#)

Operation Limits

Suctiongas temperature < +20°C (continuous operation)

System cooling

Ambient/ machineroom temperatures minimum /maximum

Ambient temperature range:	10 - 43°C / 50 - 110°F
Machine room temperature range compressor:	10 - 48°C / 50 - 119°F
Machine room temperature range controller:	10 - 50°C / 50 - 122°F

Compressor and Controller Cooling: Fan cooling 3m/s

Ensure proper airflow of 3 m/s at both compressor and electronic units.

The airflow for the electronics must be directed to the heat sink.

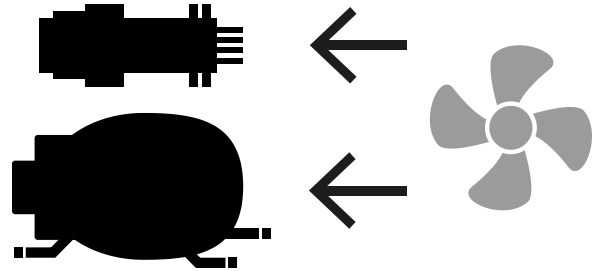

Operation pressure range

R290

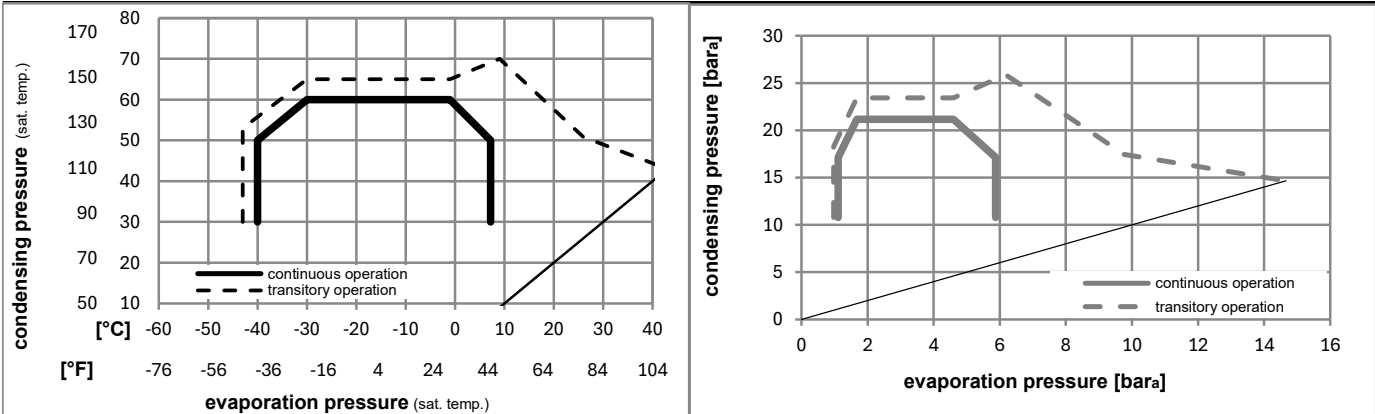

Model

Designation **NLV8.0CN** **220-240V 50/60Hz** **Conf. 1** Sales code: **105H7808**

Controller **NLV MP 230V** **105N4910**

Controller connections

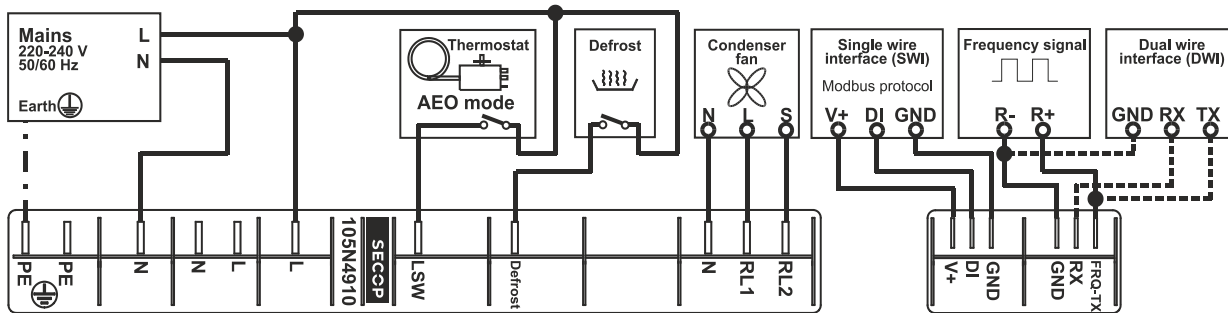
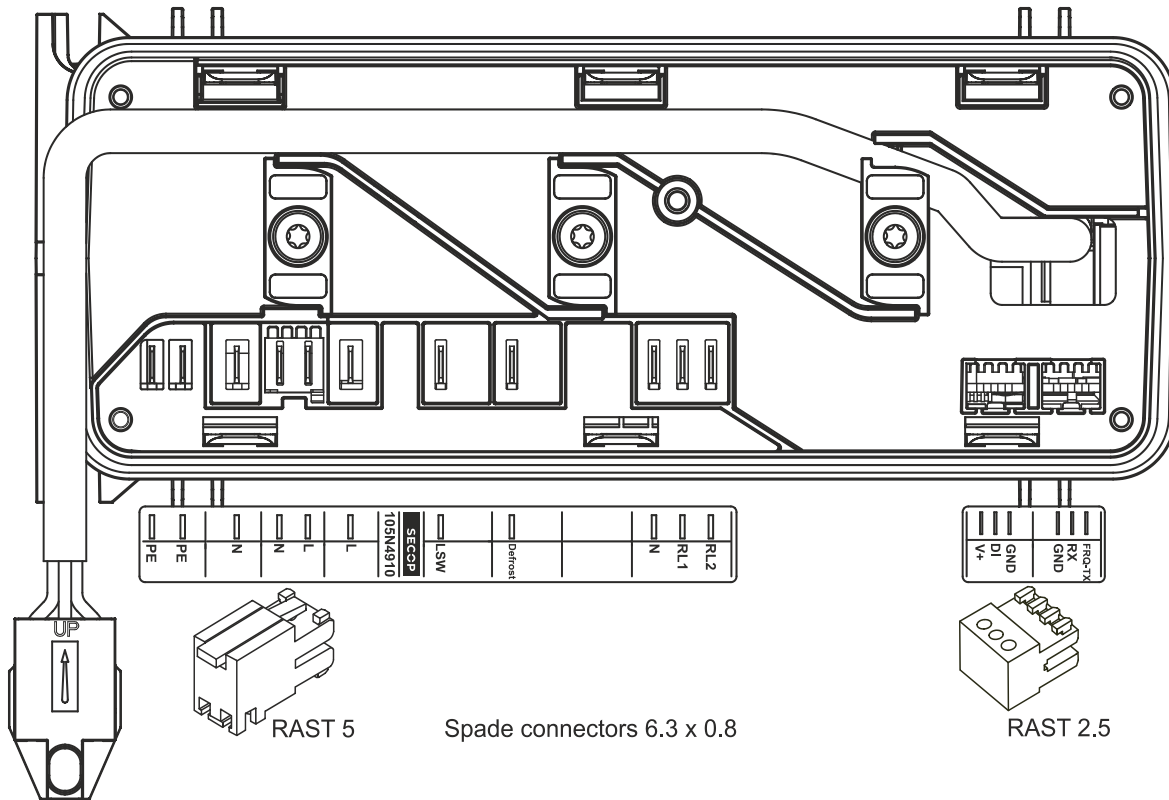

Accessories (Compressor + Controller) - check operation manual for details

103N2008	plastic cover	1 pcs
103N9110	plastic cover (MP of 103N2008)	80 pcs

Model

Designation	NLV8.0CN	220-240V 50/60Hz	Conf. 1	Sales code:	105H7808
Controller	NLV MP 230V				105N4910

Optimization + standard conditions

R290, 220V, 50Hz, Rpm_N 4500, fan 3m/s

	Evaporating pressure (saturation temperature)				Condensing pressure (saturation temperature)			COP	EER	Cooling capacity	Power consumption			ASHRAE LBP
	pe	pc	RGT	Tliq	[W]	[Btu/h]	[kcal/h]				P1	I	ṁ	
[°C]	-23	54	32	32	556,7	1901	479,1	1,72	5,87	1,48	323,9	1,72	5,64	ASHRAE LBP
[°F]	-10	130	90	90										
[°C]	-25	55	32	55	414,7	1416	356,9	1,33	4,55	1,15	311,4	1,65	5,16	cecomaf LBP
[°F]	-13	131	90	131										
[°C]	-35	40	20	40	316,3	1080	272,2	1,40	4,78	1,20	226,0	0,96	3,61	EN12900 LBP
[°F]	-31	104	68	104										
[°C]	-7	54	35	46	1050,0	3586	903,6	2,29	7,82	1,97	458,3	2,42	11,98	ASHRAE MBP
[°F]	20	130	95	115										
[°C]	-10	55	32	55	826,8	2824	711,6	1,91	6,51	1,64	433,6	2,27	10,46	cecomaf MBP
[°F]	14	131	90	131										
[°C]	-10	45	20	45	940,6	3212	809,5	2,29	7,82	1,97	410,6	2,11	11,55	EN12900 MBP
[°F]	14	113	68	113										

Standard conditions with different RPM

R290, 220V, 50Hz, Rpm_N 4500, fan 3m/s

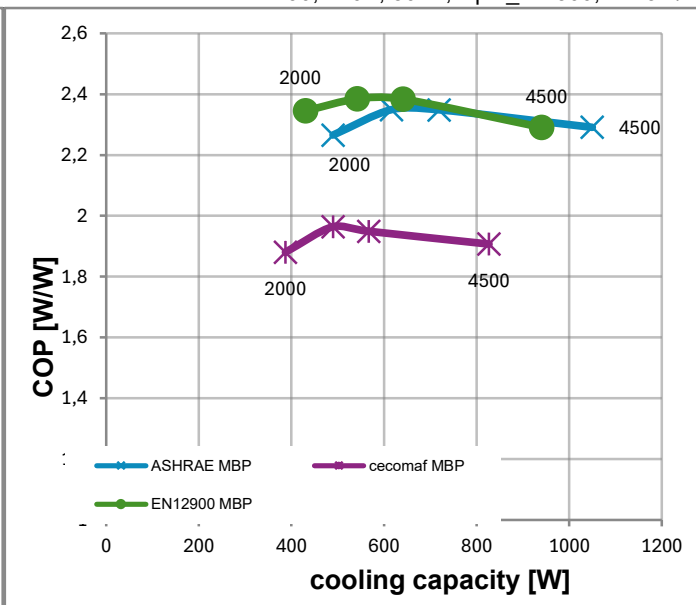
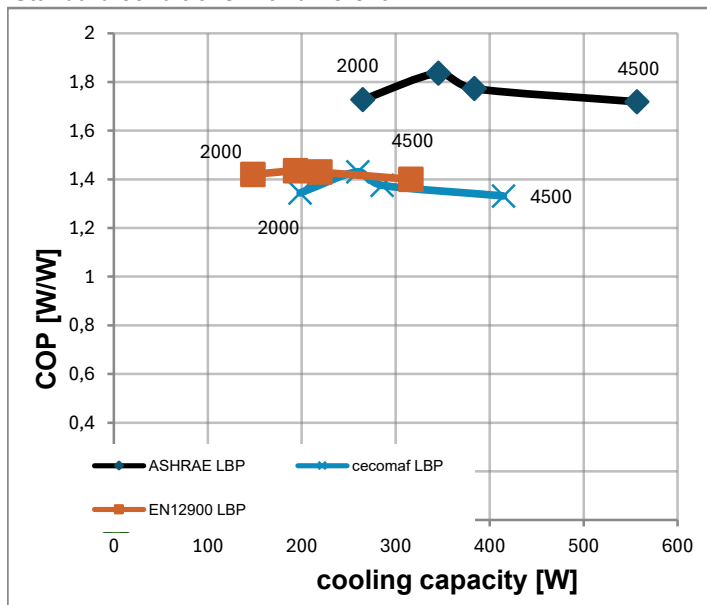

Test conditions:

	pe [°C]	pc [°C]	Tliq [°C]	Tsuc [°C]		pe [°C]	pc [°C]	Tliq [°C]	Tsuc [°C]
ASHRAE LBP	-23,33	54,44	32,22	32,22	ASHRAE MBP	-6,66	54,44	46,11	35
cecomaf LBP	-25	55	55	32	cecomaf MBP	-10	55	55	32
EN12900 LBP	-35	40	40	20	EN12900 MBP	-10	45	45	20

Model

Designation	NLV8.0CN	100-240V 50/60Hz	Conf. 2	Sales code:	105H7808
Controller	NLV MP MV				105N4960

Sales code single:	105N4960 (1 units)
Sales code industry pack:	105N4961 (8 units)
Adaption to compressor:	detached
Protection class:	IP54
Weight:	1.4 kg / 3.08 lbs
Voltage nom.	100-240V 50/60Hz
Voltage range	90-150/180-270 V
Max. current:	4,2 A (230 V) / 8,4 A (115 V)
LRA (Locked Rotor Amperage):	1,2 A
Cable length:	680 mm
Compressor speed range:	2000-4500 rpm
Housing plastic:	UL94-5VA

Controller dimensions:

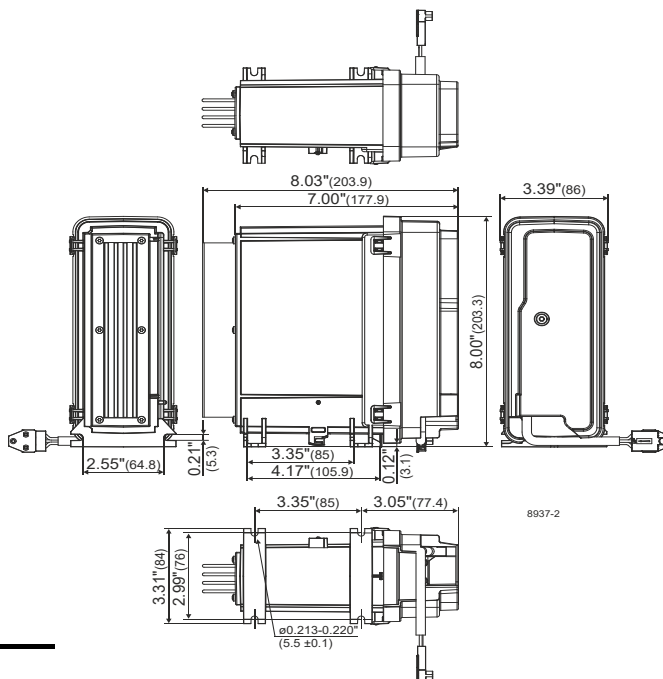

QR Code and Hyperlink leads to the [Operating Instructions.](#)

Operation Limits

Suctiongas temperature < +20°C (continuous operation)

System cooling

Ambient/ machineroom temperatures minimum /maximum

Ambient temperature range:	10 - 43°C / 50 - 110°F
Machine room temperature range compressor:	10 - 48°C / 50 - 119°F
Machine room temperature range controller:	10 - 50°C / 50 - 122°F

Compressor and Controller Cooling: Fan cooling 3m/s

Ensure proper airflow of 3 m/s at both compressor and electronic units.

The airflow for the electronics must be directed to the heat sink.

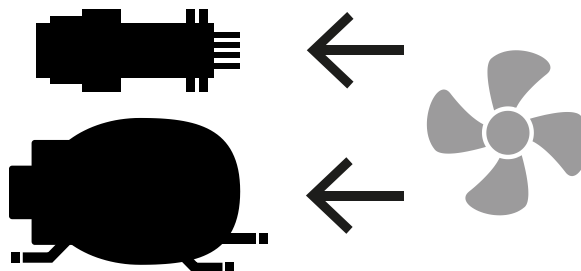

Operation pressure range

R290

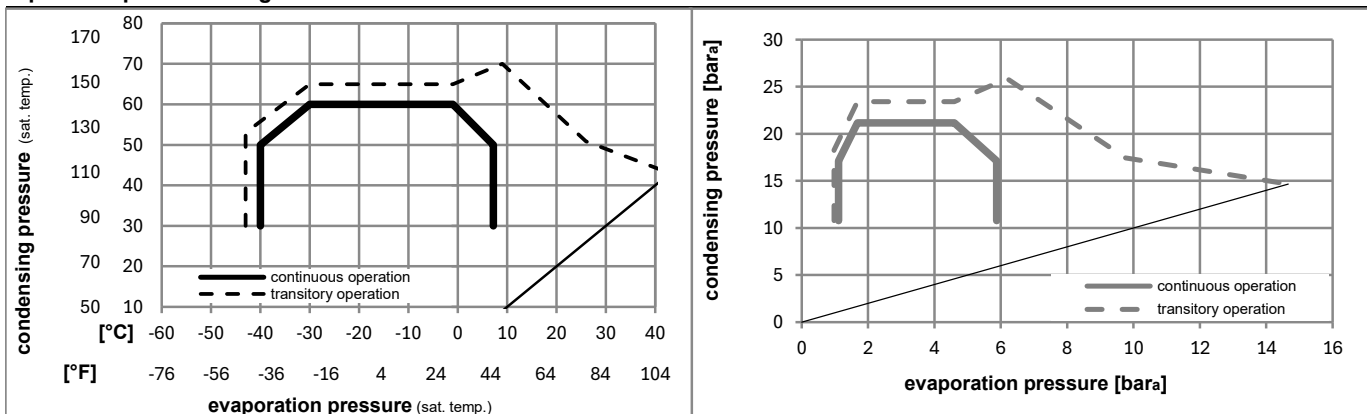

Model

Designation **NLV8.0CN** **100-240V 50/60Hz** **Conf. 2** Sales code: **105H7808**

Controller **NLV MP MV** **105N4960**

Controller connections

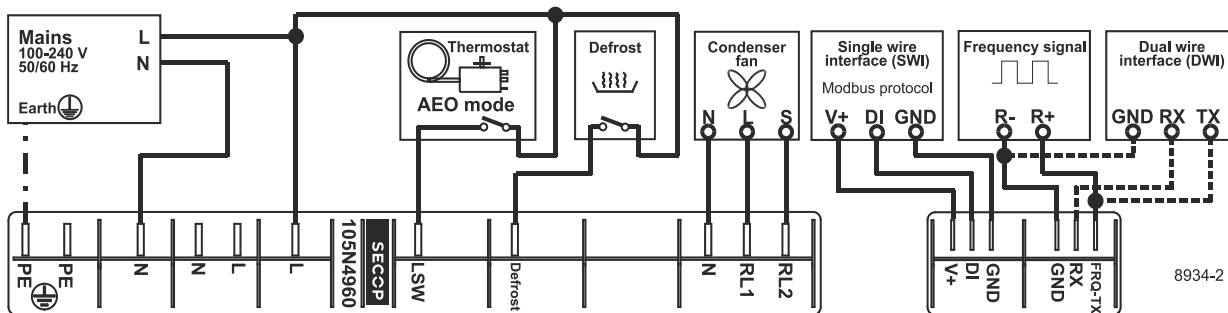
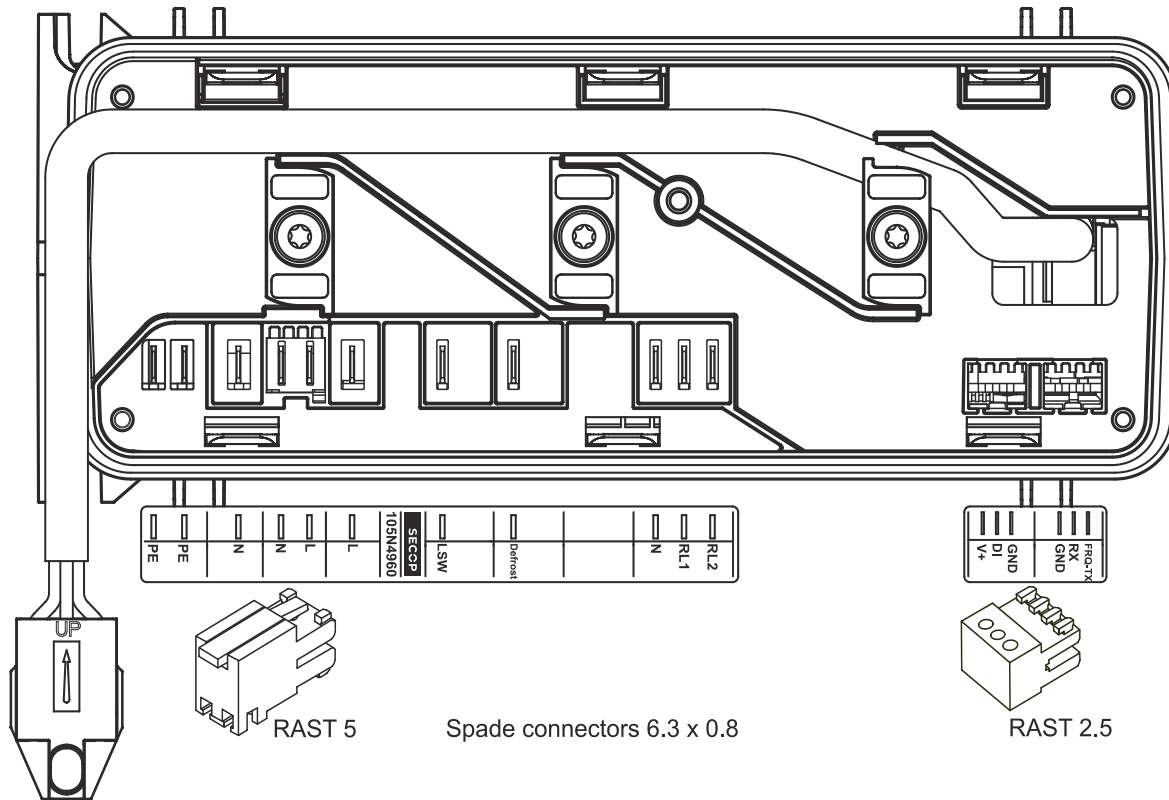

Accessories (Compressor + Controller) - check operation manual for details

103N2008	plastic cover	1 pcs
103N9110	plastic cover (MP of 103N2008)	80 pcs

Model

Designation	NLV8.0CN	100-240V 50/60Hz	Conf. 2	Sales code:	105H7808
Controller	NLV MP MV				105N4960

Optimization + standard conditions

R290, 220V, 50Hz, Rpm_N 4500, fan 3m/s

	Evaporating pressure (saturation temperature)				Condensing pressure (saturation temperature)						Power consumption			ASHRAE LBP
	pe	pc	RGT	Tliq	Cooling capacity			COP	EER	P1	I	Ref. mass flow		
	[°C]	[°C]	[°C]	[°C]	[W]	[Btu/h]	[kcal/h]	[W/W]	[Btu/Wh]	[kcal/Wh]	[W]	[A]	[kg/h]	
	-23	54	32	32	556,7	1901	479,1	1,72	5,87	1,48	323,9	1,72	5,64	ASHRAE LBP
	[°F]	-10	130	90	90									
	-25	55	32	55	414,7	1416	356,9	1,33	4,55	1,15	311,4	1,65	5,16	cecomaf LBP
	[°F]	-13	131	90	131									
	-35	40	20	40	316,3	1080	272,2	1,40	4,78	1,20	226,0	0,96	3,61	EN12900 LBP
	[°F]	-31	104	68	104									
	-7	54	35	46	1050,0	3586	903,6	2,29	7,82	1,97	458,3	2,42	11,98	ASHRAE MBP
	[°F]	20	130	95	115									
	-10	55	32	55	826,8	2824	711,6	1,91	6,51	1,64	433,6	2,27	10,46	cecomaf MBP
	[°F]	14	131	90	131									
	-10	45	20	45	940,6	3212	809,5	2,29	7,82	1,97	410,6	2,11	11,55	EN12900 MBP
	[°F]	14	113	68	113									

Standard conditions with different RPM

R290, 220V, 50Hz, fan 3m/s

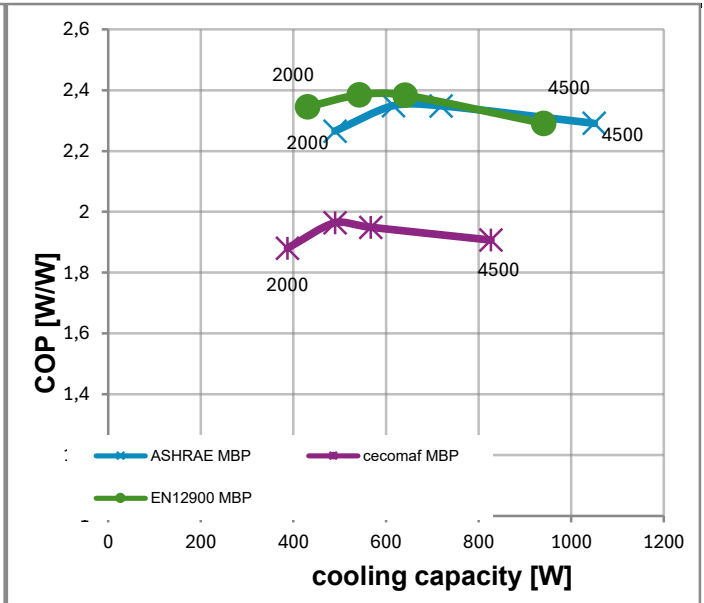
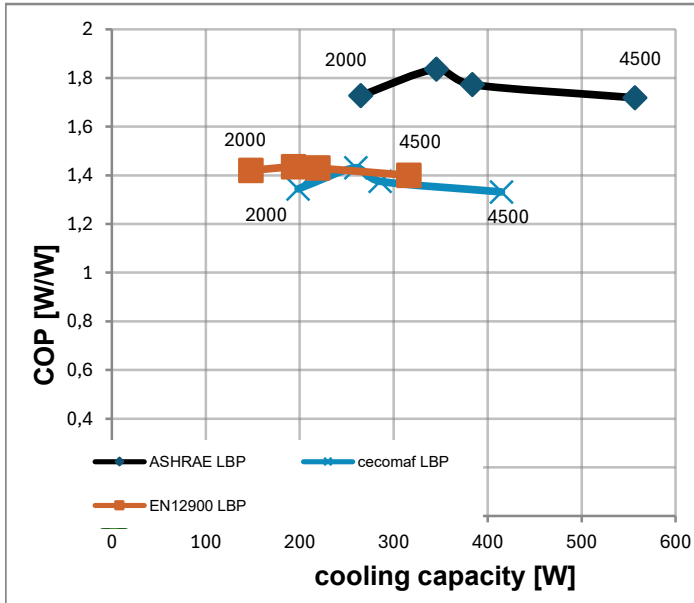

Test conditions:

	pe [°C]	pc [°C]	Tliq [°C]	Tsuc [°C]		pe [°C]	pc [°C]	Tliq [°C]	Tsuc [°C]
ASHRAE LBP	-23,33	54,44	32,22	32,22	ASHRAE MBP	-6,66	54,44	46,11	35
cecomaf LBP	-25	55	55	32	cecomaf MBP	-10	55	55	32
EN12900 LBP	-35	40	40	20	EN12900 MBP	-10	45	45	20

Model

Designation **NLV8.0CN** **100-240V 50/60Hz** **Conf. 3** Sales code: **105H7808**

Controller **NLV MP MV GFCI** **105N4962**

Sales code single: 105N4962 (1 units)
 Sales code industry pack: 105N4963 (8 units)
 Adaption to compressor: detached
 Protection class: IP54
 Weight: 1.4 kg / 3.08 lbs
 Voltage nom.: 100-240V 50/60Hz
 Voltage range: 90-150/180-270 V
 Max. current: 4,2 A (230 V) / 8,4 A (115 V)
 LRA (Locked Rotor Amperage): 1,2 A
 Cable length: 915 mm
 Compressor speed range: 2000-4500 rpm
 Housing plastic: UL94-5VA

Controller dimensions:

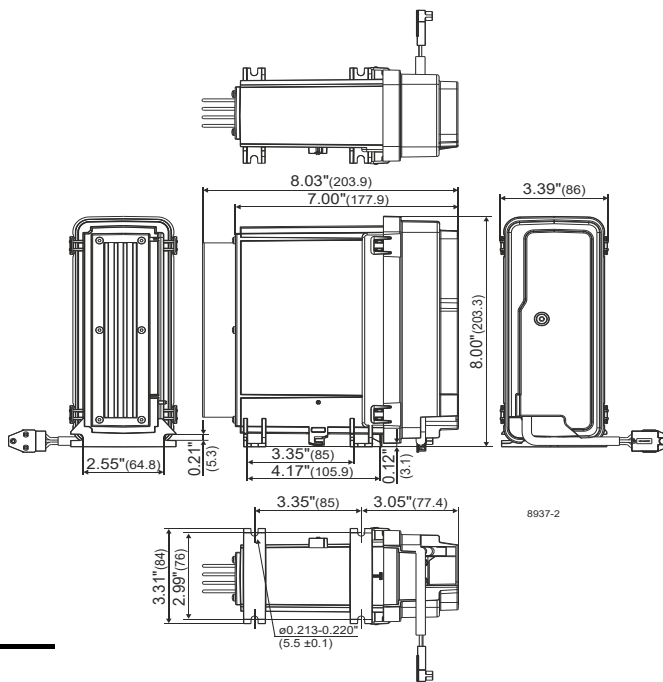

QR Code and Hyperlink leads to the [Operating Instructions.](#)

Operation Limits

Suctiongas temperature < +20°C (continuous operation)

System cooling

Ambient/ machineroom temperatures minimum /maximum

Ambient temperature range: 10 - 43°C / 50 - 110°F
 Machine room temperature range compressor: 10 - 48°C / 50 - 119°F
 Machine room temperature range controller: 10 - 50°C / 50 - 122°F

Compressor and Controller Cooling: Fan cooling 3m/s

Ensure proper airflow of 3 m/s at both compressor and electronic units.

The airflow for the electronics must be directed to the heat sink.

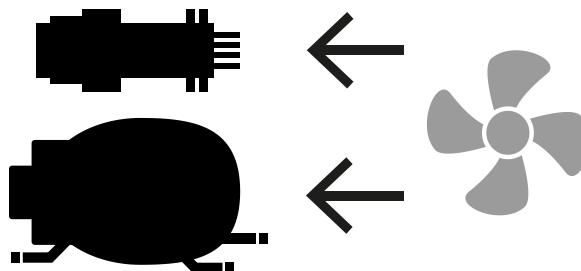

Operation pressure range

R290

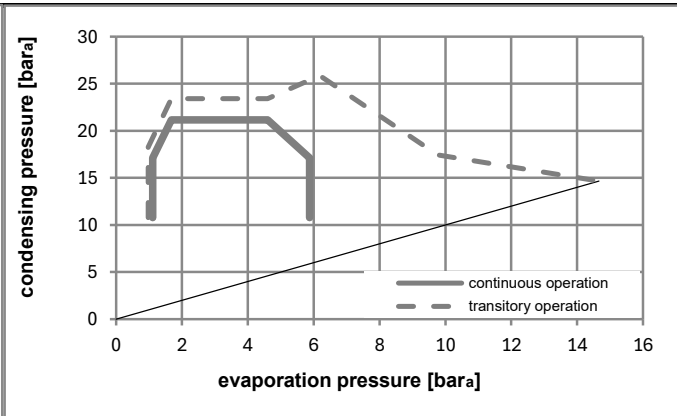
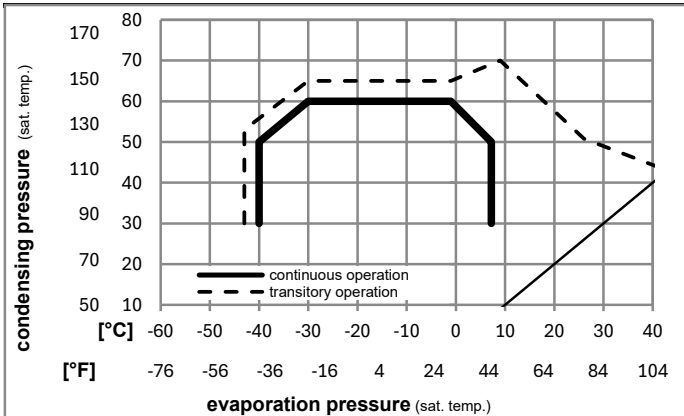

Model

Designation	NLV8.0CN	100-240V 50/60Hz	Conf. 3	Sales code:	105H7808
-------------	----------	------------------	---------	-------------	----------

Controller	NLV MP MV GFCI	105N4962
------------	----------------	----------

Controller connections

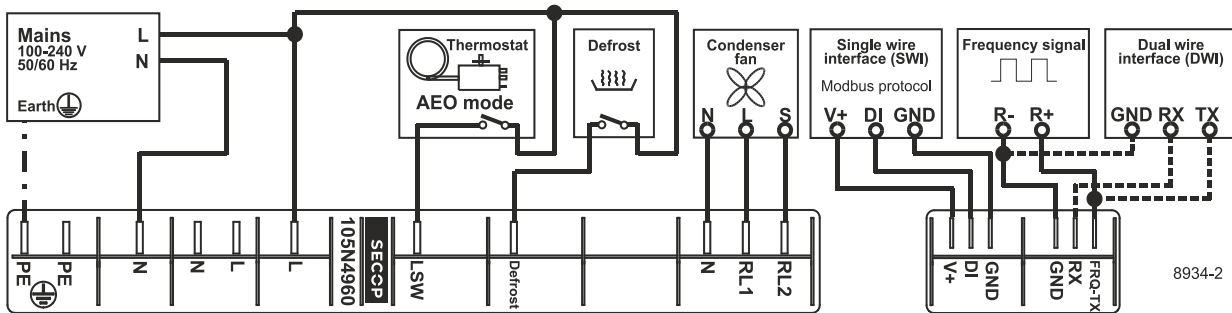
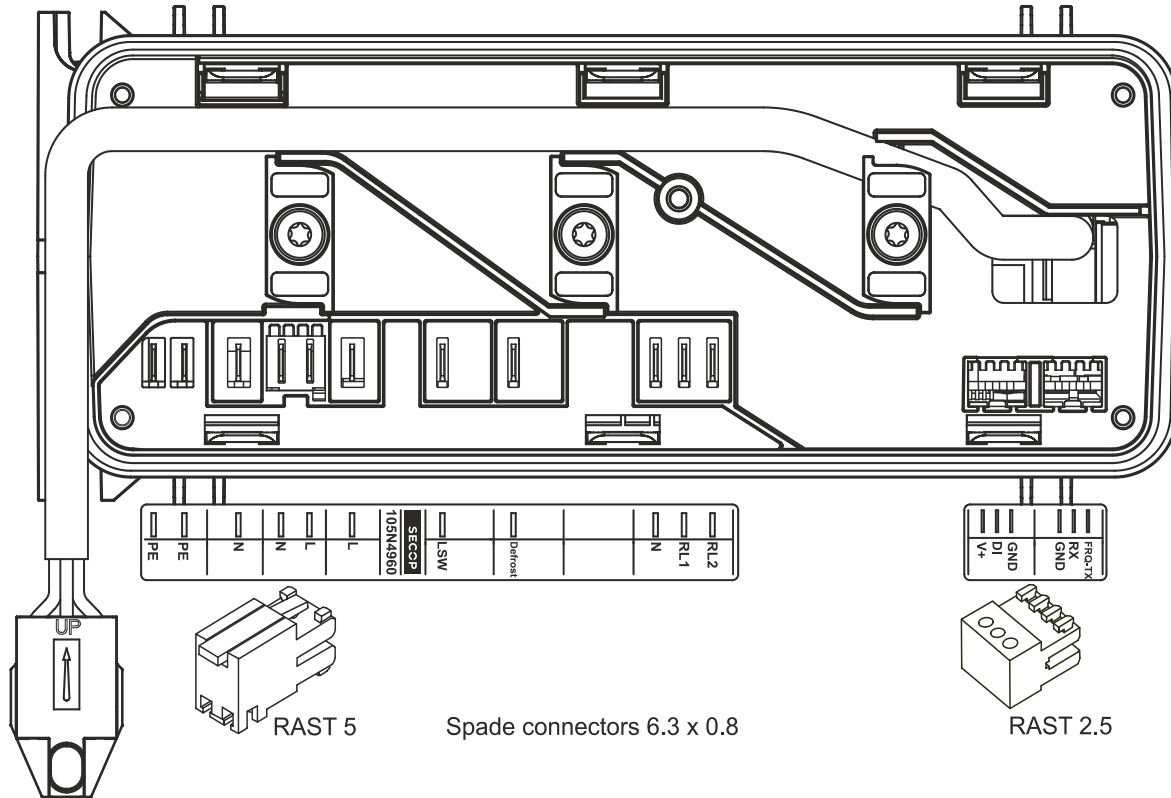

Accessories (Compressor + Controller) - check operation manual for details

103N2008	plastic cover	1 pcs
103N9110	plastic cover (MP of 103N2008)	80 pcs

Model

Designation **NLV8.0CN** **100-240V 50/60Hz** **Conf. 3** Sales code: **105H7808**

Controller **NLV MP MV GFCI** **105N4962**

Optimization + standard conditions

R290, 220V, 50Hz, Rpm_N 4500, fan 3m/s

	Evaporating pressure (saturation temperature)				Condensing pressure (saturation temperature)						Power consumption			ASHRAE LBP
	pe	pc	RGT	Tliq	Return gas temp.			Liquid temp.			COP	EER	P1	
	[°C]	[°C]	[°C]	[°C]	[W]	[Btu/h]	[kcal/h]	[W/W]	[Btu/Wh]	[kcal/Wh]	[W]	[A]	[kg/h]	
	-23	54	32	32	556,7	1901	479,1	1,72	5,87	1,48	323,9	1,72	5,64	ASHRAE LBP
	[°F]	-10	130	90	90									
	-25	55	32	55	414,7	1416	356,9	1,33	4,55	1,15	311,4	1,65	5,16	cecomaf LBP
	[°F]	-13	131	90	131									
	-35	40	20	40	316,3	1080	272,2	1,40	4,78	1,20	226,0	0,96	3,61	EN12900 LBP
	[°F]	-31	104	68	104									
	-7	54	35	46	1050,0	3586	903,6	2,29	7,82	1,97	458,3	2,42	11,98	ASHRAE MBP
	[°F]	20	130	95	115									
	-10	55	32	55	826,8	2824	711,6	1,91	6,51	1,64	433,6	2,27	10,46	cecomaf MBP
	[°F]	14	131	90	131									
	-10	45	20	45	940,6	3212	809,5	2,29	7,82	1,97	410,6	2,11	11,55	EN12900 MBP
	[°F]	14	113	68	113									

Standard conditions with different RPM

R290, 220V, 50Hz, fan 3m/s

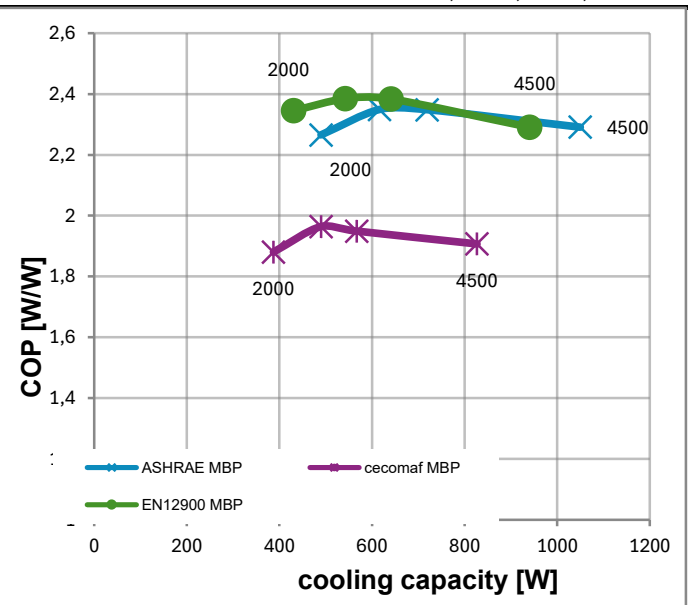
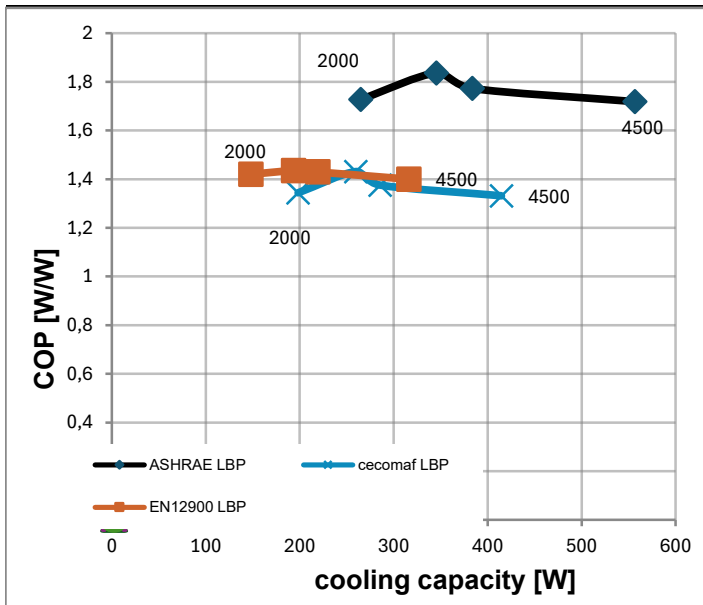

Test conditions:	pe [°C]	pc [°C]	Tliq [°C]	Tsuc [°C]	pe [°C]	pc [°C]	Tliq [°C]	Tsuc [°C]	
ASHRAE LBP	-23,33	54,44	32,22	32,22	ASHRAE MBP	-6,66	54,44	46,11	35
cecomaf LBP	-25	55	55	32	cecomaf MBP	-10	55	55	32
EN12900 LBP	-35	40	40	20	EN12900 MBP	-10	45	45	20

Model

Designation	NLV8.0CN	100-240V 50/60Hz1~ AC	Conf. 4	Sales code:	105H7808
Controller	NLV XT MV				105N4866

Sales code single:	105N4866 (1 units)
Sales code industry pack:	105N4867 (8 units)
Adaption to compressor:	detached
Protection class:	IP43
Weight:	1.5 kg / 3.3 lbs
Voltage nom.	100-240V 50/60Hz1~ AC
Voltage range	90-150/180-270 V
Max. current:	4,2 A (230 V) / 8,4 A (115 V)
LRA (Locked Rotor Amperage):	1,2 A
Cable length:	630 mm
Compressor speed range:	2000-4500 rpm
Housing plastic:	UL94-5VA

Controller dimensions:

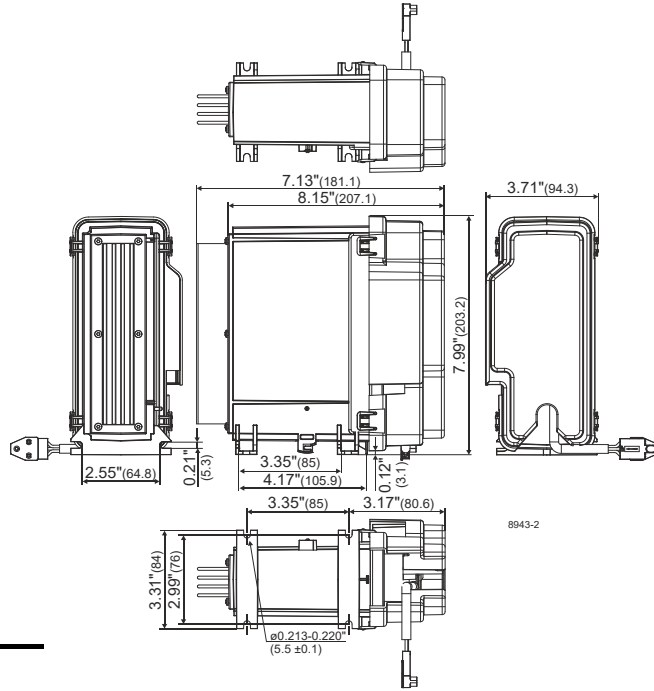

QR Code and Hyperlink leads to the [Operating Instructions.](#)

Operation Limits

Suctiongas temperature < +20°C (continuous operation)

System cooling

Ambient/ machineroom temperatures minimum /maximum

Ambient temperature range:	10 - 43°C / 50 - 110°F
Machine room temperature range compressor:	10 - 48°C / 50 - 119°F
Machine room temperature range controller:	10 - 50°C / 50 - 122°F

Compressor and Controller Cooling: Fan cooling 3m/s

Ensure proper airflow of 3 m/s at both compressor and electronic units.

The airflow for the electronics must be directed to the heat sink.

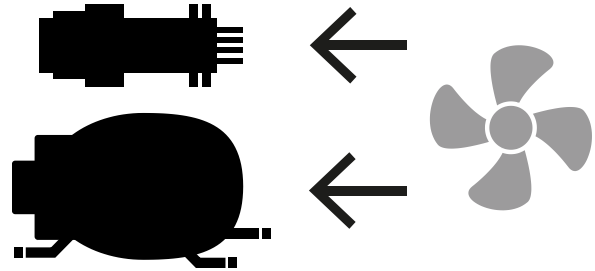

Operation pressure range

R290

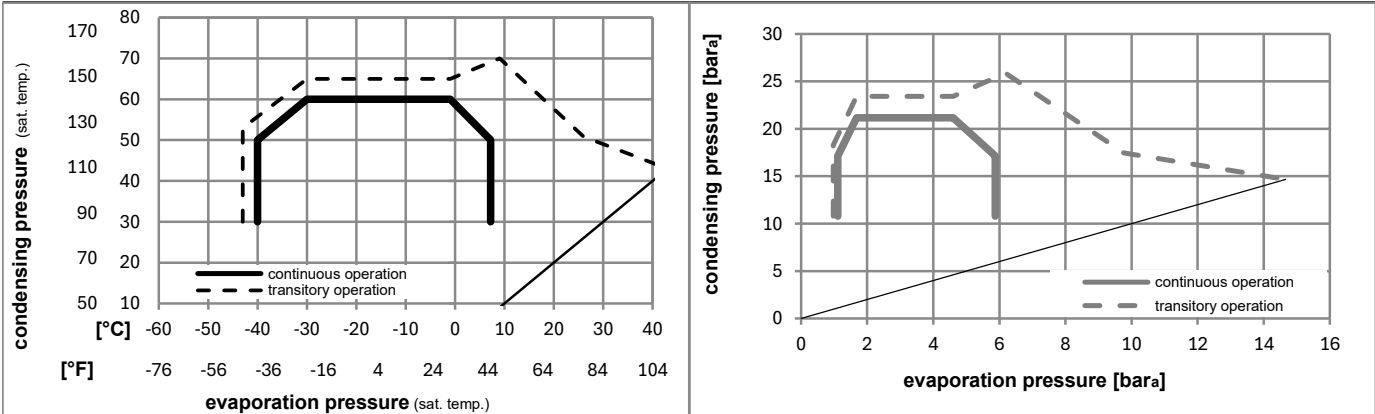

Model

Designation **NLV8.0CN** **100-240V 50/60Hz1~ AC** **Conf. 4** Sales code: **105H7808**

Controller **NLV XT MV** **105N4866**

Controller connections

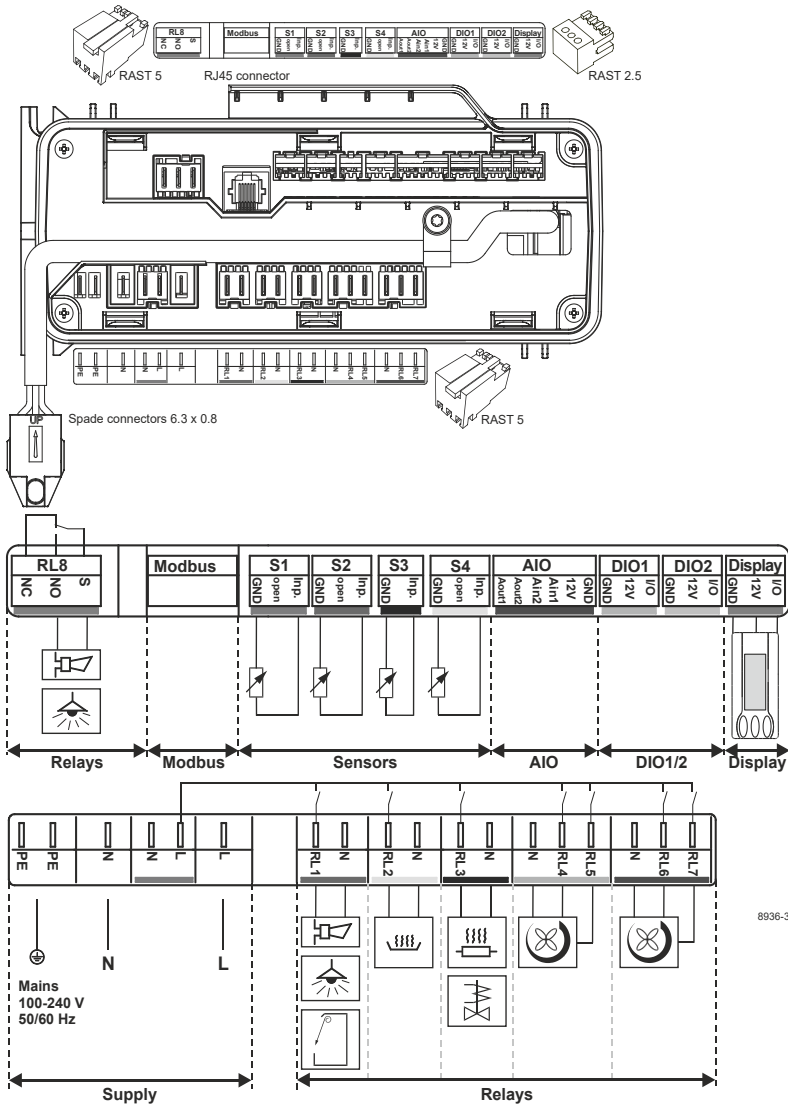

Accessories (Compressor + Controller) - check operation manual for details

103N2008	plastic cover	1 pcs
103N9110	plastic cover (MP of 103N2008)	80 pcs

Model

Designation	NLV8.0CN	100-240V 50/60Hz1~ AC	Conf. 4	Sales code:	105H7808
Controller	NLV XT MV				105N4866

Optimization + standard conditions

R290, 220V, 50Hz, Rpm_N 4500, fan 3m/s

	Evaporating pressure (saturation temperature)				Condensing pressure (saturation temperature)						Power consumption			ASHRAE LBP	
	pe	pc	RGT	Tliq	Return gas temp.			Liquid temp.			Cooling capacity	COP	EER		P1
	[°C]	[°F]	[°C]	[°F]	[W]	[Btu/h]	[kcal/h]	[W/W]	[Btu/Wh]	[kcal/Wh]	[W]	[A]	[kg/h]		
	-23	54	32	32	556,7	1901	479,1	1,72	5,87	1,48	323,9	1,72	5,64	ASHRAE LBP	
	-10	130	90	90											
	-25	55	32	55	414,7	1416	356,9	1,33	4,55	1,15	311,4	1,65	5,16	cecomaf LBP	
	-13	131	90	131											
	-35	40	20	40	316,3	1080	272,2	1,40	4,78	1,20	226,0	0,96	3,61	EN12900 LBP	
	-31	104	68	104											
	-7	54	35	46	1050,0	3586	903,6	2,29	7,82	1,97	458,3	2,42	11,98	ASHRAE MBP	
	20	130	95	115											
	-10	55	32	55	826,8	2824	711,6	1,91	6,51	1,64	433,6	2,27	10,46	cecomaf MBP	
	14	131	90	131											
	-10	45	20	45	940,6	3212	809,5	2,29	7,82	1,97	410,6	2,11	11,55	EN12900 MBP	
	14	113	68	113											

Standard conditions with different RPM

R290, 220V, 50Hz, fan 3m/s

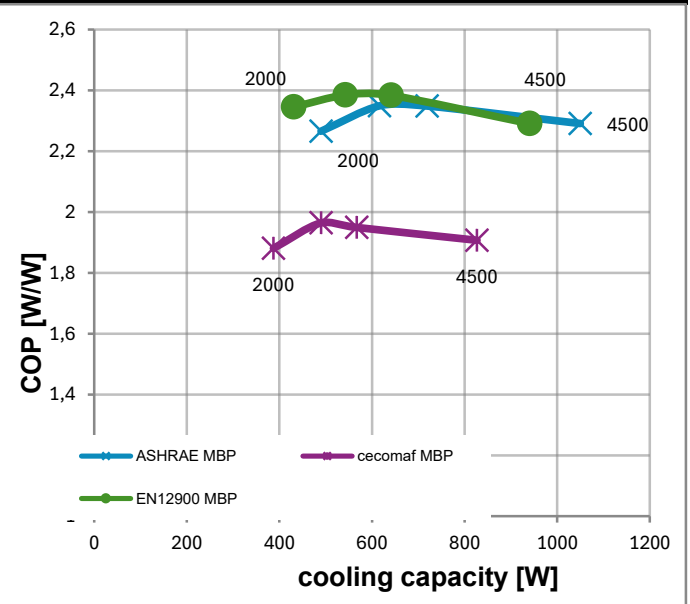
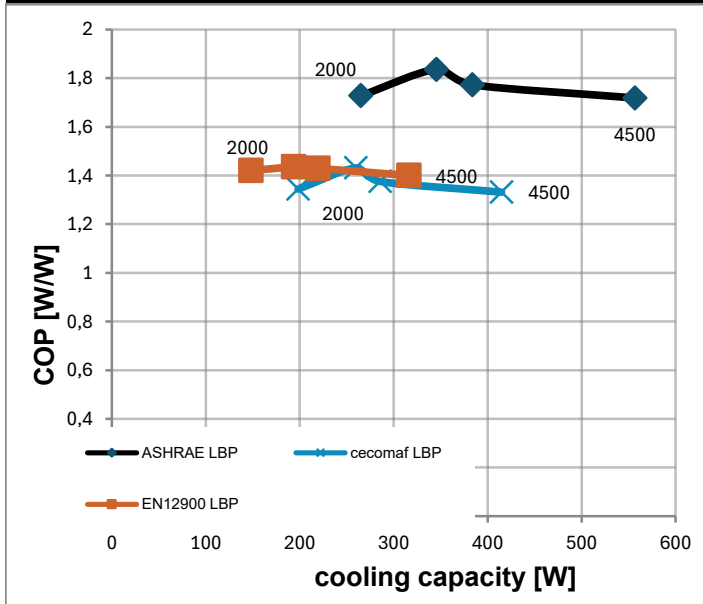

Test conditions:	pe [°C]	pc [°C]	Tliq [°C]	Tsuc [°C]	pe [°C]	pc [°C]	Tliq [°C]	Tsuc [°C]	
ASHRAE LBP	-23,33	54,44	32,22	32,22	ASHRAE MBP	-6,66	54,44	46,11	35
cecomaf LBP	-25	55	55	32	cecomaf MBP	-10	55	55	32
EN12900 LBP	-35	40	40	20	EN12900 MBP	-10	45	45	20