

## Model

Designation	<b>SC10CL</b>	220-240V/50Hz 1~	Sales code:	<b>104L2523</b>
-------------	---------------	------------------	-------------	-----------------

## Compressor design

Oil type	Polyolester	Refrigerant(s)	<b>R404A, R452A, R507</b>
Oil viscosity	32cST	Displacement	10,29cm <sup>3</sup> / 0,63cu.in
Oil quantity	550cm <sup>3</sup> / 18,6fl.oz	Compressors on pallet	80
Refr. charge - tech. limit	1300g / 45,9oz		
Free gas volume comp.	1460cm <sup>3</sup> / 49,4fl.oz		
Weight	13,1kg / 28,9lbs		
Motor protection	1# internal		
Winding resistance main	6,9Ω (at 25°C)		
Winding resistance aux	11Ω (at 25°C)		
Max. winding temp.	125°C / 257°F		
Max. discharge temp.	130°C / 266°F		



## General - Configurations with SC10CL

	<b>Conf. 1</b>	<b>Conf. 2</b>
Motorconfiguration	CSIR	CSIR
Power supply (nominal)	220-240V/50Hz	220-240V/50Hz
Number of phases	1	1
Voltage range	198-254V	198-254V
Approvals	VDE, CCC, EAC	VDE, CCC
Starting torque	HST	HST
Note	- / -	

## Applications with SC10CL

	<b>Conf. 1</b>	<b>Conf. 2</b>
Refrigerant	R404A	R452A
Application	LBP	LBP
System cooling	fan 3m/s	fan 3m/s
Hot gas defrost	OK	OK
Long interval pull down	OK	OK

## Electrical data - Configurations with SC10CL

	<b>Conf. 1</b>	<b>Conf. 2</b>
Starting device type	relay	relay
Run capacitor	- / -	- / -
Start capacitor	80μF	80μF
LRA (locked rotor amps / 4s)	13A	13A
RLA (rated load amps / 1s)	2,5A	2,5A
Cut in current	17A	17A

## Model

Designation

**SC10CL**

220-240V/50Hz 1~

Sales code:

**104L2523**

## Compressor dimensions

Housing	A Height	209mm / 8,23in
	B Height	203mm / 7,99in
	C Length shell	218mm / 8,58in
	D Length w. cover	255mm / 10,04in
	E Width	151mm / 5,94in

Connectors		Suction	Discharge	Process
		X	Y	Z
Diameter	[mm]	øi 8,11-8,29	øi 6,11-6,29	øi 6,11-6,29
	(i:inside, o:outside) [in]	øi 0,32-0,33	øi 0,24-0,25	øi 0,24-0,25
Material		copper	copper	copper
Horizontal angle	±2°	37°	37°	143°
Vertical angle	±2°	30°	0°	150°
Position l/h/w	[mm]	107/183/55	115/100/63	-107/183/55
	[in]	4,2/7,2/2,2	4,5/3,9/2,5	-4,2/7,2/2,2
Straight tube l.	[mm]	12	12	12
	[in]	0,5	0,5	0,5

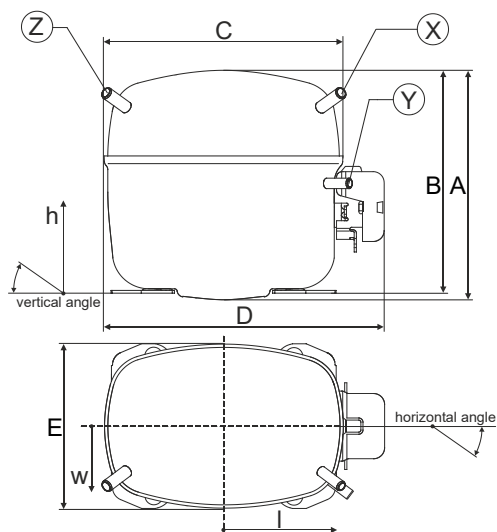

## Compressor fixation



### Bolt joint



### Snap-on

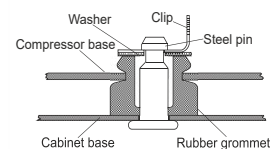

## Mounting accessories

	one comp.	multi pack
Bolt joint   M6   ø16mm	118-1917	118-1918
Bolt joint   ø1/4"   ø16mm	118-1946	
Bolt joint   ø1/4"   ø19mm	118-1949	
Snap-on   ø7,3   ø16mm	118-1947	118-1919

## Application notes

Provision for PE Grounding is located at the PE Stamp on the compressor

## Model

Designation	<b>SC10CL</b>	<b>220-240V/50Hz</b>	<b>Conf. 1</b>	Sales code:	<b>104L2523</b>
-------------	---------------	----------------------	----------------	-------------	-----------------

## Configuration

Motorconfiguration	CSIR
Power supply (nominal)	220-240V/50Hz 1~
Refrigerant	R404A
Application	LBP
Voltage range	198-254V
Starting torque	HST
Approvals	VDE CCC EAC

## Electrical accessories / wiring diagram

CSIR

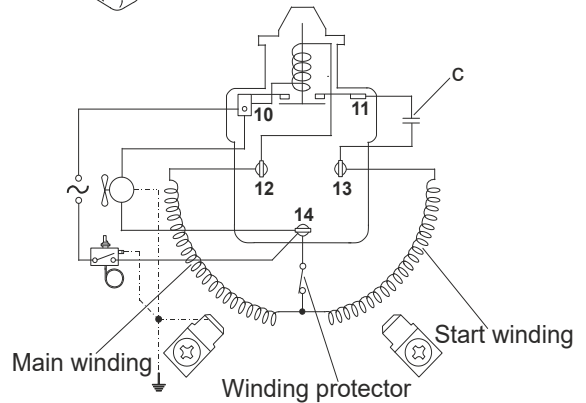
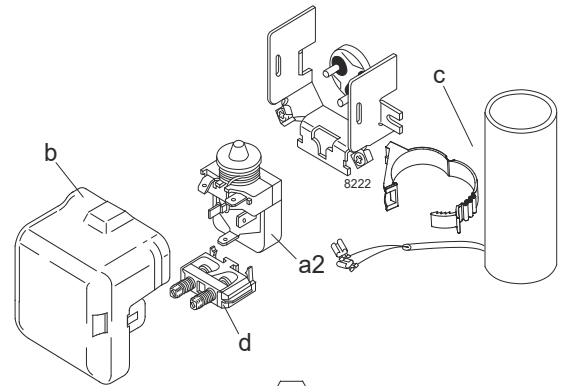

## Ambient/ machine room temperatures minimum /maximum

Ambient temperature range:	10 - 38°C / 50 - 101°F
Machine room temperature range:	10 - 43°C / 50 - 110°F
Compressor cooling:	fan 3m/s

## Operation Limits

### Operation pressure range

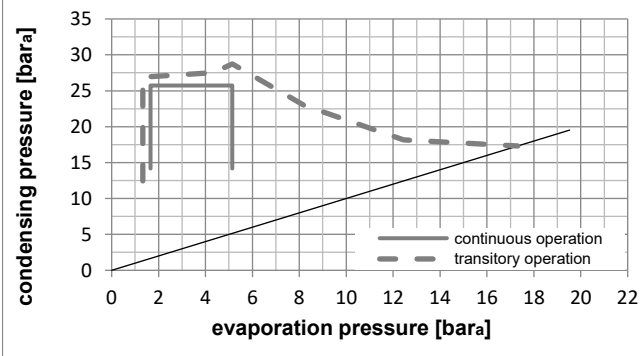
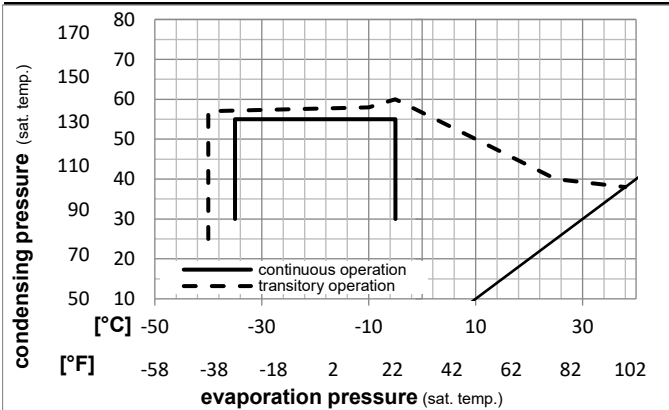

### Components

a2	assy. relay	117U6003
c	start capacitor (80μF)	117U5017
d	cord relief	103N1004
b	plastic cover	103N2009

### Model

Designation **SC10CL** **220-240V/50Hz** Conf. 1 Sales code: **104L2523**

### Optimization + standard conditions

R404A, 220V/50Hz, CSIR, fan 3m/s, VDE, CCC, EAC

		Evaporating pressure (saturation temperature)				Condensing pressure (saturation temperature)						Power consumption			
		Return gas temp.		Liquid temp.		Cooling capacity		COP	EER		P1	Current consumption		Ref. mass flow	
		pe	pc	RGT	Tliq	[W]	[Btu/h]	[kcal/h]	[W/W]	[Btu/Wh]	[kcal/Wh]	[W]	I	m	
[°C]	[°F]	[°C]	[°F]	[°C]	[°F]								[A]	[kg/h]	ASHRAE LBP
-23	-10	54	130	32	90	400,3	1367	344,5	1,13	3,85	0,97	355,2	2,28	9,33	ASHRAE LBP
-25	-13	55	131	32	90	261,4	893	225,0	0,79	2,69	0,68	332,5	2,21	8,17	cecomaf LBP
-35	-31	40	104	20	68	196,7	672	169,3	0,79	2,69	0,68	249,7	1,93	5,34	EN12900 LBP
-23	-10	49	120	4,4	40	312,1	1066	268,6	0,85	2,91	0,73	365,9	2,28	11,05	ARI540 LBP
-23	-10	41	105	32	90	498,0	1701	428,5	1,34	4,58	1,15	371,1	2,26	11,60	AHAM LBP
-35	-31	45	113	32	90	168,1	574	144,6	0,69	2,36	0,60	242,8	1,91	4,49	opt

### Performance tables

R404A, 220V/50Hz, CSIR, fan 3m/s, VDE, CCC, EAC

	pe		Cooling capacity			COP	EER		P1	I	m
	[°C]	[°F]	[W]	[Btu/h]	[kcal/h]	[W/W]	[Btu/Wh]	[kcal/Wh]	[W]	[A]	[kg/h]
[°C / °F]	-35	-31	168,1	574	144,6	0,69	2,36	0,60	242,8	1,91	4,49
cond. pressure	-30	-22	258,5	883	222,4	0,88	3,01	0,76	293,6	2,05	6,94
pc= 45/113	-25	-13	365,0	1246	314,1	1,04	3,56	0,90	350,3	2,22	9,84
return gas temp.	-23	-10	405,2	1384	348,7	1,09	3,74	0,94	370,4	2,27	10,95
RGT= 32/90	-20	-4	489,5	1672	421,3	1,19	4,07	1,03	410,3	2,39	13,28
liquid temp	-15	5	634,0	2165	545,6	1,35	4,60	1,16	470,9	2,59	17,32
Tliq= 45/113	-5	23	990,5	3383	852,5	1,70	5,79	1,46	584,2	3,04	27,54
[°C / °F]	-35	-31	95,3	326	82,0	0,42	1,45	0,36	225,0	1,84	2,95
cond. pressure	-30	-22	171,7	586	147,8	0,63	2,14	0,54	273,7	2,01	5,34
pc= 55/131	-25	-13	261,4	893	225,0	0,79	2,69	0,68	332,5	2,21	8,17
return gas temp	-23	-10	295,3	1009	254,2	0,83	2,85	0,72	354,3	2,28	9,25
RGT= 32/90	-20	-4	366,4	1251	315,4	0,92	3,14	0,79	398,8	2,42	11,53
liquid temp	-15	5	488,6	1669	420,5	1,04	3,55	0,89	470,1	2,64	15,49
Tliq= 55/131	-5	23	792,1	2705	681,7	1,28	4,38	1,10	617,3	3,15	25,64

## Model

Designation	<b>SC10CL</b>	<b>220-240V/50Hz</b>	<b>Conf. 2</b>	Sales code:	<b>104L2523</b>
-------------	---------------	----------------------	----------------	-------------	-----------------

## Configuration

Motorconfiguration	CSIR
Power supply (nominal)	220-240V/50Hz 1~
Refrigerant	R452A
Application	LBP
Voltage range	198-254V
Starting torque	HST
Approvals	VDE CCC

## Electrical accessories / wiring diagram

CSIR

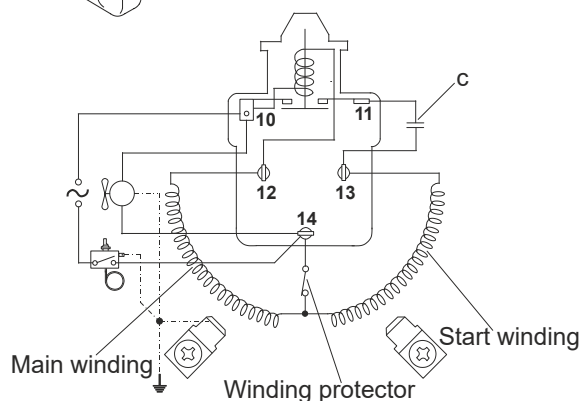
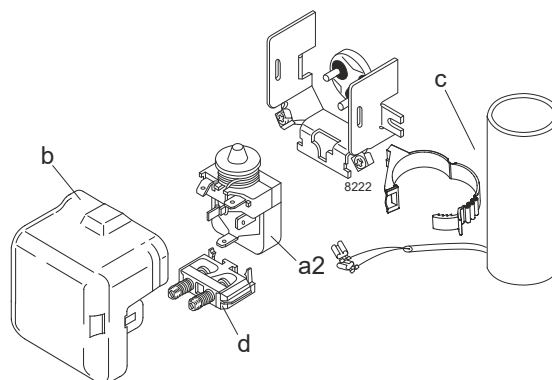

## Ambient/ machine room temperatures minimum /maximum

Ambient temperature range: 10 - 38°C / 50 - 101°F

Machine room temperature range: 10 - 43°C / 50 - 110°F

Compressor cooling: fan 3m/s

## Operation Limits

## Operation pressure range

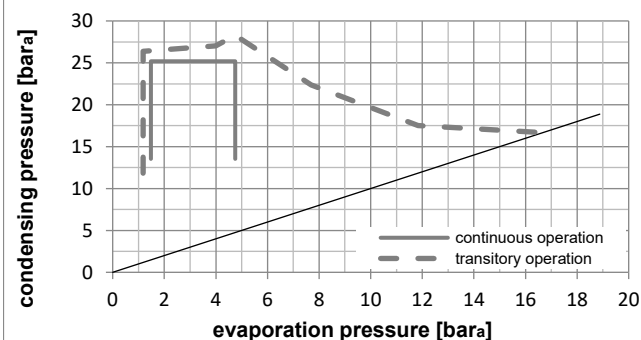
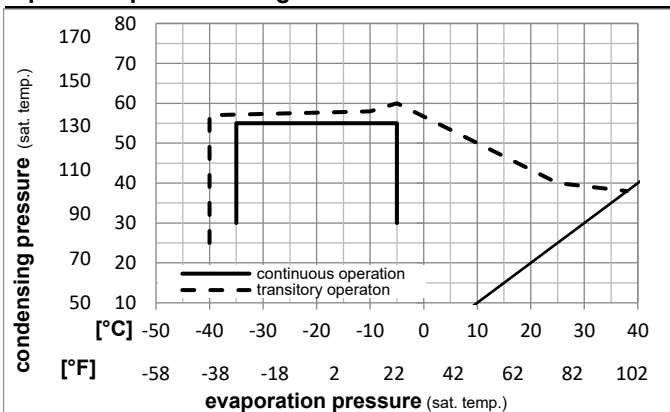

## Components

a2	assy. relay	117U6003
c	start capacitor (80μF)	117U5017
d	cord relief	103N1004
b	plastic cover	103N2009

### Model

Designation **SC10CL** **220-240V/50Hz** Conf. 2 Sales code: **104L2523**

### Optimization + standard conditions

R452A, 220V/50Hz, CSIR, fan 3m/s, VDE, CCC

	Evaporating pressure (saturation temperature)				Condensing pressure (saturation temperature)			Return gas temp.	Liquid temp.	Cooling capacity	COP	EER	Power consumption			ASHRAE LBP
	pe	pc	RGT	Tliq	[W]	[Btu/h]	[kcal/h]						P1	I	m	
[°C]	[°C]	[°C]	[°C]	[W]	[Btu/h]	[kcal/h]	[W/W]	[Btu/Wh]	[kcal/Wh]	[W]	[A]	[kg/h]				
[°C]	-23	54	32	32	365,2	1247	314,3	1,09	3,74	0,94	333,8	2,20	8,78	ASHRAE LBP		
[°F]	-10	130	90	90												
[°C]	-25	55	32	55	240,5	821	206,9	0,77	2,63	0,66	311,8	2,12	7,65	cecomaf LBP		
[°F]	-13	131	90	131												
[°C]	-35	40	20	40	177,0	604	152,3	0,76	2,60	0,65	232,9	1,85	4,94	EN12900 LBP		
[°F]	-31	104	68	104												
[°C]	-23	49	4,4	49	289,4	988	249,0	0,84	2,87	0,72	344,4	2,24	10,40	ARI540 LBP		
[°F]	-10	120	40	120												
[°C]	-23	41	32	32	457,6	1563	393,8	1,31	4,47	1,13	349,9	2,26	11,00	AHAM LBP		
[°F]	-10	105	90	90												
[°C]	-35	45	32	45	150,7	515	129,7	0,67	2,28	0,57	226,0	1,82	4,14	opt		
[°F]	-31	113	90	113												

### Performance tables

R452A, 220V/50Hz, CSIR, fan 3m/s, VDE, CCC

	pe		Cooling capacity			COP	EER		P1	I	m
	[°C]	[°F]	[W]	[Btu/h]	[kcal/h]	[W/W]	[Btu/Wh]	[kcal/Wh]	[W]	[A]	[kg/h]
[°C / °F]	-35	-31	150,7	515	129,7	0,67	2,28	0,57	226,0	1,82	4,14
cond. pressure	-30	-22	235,1	803	202,3	0,86	2,92	0,74	274,8	2,00	6,48
pc= 45/113	-25	-13	335,6	1146	288,8	1,02	3,48	0,88	329,5	2,19	9,28
return gas temp.	-23	-10	373,8	1276	321,7	1,07	3,66	0,92	349,0	2,26	10,36
RGT= 32/90	-20	-4	454,1	1551	390,8	1,17	4,00	1,01	387,7	2,39	12,63
liquid temp	-15	5	592,7	2024	510,1	1,33	4,53	1,14	447,2	2,60	16,58
Tliq= 45/113	-5	23	937,9	3203	807,1	1,67	5,72	1,44	560,2	2,99	26,65
[°C / °F]	-35	-31	84,7	289	72,9	0,41	1,39	0,35	208,4	1,76	2,67
cond. pressure	-30	-22	155,8	532	134,1	0,61	2,09	0,53	255,0	1,93	4,93
pc= 55/131	-25	-13	240,5	821	206,9	0,77	2,63	0,66	311,8	2,12	7,65
return gas temp	-23	-10	272,7	931	234,7	0,82	2,80	0,70	332,9	2,20	8,69
RGT= 32/90	-20	-4	340,7	1163	293,2	0,91	3,09	0,78	376,2	2,35	10,90
liquid temp	-15	5	458,4	1565	394,5	1,03	3,51	0,88	446,0	2,59	14,78
Tliq= 55/131	-5	23	754,2	2576	649,1	1,27	4,35	1,10	592,0	3,11	24,75