

## Model

Designation	<b>SC10DL</b>	<b>220-240V/50Hz 1~</b>	Sales code:	<b>104L2535</b>
-------------	---------------	-------------------------	-------------	-----------------

## Compressor design

Oil type	Polyolester	Refrigerant(s)	<b>R404A, R507, R407C</b>
Oil viscosity	32cST	Displacement	10,29cm <sup>3</sup> / 0,63cu.in
Oil quantity	550cm <sup>3</sup> / 18,6fl.oz	Compressors on pallet	80
Refr. charge - tech. limit	1300g / 45,9oz		
Free gas volume comp.	1410cm <sup>3</sup> / 47,7fl.oz		
Weight	13,2kg / 29,1lbs		
Motor protection	1# internal		
Winding resistance main	5,13Ω (at 25°C)		
Winding resistance aux	13,51Ω (at 25°C)		
Max. winding temp.	125°C / 257°F		
Max. discharge temp.	130°C / 266°F		



## General - Configurations with SC10DL

### Conf. 1

Motorconfiguration	CSIR
Power supply (nominal)	220-240V/50Hz
Number of phases	1
Voltage range	198-254V
Approvals	VDE, CCC
Starting torque	HST
Note	- / -

## Applications with SC10DL

### Conf. 1

Refrigerant	R404A
Application	HBP
System cooling	fan 3m/s
Hot gas defrost	OK
Long interval pull down	OK

## Electrical data - Configurations with SC10DL

### Conf. 1

Starting device type	relay
Run capacitor	-/-
Start capacitor	80μF
LRA (locked rotor amps / 4s)	16,2A
RLA (rated load amps / 1s)	3,1A
Cut in current	16,2A

## Model

Designation	<b>SC10DL</b>	<b>220-240V/50Hz 1~</b>	Sales code:	<b>104L2535</b>
-------------	---------------	-------------------------	-------------	-----------------

## Compressor dimensions

<b>Housing</b>	A Height	209mm / 8,23in
	B Height	203mm / 7,99in
	C Length shell	218mm / 8,58in
	D Length w. cover	255mm / 10,04in
	E Width	151mm / 5,94in

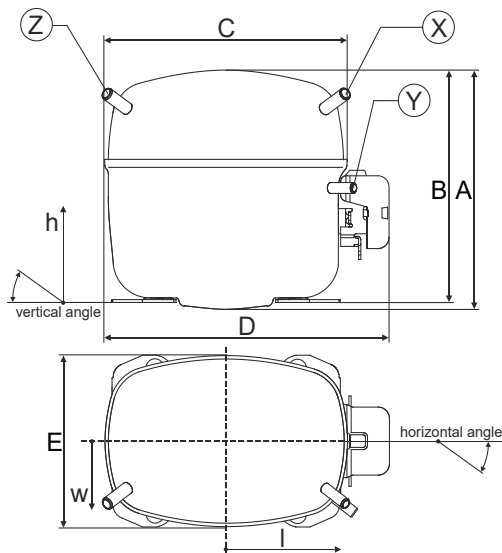

Connectors		Suction	Discharge	Process
		X	Y	Z
Diameter	[mm]	øi 8,11-8,29	øi 6,11-6,29	øi 6,11-6,29
(i:inside, o:outside)	[in]	øi 0,32-0,33	øi 0,24-0,25	øi 0,24-0,25
Material		copper	copper	copper
Horizontal angle	±2°	37°	37°	143°
Vertical angle	±2°	30°	0°	150°
Position l/h/w	[mm]	107/183/55	115/100/63	-107/183/55
	[in]	4,2/7,2/2,2	4,5/3,9/2,5	-4,2/7,2/2,2
Straight tube l.	[mm]	12	12	12
	[in]	0,5	0,5	0,5

## Compressor fixation

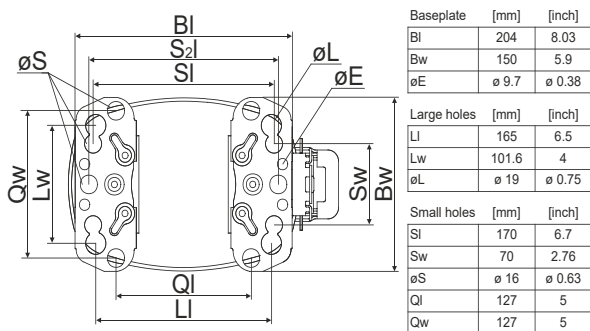

## Bolt joint

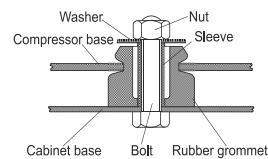

## Snap-on

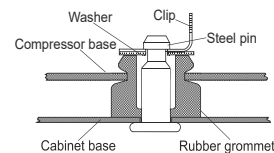

Mounting accessories	one comp.	multi pack
Bolt joint   M6   ø16mm	118-1917	118-1918
Bolt joint   ø1/4"   ø16mm	118-1946	
Bolt joint   ø1/4"   ø19mm	118-1949	
Snap-on   ø7,3   ø16mm	118-1947	118-1919

## Application notes

Provision for PE Grounding is located at the PE Stamp on the compressor

### Model

Designation	<b>SC10DL</b>	<b>220-240V/50Hz</b>	Conf. 1	Sales code:	<b>104L2535</b>
-------------	---------------	----------------------	---------	-------------	-----------------

### Configuration

Motorconfiguration	CSIR
Power supply (nominal)	220-240V/50Hz 1~
Refrigerant	R404A
Application	HBP
Voltage range	198-254V
Starting torque	HST
Approvals	VDE CCC

### Electrical accessories / wiring diagram

CSIR

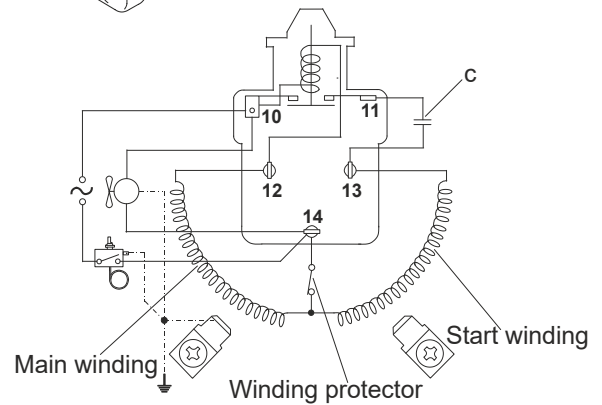
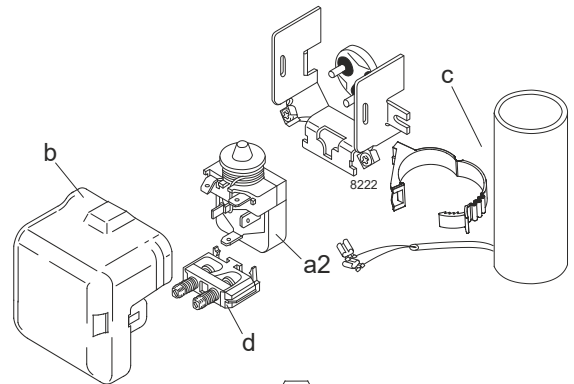

### Ambient/ machine room temperatures minimum /maximum

Ambient temperature range: 10 - 38°C / 50 - 101°F

Machine room temperature range: 10 - 43°C / 50 - 110°F

Compressor cooling: fan 3m/s

### Operation Limits

### Operation pressure range

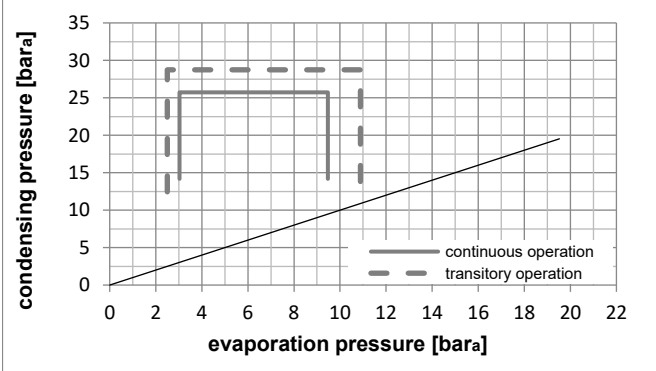
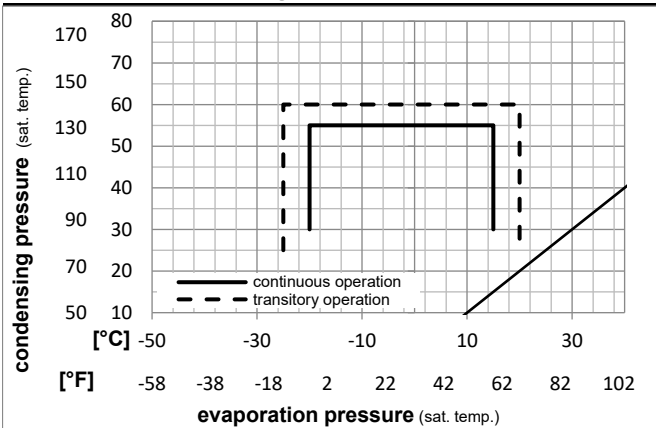

### Components

a2	relay	117U6005
c	start capacitor (80µF)	117U5017
d	cord relief	103N1004
b	plastic cover	103N2009

## Model

Designation **SC10DL** **220-240V/50Hz** Conf. 1 Sales code: **104L2535**

## Optimization + standard conditions

R404A, 220V/50Hz, CSIR, fan 3m/s, VDE, CCC

Evaporating pressure (saturation temperature)				Condensing pressure (saturation temperature)			Return gas temp.			Liquid temp.			Cooling capacity			COP	EER	Power consumption			Ref. mass flow m	ASHRAE HBP
pe	pc	RGT	Tliq	[W]	[Btu/h]	[kcal/h]	[W/W]	[Btu/Wh]	[kcal/Wh]	P1	I	[kg/h]										
[°C]	[°C]	[°C]	[°C]	[W]	[Btu/h]	[kcal/h]	[W/W]	[Btu/Wh]	[kcal/Wh]	[W]	[A]	[kg/h]										
7,2	54	35	46	1478,2	5048	1272,2	2,15	7,35	1,85	686,7	3,80	42,03										
[°F]																						
45	130	95	115																			
5	55	32	55	1156,0	3948	994,8	1,71	5,85	1,47	674,9	3,74	38,50										
[°C]																						
[°F]																						
41	131	90	131																			
5	50	20	50	1208,0	4126	1039,6	1,92	6,56	1,65	628,6	3,57	41,20										
[°C]																						
[°F]																						
41	122	68	122																			
-7	54	35	46	838,2	2862	721,3	1,51	5,16	1,30	554,9	3,27	23,06										
[°C]																						
[°F]																						
20	130	95	115																			
-10	55	32	55	613,6	2096	528,1	1,19	4,05	1,02	517,8	3,12	19,64										
[°C]																						
[°F]																						
14	131	90	131																			
-10	45	20	45	730,5	2495	628,7	1,53	5,21	1,31	478,5	2,97	22,00										
[°C]																						
[°F]																						
14	113	68	113																			

## Performance tables

R404A, 220V/50Hz, CSIR, fan 3m/s, VDE, CCC

	pe		Cooling capacity			COP	EER		P1	I	m
	[°C]	[°F]	[W]	[Btu/h]	[kcal/h]	[W/W]	[Btu/Wh]	[kcal/Wh]	[W]	[A]	[kg/h]
[°C / °F]	-20	-4	471,3	1610	405,6	1,26	4,31	1,09	373,4	2,55	12,79
cond. pressure	-15	5	610,8	2086	525,7	1,42	4,86	1,23	428,9	2,78	16,69
pc= 45/113	-10	14	775,2	2648	667,2	1,62	5,53	1,39	478,5	2,97	21,35
return gas temp.	-5	23	967,8	3305	832,9	1,85	6,33	1,60	522,0	3,15	26,91
RGT= 32/90	0	32	1191,8	4070	1025,6	2,13	7,28	1,83	559,2	3,30	33,50
liquid temp	5	41	1450,4	4953	1248,2	2,46	8,40	2,12	589,9	3,42	41,32
Tliq= 45/113	15	59	2084,9	7120	1794,3	3,30	11,28	2,84	631,1	3,61	61,48
[°C / °F]	-20	-4	349,8	1195	301,0	0,92	3,15	0,79	378,8	2,59	11,01
cond. pressure	-15	5	474,1	1619	408,0	1,05	3,59	0,90	451,6	2,87	15,04
pc= 55/131	-10	14	613,6	2096	528,1	1,19	4,05	1,02	517,8	3,12	19,64
return gas temp	-5	23	771,6	2635	664,0	1,34	4,57	1,15	577,2	3,35	24,97
RGT= 32/90	0	32	951,2	3249	818,7	1,51	5,16	1,30	629,6	3,56	31,19
liquid temp	5	41	1156,0	3948	994,8	1,71	5,85	1,47	674,9	3,74	38,50
Tliq= 55/131	15	59	1653,5	5647	1423,0	2,22	7,60	1,91	743,4	4,04	57,34