

Model

Designation	SC10GH	220-240V/50Hz 1~ 208-230V/60Hz 1~	Sales code:	104G8041
-------------	---------------	-----------------------------------	-------------	-----------------

Compressor design

Oil type	Polyolester	Refrigerant(s)	R134a, R513A
Oil viscosity	22cST	Displacement	10,29cm ³ / 0,63cu.in
Oil quantity	504cm ³ / 17fl.oz	Compressors on pallet	80
Refr. charge - tech. limit	1300g / 45,9oz		
Free gas volume comp.	1510cm ³ / 51,1fl.oz		
Weight	12,8kg / 28,2lbs		
Motor protection	1# internal		
Winding resistance main	5,13Ω (at 25°C)		
Winding resistance aux	13,51Ω (at 25°C)		
Max. winding temp.	125°C / 257°F		
Max. discharge temp.	130°C / 266°F		



General - Configurations with SC10GH

	Conf. 1	Conf. 2	Conf. 3	Conf. 4
Motorconfiguration	CSIR	CSIR	CSIR	CSIR
Power supply (nominal)	220-240V/50Hz	220-240V/50Hz	208-230V/60Hz	208-230V/60Hz
Number of phases	1	1	1	1
Voltage range	198-254V	198-254V	198-254V	198-254V
Approvals	VDE, UL, CCC, KC	VDE, UL, CCC	VDE, UL, CCC, KC	VDE, UL, CCC
Starting torque	HST	HST	HST	HST
Note	- / -			

Applications with SC10GH

	Conf. 1	Conf. 2	Conf. 3	Conf. 4
Refrigerant	R134a	R513A	R134a	R513A
Application	HBP	HBP	HBP	HBP
System cooling	fan 3m/s	fan 3m/s	fan 3m/s	fan 3m/s
Hot gas defrost	OK	OK	OK	OK
Long interval pull down	OK	OK	OK	OK

Electrical data - Configurations with SC10GH

	Conf. 1	Conf. 2	Conf. 3	Conf. 4
Starting device type	relay	relay	relay	relay
Run capacitor	- / -	- / -	- / -	- / -
Start capacitor	80μF	80μF	80μF	80μF
LRA (locked rotor amps / 4s)	16,2A	16,2A	15,6A	15,6A
RLA (rated load amps / 1s)	3,1A	3,1A	2,8A	2,8A
Cut in current	16,2A	16,2A	15,6A	15,6A

Model

Designation

SC10GH

220-240V/50Hz 1~ 208-230V/60Hz 1~

Sales code:

104G8041

Compressor dimensions

Housing	A Height	209mm / 8,23in
	B Height	203mm / 7,99in
	C Length shell	218mm / 8,58in
	D Length w. cover	255mm / 10,04in
	E Width	151mm / 5,94in

Connectors		Suction	Discharge	Process
		X	Y	Z
Diameter	[mm]	øi 10,11-10,29	øi 8,11-8,29	øi 6,11-6,29
(i:inside, o:outside)	[in]	øi 0,4-0,41	øi 0,32-0,33	øi 0,24-0,25
Material		copper	copper	copper
Horizontal angle	±2°	37°	37°	143°
Vertical angle	±2°	30°	0°	150°
Position l/h/w	[mm]	107/183/55	115/100/63	-107/183/55
	[in]	4,2/7,2/2,2	4,5/3,9/2,5	-4,2/7,2/2,2
Straight tube l.	[mm]	12	12	12
	[in]	0,5	0,5	0,5

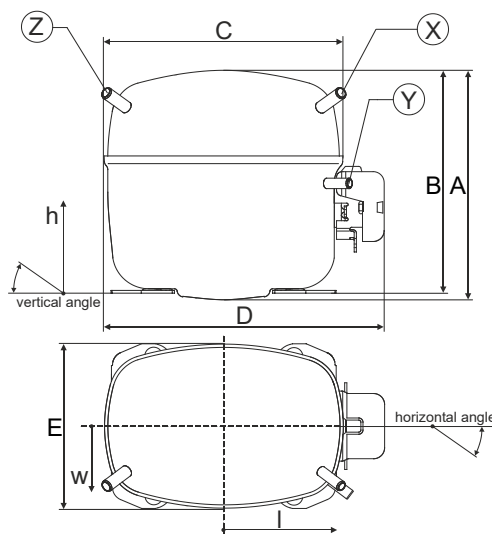

Compressor fixation



Bolt joint



Snap-on



Mounting accessories

	one comp.	multi pack
Bolt joint M6 ø16mm	118-1917	118-1918
Bolt joint ø1/4" ø16mm	118-1946	
Bolt joint ø1/4" ø19mm	118-1949	
Snap-on ø7,3 ø16mm	118-1947	118-1919

Application notes

Provision for PE Grounding is located at the PE Stamp on the compressor

Model

Designation	SC10GH	220-240V/50Hz	Conf. 1	Sales code:	104G8041
-------------	---------------	----------------------	----------------	-------------	-----------------

Configuration

Motorconfiguration	CSIR
Power supply (nominal)	220-240V/50Hz 1~
Refrigerant	R134a
Application	HBP
Voltage range	198-254V
Starting torque	HST
Approvals	VDE UL CCC KC

Electrical accessories / wiring diagram

CSIR

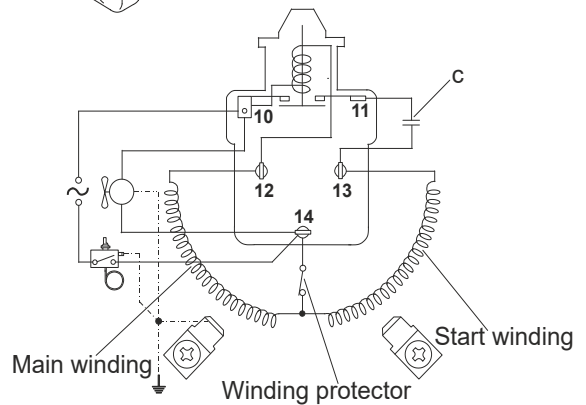
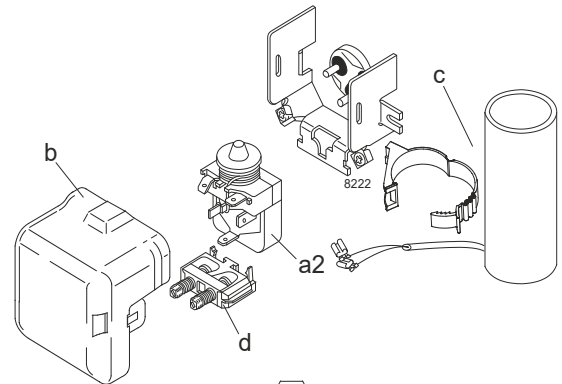

Ambient/ machine room temperatures minimum /maximum

Ambient temperature range:	10 - 43°C / 50 - 110°F
Machine room temperature range:	10 - 48°C / 50 - 119°F
Compressor cooling:	fan 3m/s

Operation Limits

Operation pressure range

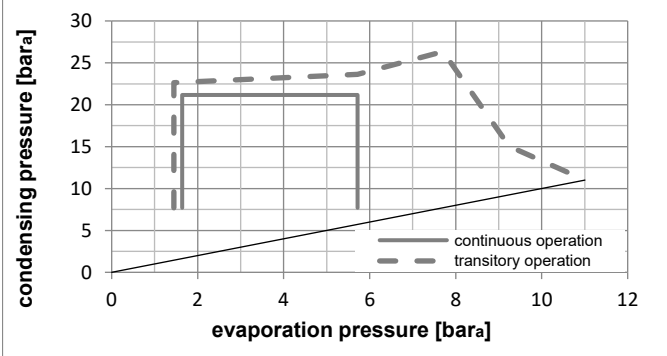
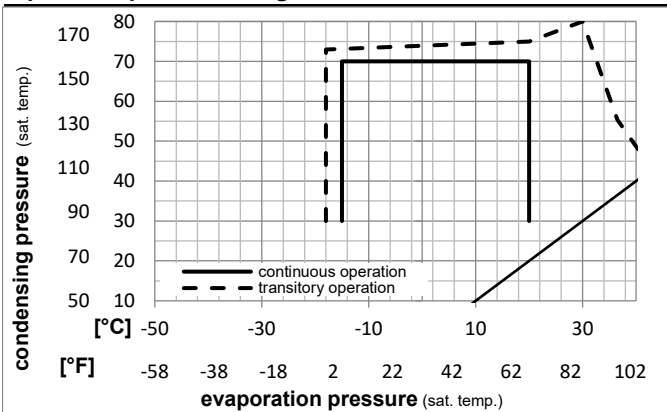

Components

a2	relay	117U6005
c	start capacitor (80μF)	117U5017
d	cord relief	103N1004
b	plastic cover	103N2008

Model

Designation **SC10GH** **220-240V/50Hz** Conf. 1 Sales code: **104G8041**

Optimization + standard conditions

R134a, 220V/50Hz, CSIR, fan 3m/s, VDE, UL, CCC, KC

		Evaporating pressure (saturation temperature)				Condensing pressure (saturation temperature)			Return gas temp.			Liquid temp.			Cooling capacity			COP	EER	Power consumption			
		pe	pc	RGT	Tliq	[W]	[Btu/h]	[kcal/h]	[W/W]	[Btu/Wh]	[kcal/Wh]	P1	I	Ref. mass flow									
[°C]	[°F]											[W]	[A]	[kg/h]									
7,2	45	54	35	46	925,4	3160	796,4	2,28	7,77	1,96	406,7	3,34	20,53	ASHRAE HBP									
5	41	55	32	55	761,6	2601	655,5	1,93	6,59	1,66	395,0	3,26	18,77	cecomaf HBP									
5	41	50	20	50	794,7	2714	683,9	2,11	7,21	1,82	376,2	3,13	20,02	EN12900 HBP									
-7	20	54	35	46	481,8	1646	414,7	1,56	5,34	1,35	308,0	2,72	10,51	ASHRAE MBP									
-10	14	55	32	55	352,2	1203	303,1	1,25	4,28	1,08	280,7	2,57	8,52	cecomaf MBP									
-10	14	45	20	45	407,4	1391	350,6	1,51	5,15	1,30	269,9	2,51	9,54	EN12900 MBP									

Performance tables

R134a, 220V/50Hz, CSIR, fan 3m/s, VDE, UL, CCC, KC

	pe		Cooling capacity			COP	EER	P1	I	m	
	[°C]	[°F]	[W]	[Btu/h]	[kcal/h]	[W/W]	[Btu/Wh]	[kcal/Wh]	[W]	[A]	[kg/h]
[°C / °F]	-15	5	294,5	1006	253,5	1,26	4,32	1,09	232,9	2,34	6,42
cond. pressure	-10	14	422,7	1444	363,8	1,57	5,35	1,35	269,9	2,51	9,25
pc= 45/113	-5	23	564,2	1927	485,6	1,86	6,36	1,60	303,2	2,68	12,41
return gas temp.	0	32	722,6	2468	621,9	2,17	7,42	1,87	332,7	2,85	15,98
RGT= 32/90	5	41	901,5	3079	775,8	2,51	8,59	2,16	358,6	3,01	20,07
liquid temp	15	59	1334,5	4558	1148,5	3,34	11,42	2,88	399,0	3,33	30,23
Tliq= 45/113	20	68	1595,8	5450	1373,4	3,86	13,18	3,32	413,7	3,48	36,55
[°C / °F]	-15	5	233,0	796	200,5	0,99	3,38	0,85	235,2	2,34	5,61
cond. pressure	-10	14	352,2	1203	303,1	1,25	4,28	1,08	280,7	2,57	8,52
pc= 55/131	-5	23	477,7	1631	411,1	1,48	5,06	1,27	322,6	2,80	11,61
return gas temp	0	32	613,0	2093	527,5	1,70	5,80	1,46	360,6	3,03	14,99
RGT= 32/90	5	41	761,6	2601	655,5	1,93	6,59	1,66	395,0	3,26	18,77
liquid temp	15	59	1113,1	3801	957,9	2,46	8,40	2,12	452,6	3,70	27,96
Tliq= 55/131	20	68	1323,0	4518	1138,6	2,78	9,50	2,39	475,7	3,92	33,64

Model

Designation	SC10GH	220-240V/50Hz	Conf. 2	Sales code:	104G8041
-------------	---------------	----------------------	----------------	-------------	-----------------

Configuration

Motorconfiguration	CSIR
Power supply (nominal)	220-240V/50Hz 1~
Refrigerant	R513A
Application	HBP
Voltage range	198-254V
Starting torque	HST
Approvals	VDE UL CCC

Electrical accessories / wiring diagram

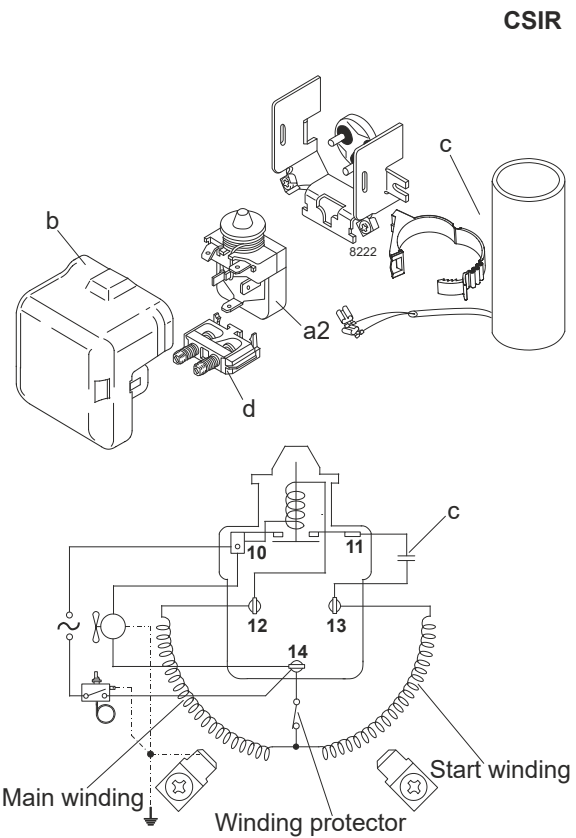

Ambient/ machine room temperatures minimum /maximum

Ambient temperature range:	10 - 43°C / 50 - 110°F
Machine room temperature range:	10 - 48°C / 50 - 119°F
Compressor cooling:	fan 3m/s

Operation Limits

Operation pressure range

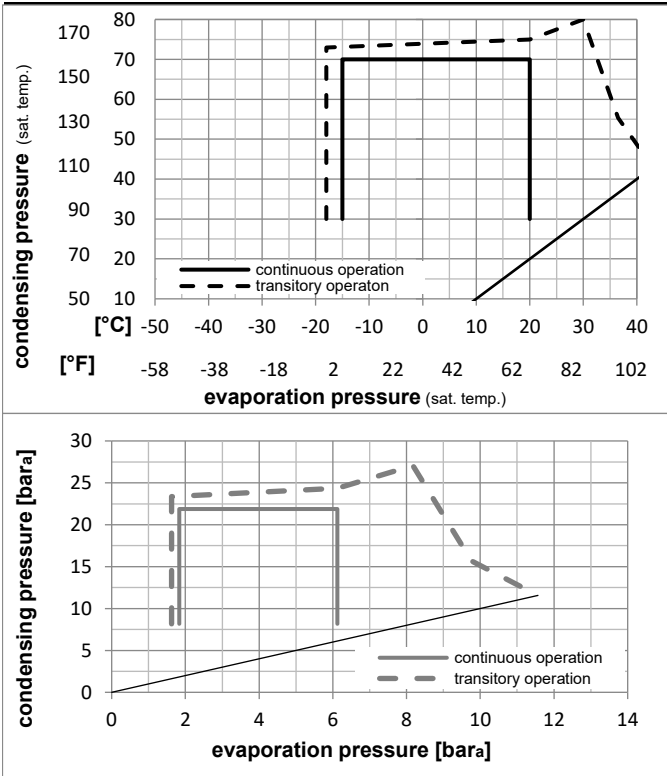

Components

a2	relay	117U6005
c	start capacitor (80μF)	117U5017
d	cord relief	103N1004
b	plastic cover	103N2008

Model

Designation **SC10GH** **220-240V/50Hz** Conf. 2 Sales code: **104G8041**

Optimization + standard conditions

R513A, 220V/50Hz, CSIR, fan 3m/s, VDE, UL, CCC

		Evaporating pressure (saturation temperature)				Condensing pressure (saturation temperature)						Power consumption			
		Return gas temp.		Liquid temp.		Cooling capacity		COP	EER		P1	I	Ref. mass flow		
		pe	pc	RGT	Tliq	[W]	[Btu/h]	[kcal/h]	[W/W]	[Btu/Wh]	[kcal/Wh]	[W]	[A]	[kg/h]	
[°C]	7,2	54	35	46	952,4	3252	819,6	2,24	7,66	1,93	424,4	3,49	23,66	ASHRAE HBP	
[°F]	45	130	95	115											
[°C]	5	55	32	55	772,4	2638	664,7	1,87	6,38	1,61	413,2	3,42	21,71	cecomaf HBP	
[°F]	41	131	90	131											
[°C]	5	50	20	50	807,0	2756	694,5	2,05	7,01	1,77	393,3	3,29	23,14	EN12900 HBP	
[°F]	41	122	68	122											
[°C]	-7	54	35	46	506,5	1730	435,9	1,55	5,30	1,34	326,4	2,87	12,41	ASHRAE MBP	
[°F]	20	130	95	115											
[°C]	-10	55	32	55	366,1	1250	315,1	1,23	4,18	1,05	298,8	2,70	10,12	cecomaf MBP	
[°F]	14	131	90	131											
[°C]	-10	45	20	45	426,4	1456	367,0	1,49	5,08	1,28	286,5	2,62	11,30	EN12900 MBP	
[°F]	14	113	68	113											

Performance tables

R513A, 220V/50Hz, CSIR, fan 3m/s, VDE, UL, CCC

	pe		Cooling capacity			COP	EER	P1			I	m
	[°C]	[°F]	[W]	[Btu/h]	[kcal/h]	[W/W]	[Btu/Wh]	[kcal/Wh]	[W]	[A]	[kg/h]	
[°C / °F]	-15	5	314,1	1073	270,3	1,26	4,32	1,09	248,4	2,38	7,70	
cond. pressure	-10	14	445,9	1523	383,7	1,56	5,31	1,34	286,5	2,62	10,96	
pc= 45/113	-5	23	590,0	2015	507,7	1,84	6,29	1,59	320,2	2,83	14,56	
return gas temp.	0	32	749,9	2561	645,4	2,15	7,33	1,85	349,6	3,02	18,60	
RGT= 32/90	5	41	929,2	3173	799,7	2,48	8,47	2,13	374,8	3,18	23,18	
liquid temp	15	59	1360,1	4645	1170,5	3,29	11,23	2,83	413,6	3,42	34,41	
Tliq= 45/113	20	68	1618,7	5528	1393,1	3,79	12,94	3,26	427,4	3,51	41,33	
[°C / °F]	-15	5	245,2	838	211,0	0,97	3,33	0,84	251,8	2,40	6,76	
cond. pressure	-10	14	366,1	1250	315,1	1,23	4,18	1,05	298,8	2,70	10,12	
pc= 55/131	-5	23	491,9	1680	423,3	1,44	4,92	1,24	341,2	2,96	13,66	
return gas temp	0	32	626,1	2138	538,8	1,65	5,64	1,42	379,3	3,20	17,49	
RGT= 32/90	5	41	772,4	2638	664,7	1,87	6,38	1,61	413,2	3,42	21,71	
liquid temp	15	59	1115,1	3808	959,7	2,38	8,12	2,05	469,0	3,77	31,85	
Tliq= 55/131	20	68	1318,6	4503	1134,8	2,68	9,17	2,31	491,2	3,91	38,05	

Model

Designation	SC10GH	208-230V/60Hz	Conf. 3	Sales code:	104G8041
-------------	---------------	----------------------	----------------	-------------	-----------------

Configuration

Motorconfiguration	CSIR
Power supply (nominal)	208-230V/60Hz 1~
Refrigerant	R134a
Application	HBP
Voltage range	198-254V
Starting torque	HST
Approvals	VDE UL CCC KC

Electrical accessories / wiring diagram

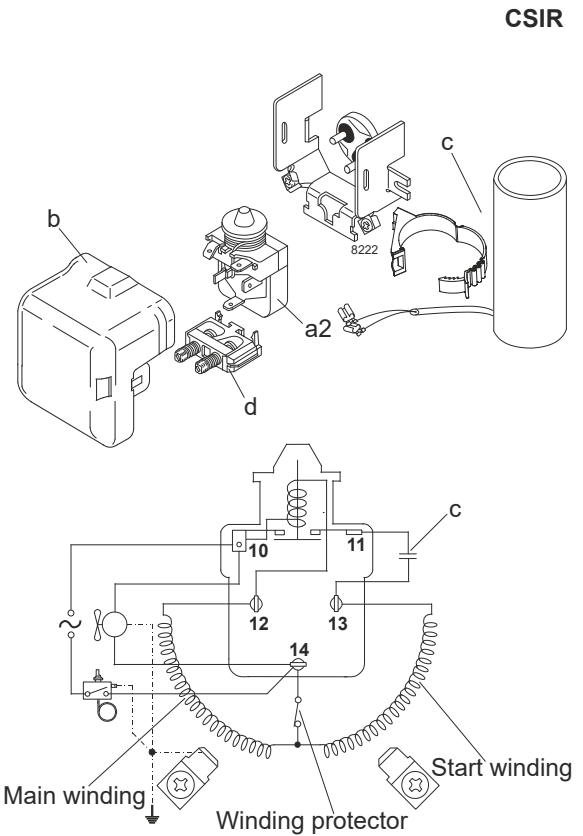

Ambient/ machine room temperatures minimum /maximum

Ambient temperature range:	10 - 43°C / 50 - 110°F
Machine room temperature range:	10 - 48°C / 50 - 119°F
Compressor cooling:	fan 3m/s

Operation Limits

Operation pressure range

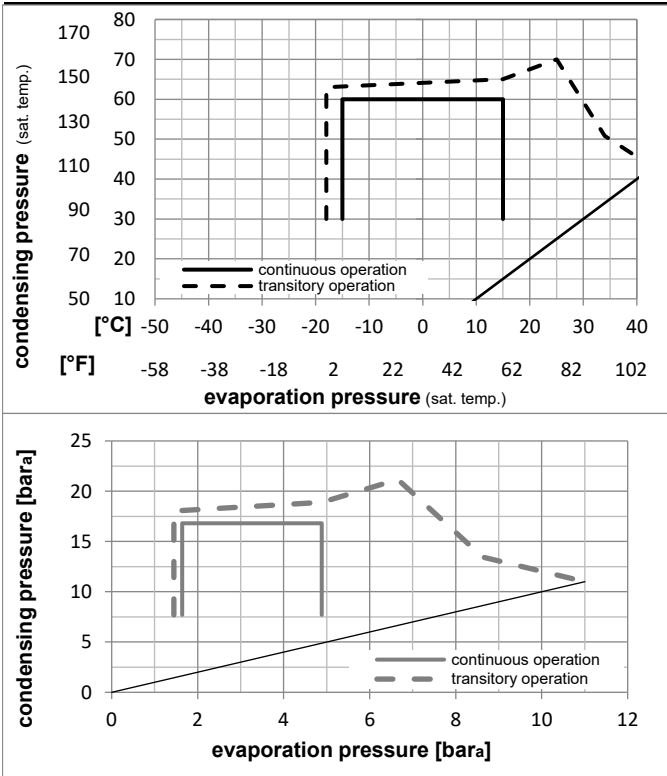

Components

a2	relay	117U6005
c	start capacitor (80μF)	117U5017
d	cord relief	103N1004
b	plastic cover	103N2008

Model

Designation **SC10GH** **208-230V/60Hz** Conf. 3 Sales code: **104G8041**

Optimization + standard conditions

R134a, 230V/60Hz, CSIR, fan 3m/s, VDE, UL, CCC, KC

		Evaporating pressure (saturation temperature)				Condensing pressure (saturation temperature)						Power consumption			
		Return gas temp.		Liquid temp.		Cooling capacity		COP	EER		P1	I	Ref. mass flow		
		pe	pc	RGT	Tliq	[W]	[Btu/h]	[kcal/h]	[W/W]	[Btu/Wh]	[kcal/Wh]	[W]	[A]	[kg/h]	
[°C]	7,2	54	35	46	1037,8	3544	893,1	2,02	6,89	1,74	514,2	3,27	23,02	ASHRAE HBP	
[°F]	45	130	95	115											
[°C]	5	55	32	55	848,9	2899	730,6	1,71	5,85	1,47	495,5	3,18	20,92	cecomaf HBP	
[°F]	41	131	90	131											
[°C]	5	50	20	50	907,1	3098	780,6	1,94	6,62	1,67	468,2	2,91	22,86	EN12900 HBP	
[°F]	41	122	68	122											
[°C]	-7	54	35	46	556,2	1899	478,6	1,49	5,08	1,28	374,2	2,52	12,13	ASHRAE MBP	
[°F]	20	130	95	115											
[°C]	-10	55	32	55	420,5	1436	361,9	1,24	4,23	1,07	339,6	2,37	10,17	cecomaf MBP	
[°F]	14	131	90	131											
[°C]	-10	45	20	45	515,6	1761	443,7	1,53	5,23	1,32	336,8	2,19	12,07	EN12900 MBP	
[°F]	14	113	68	113											

Performance tables

R134a, 230V/60Hz, CSIR, fan 3m/s, VDE, UL, CCC, KC

	pe		Cooling capacity			COP	EER	P1			I	m
	[°C]	[°F]	[W]	[Btu/h]	[kcal/h]	[W/W]	[Btu/Wh]	[kcal/Wh]	[W]	[A]	[kg/h]	
[°C / °F]	-15	5	420,8	1437	362,2	1,40	4,78	1,20	300,8	2,05	9,17	
cond. pressure	-10	14	534,9	1827	460,3	1,59	5,42	1,37	336,8	2,19	11,71	
pc= 45/113	-5	23	673,9	2302	580,0	1,81	6,18	1,56	372,7	2,35	14,82	
return gas temp.	0	32	840,8	2871	723,6	2,06	7,04	1,77	408,0	2,52	18,59	
RGT= 32/90	5	41	1038,3	3546	893,6	2,35	8,02	2,02	442,2	2,69	23,12	
liquid temp	10	50	1269,4	4335	1092,4	2,67	9,13	2,30	474,7	2,88	28,48	
Tliq= 45/113	15	59	1536,8	5249	1322,6	3,04	10,39	2,62	505,0	3,07	34,81	
[°C / °F]	-15	5	318,4	1087	274,0	1,11	3,79	0,95	287,2	2,13	7,66	
cond. pressure	-10	14	420,5	1436	361,9	1,24	4,23	1,07	339,6	2,37	10,17	
pc= 55/131	-5	23	541,1	1848	465,7	1,38	4,71	1,19	392,1	2,63	13,15	
return gas temp	0	32	682,9	2332	587,7	1,54	5,25	1,32	444,3	2,90	16,70	
RGT= 32/90	5	41	848,9	2899	730,6	1,71	5,85	1,47	495,5	3,18	20,92	
liquid temp	10	50	1041,9	3558	896,6	1,91	6,53	1,64	545,3	3,46	25,90	
Tliq= 55/131	15	59	1264,7	4319	1088,4	2,13	7,28	1,84	593,1	3,76	31,77	

Model

Designation	SC10GH	208-230V/60Hz	Conf. 4	Sales code:	104G8041
-------------	---------------	----------------------	----------------	-------------	-----------------

Configuration

Motorconfiguration	CSIR
Power supply (nominal)	208-230V/60Hz 1~
Refrigerant	R513A
Application	HBP
Voltage range	198-254V
Starting torque	HST
Approvals	VDE UL CCC

Electrical accessories / wiring diagram

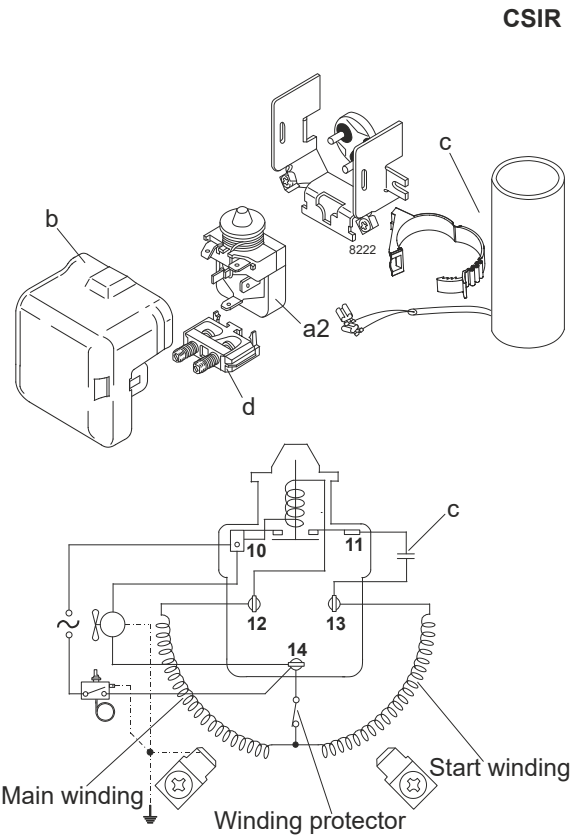

Ambient/ machine room temperatures minimum /maximum

Ambient temperature range:	10 - 43°C / 50 - 110°F
Machine room temperature range:	10 - 48°C / 50 - 119°F
Compressor cooling:	fan 3m/s

Operation Limits

Operation pressure range

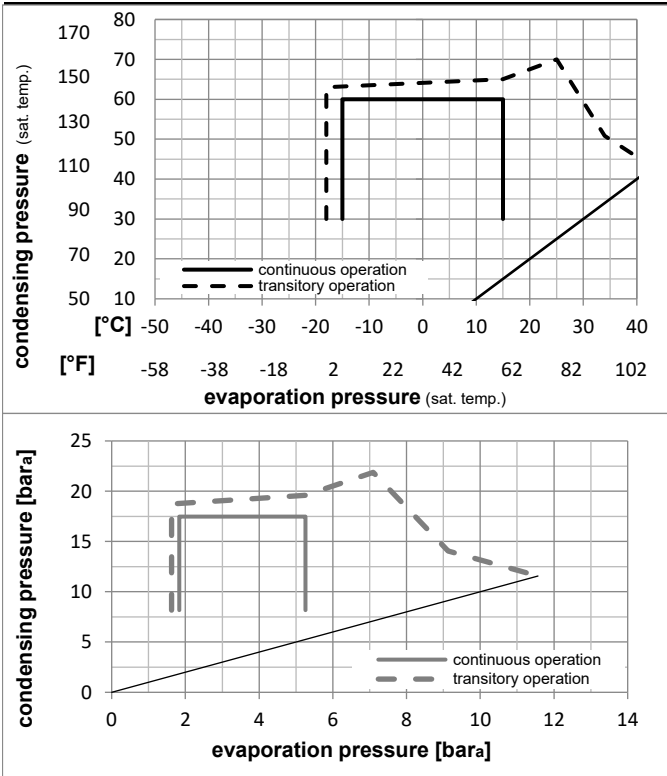

Components

a2	relay	117U6005
c	start capacitor (80μF)	117U5017
d	cord relief	103N1004
b	plastic cover	103N2008

Model

Designation **SC10GH** **208-230V/60Hz** Conf. 4 Sales code: **104G8041**

Optimization + standard conditions

R513A, 230V/60Hz, CSIR, fan 3m/s, VDE, UL, CCC

		Evaporating pressure (saturation temperature)				Cooling capacity			COP			EER			Power consumption			
		Condensing pressure (saturation temperature)		Return gas temp.		Liquid temp.					Current consumption			Ref. mass flow				
		pe	pc	RGT	Tliq	[W]	[Btu/h]	[kcal/h]	[W/W]	[Btu/Wh]	[kcal/Wh]	P1	I	m	[W]	[A]	[kg/h]	
[°C]	[°F]																	
[°C]	[°F]	7,2	54	35	46	1068,1	3648	919,2	1,99	6,79	1,71	537,1	3,39	26,53				ASHRAE HBP
[°C]	[°F]	45	130	95	115													
[°C]	[°F]	5	55	32	55	860,9	2940	740,9	1,66	5,67	1,43	518,7	3,29	24,19				cecomaf HBP
[°C]	[°F]	41	131	90	131													
[°C]	[°F]	5	50	20	50	921,4	3147	793,0	1,88	6,42	1,62	490,1	3,13	26,42				EN12900 HBP
[°C]	[°F]	41	122	68	122													
[°C]	[°F]	-7	54	35	46	584,9	1997	503,3	1,47	5,03	1,27	396,7	2,62	14,33				ASHRAE MBP
[°C]	[°F]	20	130	95	115													
[°C]	[°F]	-10	55	32	55	437,3	1494	376,4	1,21	4,13	1,04	361,5	2,42	12,09				cecomaf MBP
[°C]	[°F]	14	131	90	131													
[°C]	[°F]	-10	45	20	45	539,8	1843	464,5	1,51	5,15	1,30	357,8	2,40	14,31				EN12900 MBP
[°C]	[°F]	14	113	68	113													

Performance tables

R513A, 230V/60Hz, CSIR, fan 3m/s, VDE, UL, CCC

	pe		Cooling capacity			COP			EER			P1	I	m
	[°C]	[°F]	[W]	[Btu/h]	[kcal/h]	[W/W]	[Btu/Wh]	[kcal/Wh]	[W]	[A]	[kg/h]			
[°C / °F]	-15	5	448,6	1532	386,0	1,40	4,77	1,20	321,0	2,20	10,99			
cond. pressure	-10	14	564,5	1928	485,8	1,58	5,39	1,36	357,8	2,40	13,88			
pc= 45/113	-5	23	705,0	2408	606,7	1,79	6,11	1,54	394,0	2,60	17,40			
return gas temp.	0	32	872,9	2981	751,2	2,03	6,95	1,75	429,1	2,79	21,65			
RGT= 32/90	5	41	1070,6	3656	921,4	2,31	7,90	1,99	462,8	2,98	26,70			
liquid temp	10	50	1301,0	4443	1119,7	2,63	8,99	2,26	494,5	3,15	32,66			
Tliq= 45/113	15	59	1566,6	5350	1348,2	2,99	10,21	2,57	523,8	3,31	39,64			
[°C / °F]	-15	5	335,2	1145	288,4	1,09	3,72	0,94	307,5	2,13	9,23			
cond. pressure	-10	14	437,3	1494	376,4	1,21	4,13	1,04	361,5	2,42	12,09			
pc= 55/131	-5	23	557,3	1903	479,6	1,34	4,59	1,16	415,0	2,72	15,48			
return gas temp	0	32	697,6	2382	600,3	1,49	5,10	1,28	467,5	3,01	19,48			
RGT= 32/90	5	41	860,9	2940	740,9	1,66	5,67	1,43	518,7	3,29	24,19			
liquid temp	10	50	1049,9	3586	903,6	1,85	6,31	1,59	568,1	3,56	29,73			
Tliq= 55/131	15	59	1267,3	4328	1090,6	2,06	7,03	1,77	615,2	3,82	36,19			