

Model

Designation	SC10MLX	220-240V/50Hz 1~ 208-230V/60Hz 1~	Sales code:	104L2506
-------------	----------------	-----------------------------------	-------------	-----------------

Compressor design

Oil type	Polyolester	Refrigerant(s)	R404A, R452A, R507
Oil viscosity	32cST	Displacement	10,29cm ³ / 0,63cu.in
Oil quantity	550cm ³ / 18,6fl.oz	Compressors on pallet	80
Refr. charge - tech. limit	1300g / 45,9oz		
Free gas volume comp.	1410cm ³ / 47,7fl.oz		
Weight	13kg / 28,7lbs		
Motor protection	1# internal		
Winding resistance main	4,4Ω (at 25°C)		
Winding resistance aux	14Ω (at 25°C)		
Max. winding temp.	125°C / 257°F		
Max. discharge temp.	130°C / 266°F		



General - Configurations with SC10MLX

	Conf. 1	Conf. 2	Conf. 3	Conf. 4	Conf. 5
Motorconfiguration	CSIR	CSIR	CSIR	CSIR	CSIR
Power supply (nominal)	220-240V/50Hz	208-230V/60Hz	220-240V/50Hz	220-240V/50Hz	220-240V/50Hz
Number of phases	1	1	1	1	1
Voltage range	187-254V	187-254V	187-254V	187-254V	187-254V
Approvals	VDE, UL, CCC, KC, EAC	VDE, UL, CCC, KC, EAC	VDE, UL, CCC, KC, EAC	VDE, UL, CCC, KC, EAC	VDE, UL, CCC, KC, EAC
Starting torque	HST	HST	HST	HST	HST
Note	- / -	- / -	- / -	- / -	- / -

Applications with SC10MLX

	Conf. 1	Conf. 2	Conf. 3	Conf. 4	Conf. 5
Refrigerant	R404A	R404A	R452A	R448A	R449A
Application	MBP	MBP	MBP	MBP	MBP
System cooling	fan 3m/s	fan 3m/s	fan 3m/s	fan 3m/s	fan 3m/s
Hot gas defrost	OK	OK	OK	OK	OK
Long interval pull down	OK	OK	OK	OK	OK

Electrical data - Configurations with SC10MLX

	Conf. 1	Conf. 2	Conf. 3	Conf. 4	Conf. 5
Starting device type	relay	relay	relay	relay	relay
Run capacitor	- / -	- / -	- / -	- / -	- / -
Start capacitor	80μF	80μF	80μF	80μF	80μF
LRA (locked rotor amps / 4s)	19A	18,3A	19A	19A	19A
RLA (rated load amps / 1s)	3,9A	3,52A	3,9A	3,9A	3,9A
Cut in current	19A	18,3A	19A	19A	19A

Model

Designation

SC10MLX

220-240V/50Hz 1~ 208-230V/60Hz 1~

Sales code:

104L2506

Compressor dimensions

Housing	A Height	209mm / 8,23in
	B Height	203mm / 7,99in
	C Length shell	218mm / 8,58in
	D Length w. cover	255mm / 10,04in
	E Width	151mm / 5,94in

Connectors	Suction X	Discharge Y	Process Z
Diameter [mm]	øi 8,11-8,29	øi 6,41-6,59	øi 6,41-6,59
(i:inside, o:outside) [in]	øi 0,32-0,33	øi 0,25-0,26	øi 0,25-0,26
Material	copper	copper	copper
Horizontal angle ±2°	37°	37°	143°
Vertical angle ±2°	30°	0°	150°
Position l/h/w [mm]	107/183/55	115/100/63	-107/183/55
[in]	4,2/7,2/2,2	4,5/3,9/2,5	-4,2/7,2/2,2
Straight tube l. [mm]	12	12	12
[in]	0,5	0,5	0,5

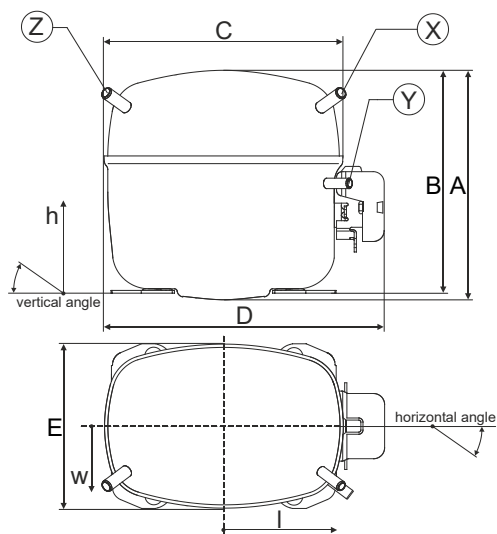

Compressor fixation

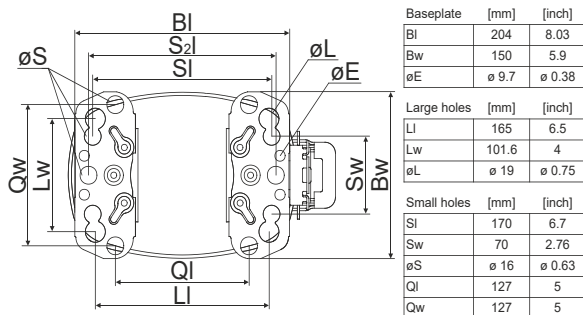

Bolt joint

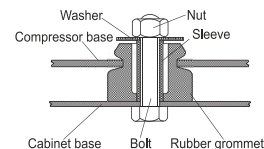

Snap-on

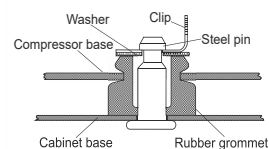

Mounting accessories

	one comp.	multi pack
Bolt joint M6 ø16mm	118-1917	118-1918
Bolt joint ø1/4" ø16mm	118-1946	
Bolt joint ø1/4" ø19mm	118-1949	
Snap-on ø7,3 ø16mm	118-1947	118-1919

Application notes

LRA value on compressor label and datasheet may differ due to different test conditions for UL approval.

Provision for PE Grounding is located at the PE Stamp on the compressor

Model

Designation	SC10MLX	220-240V/50Hz	Conf. 1	Sales code:	104L2506
-------------	----------------	----------------------	----------------	-------------	-----------------

Configuration

Motorconfiguration	CSIR
Power supply (nominal)	220-240V/50Hz 1~
Refrigerant	R404A
Application	MBP
Voltage range	187-254V
Starting torque	HST
Approvals	VDE UL CCC KC EAC

Electrical accessories / wiring diagram

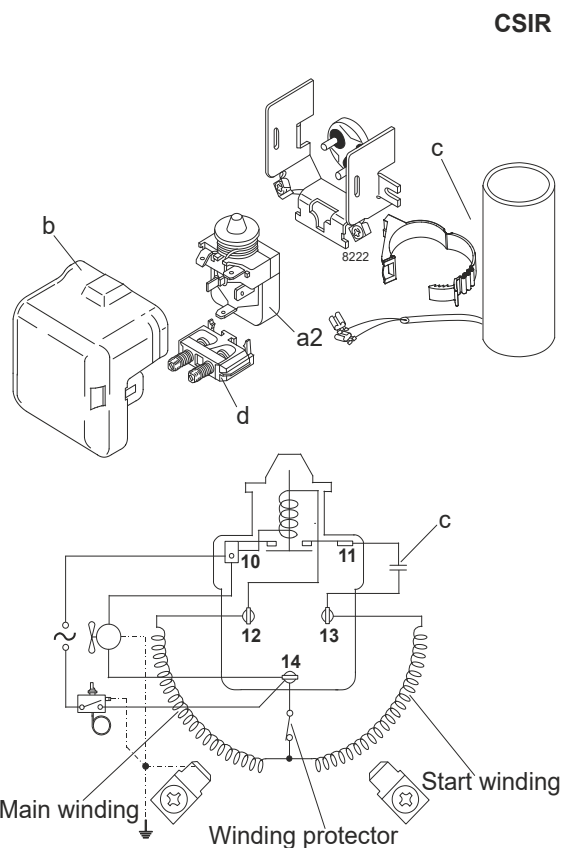

Ambient/ machine room temperatures minimum /maximum

Ambient temperature range:	10 - 43°C / 50 - 110°F
Machine room temperature range:	10 - 48°C / 50 - 119°F
Compressor cooling:	fan 3m/s

Operation Limits

Operation pressure range

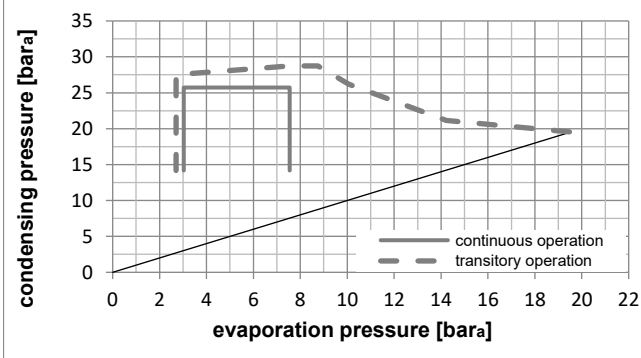
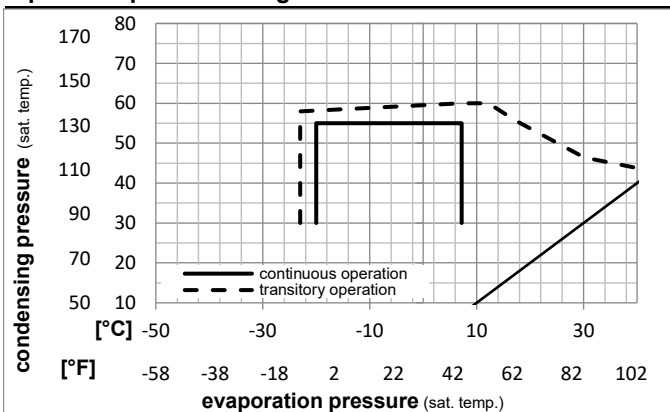

Components

a2	relay	117U6011
c	start capacitor (80μF)	117U5017
d	cord relief	103N1004
b	plastic cover	103N2008

Model

Designation **SC10MLX** **220-240V/50Hz** Conf. 1 Sales code: **104L2506**

Optimization + standard conditions

R404A, 220V/50Hz, CSIR, fan 3m/s, VDE, UL, CCC, KC, EAC

	Evaporating pressure (saturation temperature)				Condensing pressure (saturation temperature)			Return gas temp.	Liquid temp.	Cooling capacity	COP	EER	Power consumption			ASHRAE MBP
	pe	pc	RGT	Tliq	[W]	[Btu/h]	[kcal/h]						P1	I	Ref. mass flow	
[°C]	-7	54	35	46	902,9	3084	777,0	1,54	5,25	1,32	587,7	3,91	24,84			
[°F]	20	130	95	115												
	-10	55	32	55	668,3	2282	575,1	1,20	4,08	1,03	559,1	3,79	21,39	cecomaf MBP		
	-10	45	20	45	805,8	2752	693,4	1,55	5,31	1,34	518,5	3,65	24,27	EN12900 MBP		
	-7	49	18	49	835,8	2854	719,3	1,49	5,08	1,28	561,7	3,81	27,31	ARI540 MBP		
	-10	45	32	45	855,1	2920	735,9	1,65	5,63	1,42	518,5	3,65	23,55	opt		
	-25	45	32	45	426,9	1458	367,4	1,06	3,62	0,91	402,9	3,28	11,51	opt		

Performance tables

R404A, 220V/50Hz, CSIR, fan 3m/s, VDE, UL, CCC, KC, EAC

	pe		Cooling capacity			COP	EER	P1	I	m	
	[°C]	[°F]	[W]	[Btu/h]	[kcal/h]	[W/W]	[Btu/Wh]	[kcal/Wh]	[W]	[A]	[kg/h]
[°C / °F]	-20	-4	545,5	1863	469,5	1,23	4,21	1,06	442,1	3,39	14,80
cond. pressure	-15	5	687,4	2348	591,6	1,43	4,89	1,23	480,5	3,51	18,78
pc= 45/113	-10	14	855,1	2920	735,9	1,65	5,63	1,42	518,5	3,65	23,55
return gas temp.	-7	20	981,1	3351	844,4	1,81	6,17	1,55	543,4	3,75	27,18
RGT= 32/90	-5	23	1051,1	3590	904,5	1,89	6,45	1,63	556,3	3,80	29,22
liquid temp	0	32	1277,6	4363	1099,6	2,15	7,34	1,85	594,3	3,96	35,92
Tliq= 45/113	7,2	45	1662,8	5679	1431,0	2,56	8,73	2,20	650,2	4,23	47,68
[°C / °F]	-20	-4	413,8	1413	356,1	0,90	3,06	0,77	462,0	3,45	13,02
cond. pressure	-15	5	531,5	1815	457,4	1,04	3,55	0,89	511,3	3,61	16,86
pc= 55/131	-10	14	668,3	2282	575,1	1,20	4,08	1,03	559,1	3,79	21,39
return gas temp	-7	20	770,2	2630	662,8	1,31	4,46	1,12	589,9	3,91	24,83
RGT= 32/90	-5	23	826,6	2823	711,3	1,36	4,66	1,17	605,6	3,98	26,75
liquid temp	0	32	1008,8	3445	868,2	1,55	5,29	1,33	651,2	4,18	33,08
Tliq= 55/131	7,2	45	1318,2	4502	1134,4	1,84	6,29	1,58	715,9	4,50	44,24

Model

Designation	SC10MLX	208-230V/60Hz	Conf. 2	Sales code:	104L2506
-------------	----------------	----------------------	----------------	-------------	-----------------

Configuration

Motorconfiguration	CSIR
Power supply (nominal)	208-230V/60Hz 1~
Refrigerant	R404A
Application	MBP
Voltage range	187-254V
Starting torque	HST
Approvals	VDE UL CCC KC EAC

Electrical accessories / wiring diagram

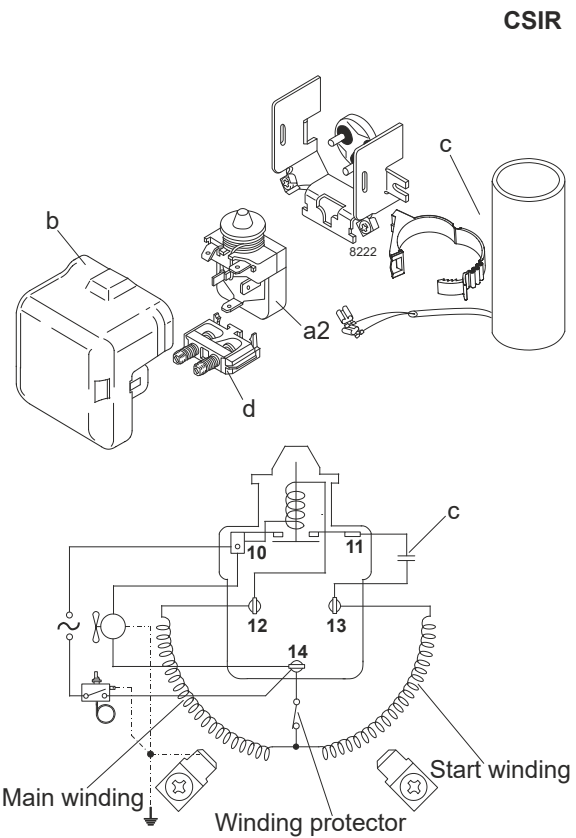

Ambient/ machine room temperatures minimum /maximum

Ambient temperature range:	10 - 43°C / 50 - 110°F
Machine room temperature range:	10 - 48°C / 50 - 119°F
Compressor cooling:	fan 3m/s

Operation Limits

Operation pressure range

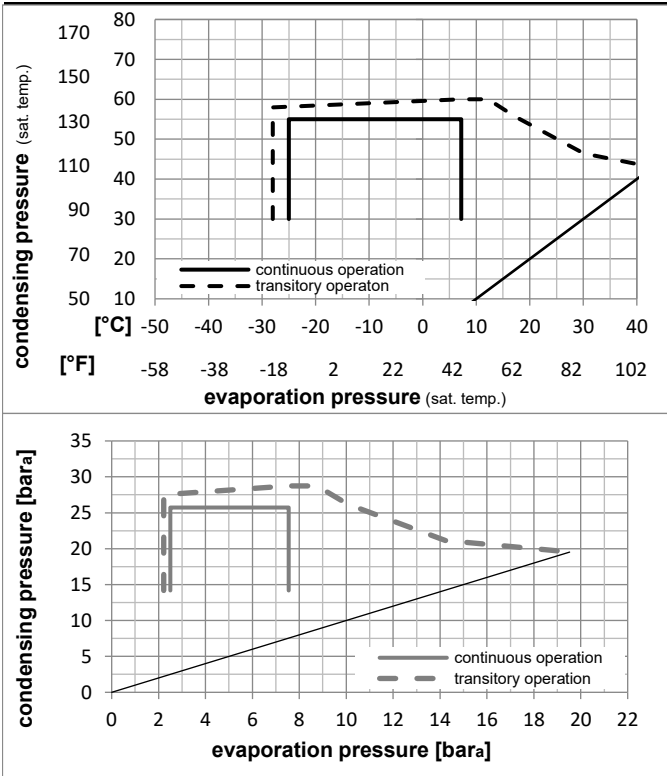

Components

a2	relay	117U6011
c	start capacitor (80μF)	117U5017
d	cord relief	103N1004
b	plastic cover	103N2008

Model

Designation **SC10MLX** **208-230V/60Hz** Conf. 2 Sales code: **104L2506**

Optimization + standard conditions

R404A, 220V/60Hz, CSIR, fan 3m/s, VDE, UL, CCC, KC, EAC

		Evaporating pressure (saturation temperature)				Condensing pressure (saturation temperature)						Power consumption			
		Return gas temp.		Liquid temp.		Cooling capacity		COP	EER		P1	I	Ref. mass flow		
		pe	pc	RGT	Tliq	[W]	[Btu/h]	[kcal/h]	[W/W]	[Btu/Wh]	[kcal/Wh]	[W]	[A]	[kg/h]	
[°C]	-7	54	35	46	1065,1	3638	916,6	1,53	5,22	1,32	697,0	3,80	29,31	ASHRAE MBP	
[°F]	20	130	95	115											
[°C]	-10	55	32	55	785,5	2683	676,0	1,20	4,11	1,04	652,1	3,59	25,15	cecomaf MBP	
[°F]	14	131	90	131											
[°C]	-10	45	20	45	956,7	3267	823,4	1,56	5,34	1,35	611,6	3,44	28,82	EN12900 MBP	
[°F]	14	113	68	113											
[°C]	-7	49	18	49	987,7	3373	850,0	1,47	5,04	1,27	669,7	3,69	32,27	ARI540 MBP	
[°F]	20	120	65	120											
[°C]	-10	45	32	45	1015,4	3468	873,8	1,66	5,67	1,43	611,6	3,44	27,96	opt	
[°F]	14	113	90	113											
[°C]	-25	45	32	45	499,7	1707	430,1	1,11	3,77	0,95	452,1	2,81	13,48	opt	
[°F]	-13	113	90	113											

Performance tables

R404A, 220V/60Hz, CSIR, fan 3m/s, VDE, UL, CCC, KC, EAC

	pe		Cooling capacity			COP	EER	P1	I	m	
	[°C]	[°F]	[W]	[Btu/h]	[kcal/h]	[W/W]	[Btu/Wh]	[kcal/Wh]	[W]	[A]	[kg/h]
[°C / °F]	-25	-13	499,7	1707	430,1	1,11	3,77	0,95	452,1	2,81	13,48
cond. pressure	-20	-4	645,6	2205	555,6	1,28	4,37	1,10	504,3	2,99	17,52
pc= 45/113	-15	5	816,4	2788	702,6	1,47	5,01	1,26	556,6	3,20	22,30
return gas temp.	-10	14	1015,4	3468	873,8	1,66	5,67	1,43	611,6	3,44	27,96
RGT= 32/90	-5	23	1245,6	4254	1072,0	1,85	6,33	1,60	671,7	3,72	34,63
liquid temp	0	32	1510,2	5158	1299,7	2,04	6,97	1,76	739,5	4,02	42,46
Tliq= 45/113	7,2	45	1957,9	6687	1685,0	2,29	7,81	1,97	855,6	4,53	56,14
[°C / °F]	-25	-13	347,8	1188	299,4	0,80	2,73	0,69	435,0	2,81	10,87
cond. pressure	-20	-4	474,3	1620	408,2	0,93	3,18	0,80	510,2	3,04	14,92
pc= 55/131	-15	5	619,2	2115	532,9	1,06	3,64	0,92	581,7	3,30	19,64
return gas temp	-10	14	785,5	2683	676,0	1,20	4,11	1,04	652,1	3,59	25,15
RGT= 32/90	-5	23	976,5	3335	840,4	1,35	4,61	1,16	723,8	3,92	31,61
liquid temp	0	32	1195,2	4082	1028,6	1,50	5,11	1,29	799,4	4,28	39,19
Tliq= 55/131	7,2	45	1565,2	5345	1347,0	1,70	5,81	1,46	920,0	4,85	52,53

Model

Designation	SC10MLX	220-240V/50Hz	Conf. 3	Sales code:	104L2506
-------------	----------------	----------------------	----------------	-------------	-----------------

Configuration

Motorconfiguration	CSIR
Power supply (nominal)	220-240V/50Hz 1~
Refrigerant	R452A
Application	MBP
Voltage range	187-254V
Starting torque	HST
Approvals	VDE UL CCC KC EAC

Electrical accessories / wiring diagram

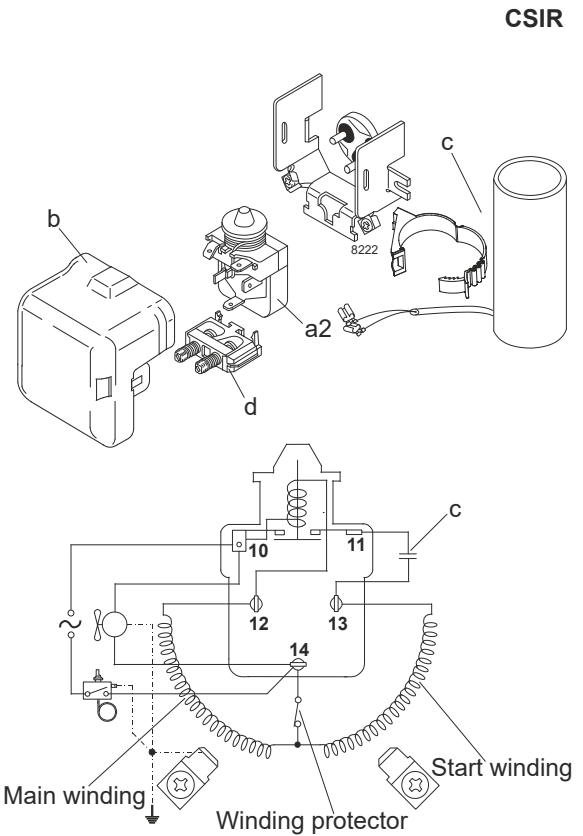

Ambient/ machine room temperatures minimum /maximum

Ambient temperature range:	10 - 43°C / 50 - 110°F
Machine room temperature range:	10 - 48°C / 50 - 119°F
Compressor cooling:	fan 3m/s

Operation Limits

Operation pressure range

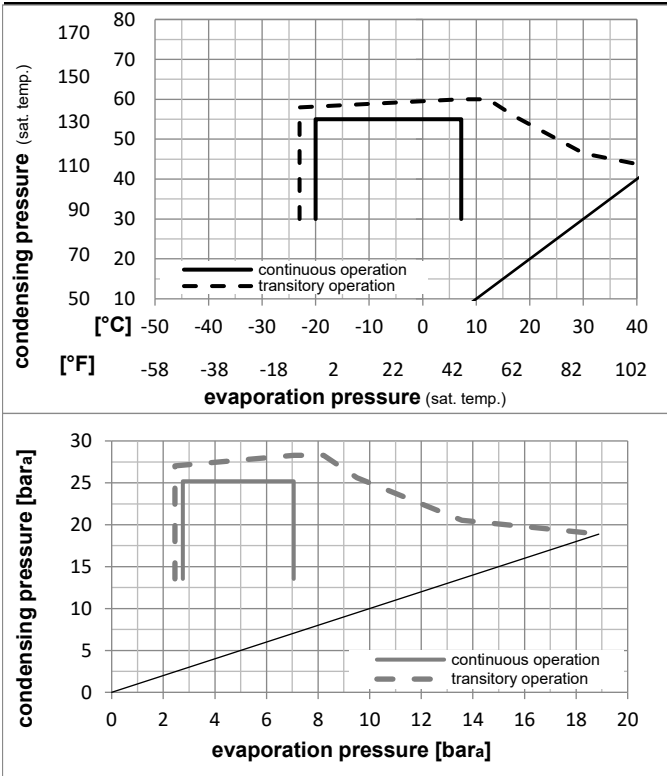

Components

a2	relay	117U6011
c	start capacitor (80μF)	117U5017
d	cord relief	103N1004
b	plastic cover	103N2008

Model

Designation **SC10MLX** **220-240V/50Hz** Conf. 3 Sales code: **104L2506**

Optimization + standard conditions

R452A, 220V/50Hz, CSIR, fan 3m/s, VDE, UL, CCC, KC, EAC

		Evaporating pressure (saturation temperature)				Condensing pressure (saturation temperature)						Power consumption			
		Return gas temp.		Liquid temp.		Cooling capacity		COP	EER		P1	I	Ref. mass flow		
		pe	pc	RGT	Tliq	[W]	[Btu/h]	[kcal/h]	[W/W]	[Btu/Wh]	[kcal/Wh]	[W]	[A]	[kg/h]	
[°C]	-7	54	35	46	848,8	2899	730,5	1,51	5,17	1,30	560,4	3,87	23,88	ASHRAE MBP	
[°F]	20	130	95	115											
[°C]	-10	55	32	55	628,8	2147	541,1	1,19	4,05	1,02	530,4	3,76	20,44	cecomaf MBP	
[°F]	14	131	90	131											
[°C]	-10	45	20	45	757,1	2585	651,5	1,53	5,24	1,32	493,3	3,63	23,26	EN12900 MBP	
[°F]	14	113	68	113											
[°C]	-7	49	18	49	790,5	2700	680,3	1,47	5,03	1,27	536,4	3,78	26,23	ARI540 MBP	
[°F]	20	120	65	120											
[°C]	-10	45	32	45	802,2	2740	690,4	1,63	5,55	1,40	493,3	3,63	22,60	opt	
[°F]	14	113	90	113											
[°C]	-25	45	32	45	389,1	1329	334,8	1,04	3,55	0,89	374,8	3,19	10,76	opt	
[°F]	-13	113	90	113											

Performance tables

R452A, 220V/50Hz, CSIR, fan 3m/s, VDE, UL, CCC, KC, EAC

	pe		Cooling capacity			COP	EER	P1	I	m	
	[°C]	[°F]	[W]	[Btu/h]	[kcal/h]	[W/W]	[Btu/Wh]	[kcal/Wh]	[W]	[A]	[kg/h]
[°C / °F]	-20	-4	503,0	1718	432,9	1,21	4,14	1,04	414,8	3,33	13,99
cond. pressure	-15	5	639,9	2185	550,7	1,41	4,81	1,21	454,2	3,48	17,90
pc= 45/113	-10	14	802,2	2740	690,4	1,63	5,55	1,40	493,3	3,63	22,60
return gas temp.	-7	20	924,6	3158	795,7	1,78	6,08	1,53	519,2	3,72	26,19
RGT= 32/90	-5	23	992,7	3390	854,3	1,86	6,36	1,60	532,6	3,77	28,21
liquid temp	0	32	1213,8	4145	1044,6	2,12	7,24	1,82	572,4	3,92	34,84
Tliq= 45/113	7,2	45	1591,5	5435	1369,7	2,52	8,61	2,17	631,3	4,14	46,49
[°C / °F]	-20	-4	381,1	1302	328,0	0,89	3,02	0,76	430,5	3,39	12,20
cond. pressure	-15	5	495,4	1692	426,3	1,03	3,52	0,89	481,1	3,58	15,97
pc= 55/131	-10	14	628,8	2147	541,1	1,19	4,05	1,02	530,4	3,76	20,44
return gas temp	-7	20	728,6	2488	627,0	1,30	4,42	1,11	562,4	3,88	23,83
RGT= 32/90	-5	23	784,0	2677	674,7	1,35	4,63	1,17	578,8	3,94	25,73
liquid temp	0	32	963,5	3291	829,2	1,54	5,25	1,32	626,7	4,12	31,99
Tliq= 55/131	7,2	45	1270,2	4338	1093,1	1,83	6,24	1,57	695,4	4,37	43,05

Model

Designation	SC10MLX	220-240V/50Hz	Conf. 4	Sales code:	104L2506
-------------	----------------	----------------------	----------------	-------------	-----------------

Configuration

Motorconfiguration	CSIR
Power supply (nominal)	220-240V/50Hz 1~
Refrigerant	R448A
Application	MBP
Voltage range	187-254V
Starting torque	HST
Approvals	

Electrical accessories / wiring diagram

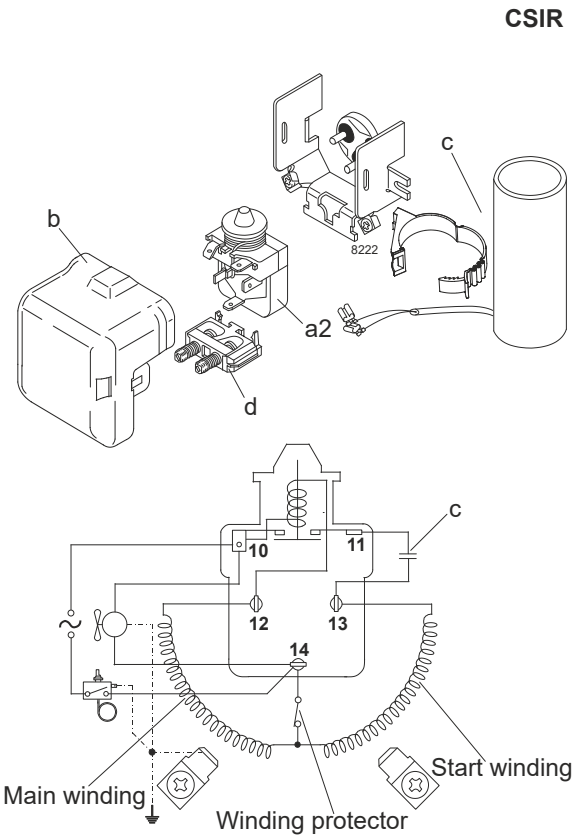

Ambient/ machine room temperatures minimum /maximum

Ambient temperature range:	10 - 38°C / 50 - 101°F
Machine room temperature range:	10 - 43°C / 50 - 110°F
Compressor cooling:	fan 3m/s

Operation Limits

Operation pressure range

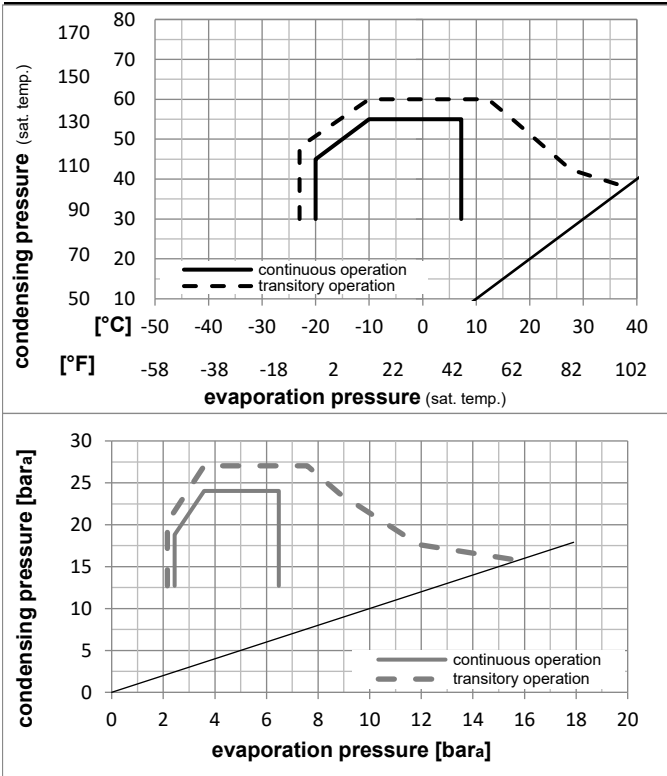

Components

a2	relay	117U6011
c	start capacitor (80μF)	117U5017
d	cord relief	103N1004
b	plastic cover	103N2008

Model

Designation **SC10MLX** **220-240V/50Hz** Conf. 4 Sales code: **104L2506**

Optimization + standard conditions

R448A, 220V/50Hz, CSIR, fan 3m/s,

	Evaporating pressure (saturation temperature)				Cooling capacity			COP	EER	P1	Power consumption		Ref. mass flow	
	pe	pc	RGT	Tliq	[W]	[Btu/h]	[kcal/h]				[W]	[A]		
[°C]	-7	54	35	46	815,0	2783	701,4	1,52	5,18	1,31	537,3	3,79	17,80	ASHRAE MBP
[°F]	20	130	95	115										
[°C]	-10	55	32	55	619,1	2114	532,8	1,22	4,17	1,05	507,0	3,68	15,16	cecomaf MBP
[°F]	14	131	90	131										
[°C]	-10	45	20	45	737,9	2520	635,1	1,57	5,35	1,35	471,0	3,54	17,26	EN12900 MBP
[°F]	14	113	68	113										
[°C]	-7	49	18	49	785,8	2684	676,2	1,53	5,22	1,32	513,8	3,70	19,54	ARI540 MBP
[°F]	20	120	65	120										
[°C]	-10	45	32	45	767,9	2622	660,8	1,63	5,57	1,40	471,0	3,54	16,78	opt
[°F]	14	113	90	113										
[°C]	-25	45	32	45	361,9	1236	311,5	1,03	3,50	0,88	352,6	3,10	7,78	opt
[°F]	-13	113	90	113										

Performance tables

R448A, 220V/50Hz, CSIR, fan 3m/s,

	pe		Cooling capacity			COP	EER	P1	I	m	
	[°C]	[°F]	[W]	[Btu/h]	[kcal/h]						
[°C / °F]	-20	-4	472,9	1615	407,0	1,21	4,12	1,04	392,2	3,25	10,21
cond. pressure	-15	5	607,3	2074	522,6	1,41	4,81	1,21	431,6	3,40	13,19
pc= 45/113	-10	14	767,9	2622	660,8	1,63	5,57	1,40	471,0	3,54	16,78
return gas temp.	-7	20	889,6	3038	765,6	1,79	6,11	1,54	497,2	3,64	19,53
RGT= 32/90	-5	23	957,6	3270	824,1	1,87	6,40	1,61	510,7	3,69	21,08
liquid temp	0	32	1179,3	4027	1014,9	2,14	7,31	1,84	551,1	3,84	26,19
Tliq= 45/113	7,2	45	1560,5	5330	1343,0	2,55	8,72	2,20	610,9	4,06	35,20
[°C / °F]	-20	-4	368,0	1257	316,7	0,90	3,08	0,78	407,4	3,31	8,90
cond. pressure	-15	5	483,2	1650	415,8	1,06	3,61	0,91	457,6	3,49	11,75
pc= 55/131	-10	14	619,1	2114	532,8	1,22	4,17	1,05	507,0	3,68	15,16
return gas temp	-7	20	721,4	2464	620,9	1,34	4,57	1,15	539,3	3,80	17,76
RGT= 32/90	-5	23	778,5	2659	670,0	1,40	4,78	1,21	555,8	3,86	19,22
liquid temp	0	32	964,3	3293	829,9	1,60	5,45	1,37	604,4	4,04	24,05
Tliq= 55/131	7,2	45	1284,2	4386	1105,2	1,90	6,50	1,64	674,6	4,30	32,59

Model

Designation	SC10MLX	220-240V/50Hz	Conf. 5	Sales code:	104L2506
-------------	----------------	----------------------	----------------	-------------	-----------------

Configuration

Motorconfiguration	CSIR
Power supply (nominal)	220-240V/50Hz 1~
Refrigerant	R449A
Application	MBP
Voltage range	187-254V
Starting torque	HST
Approvals	

Electrical accessories / wiring diagram

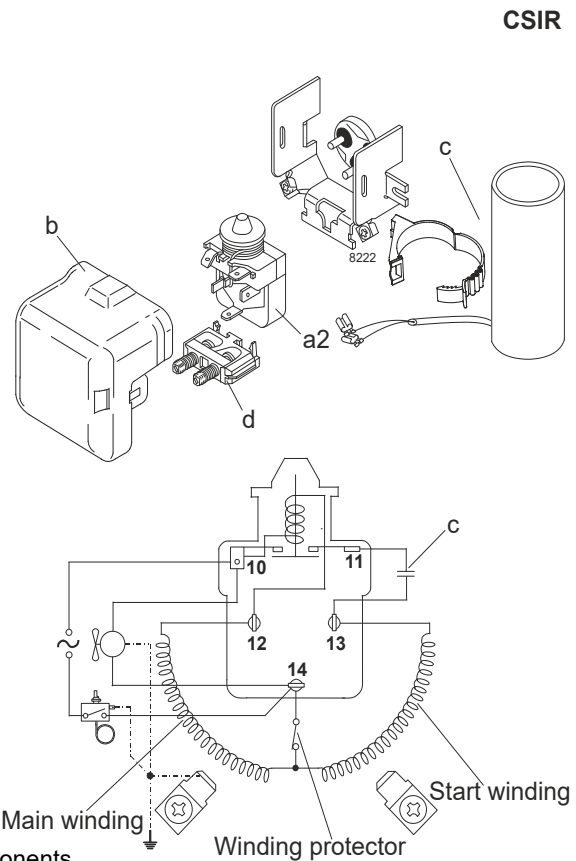

Ambient/ machine room temperatures minimum /maximum

Ambient temperature range:	10 - 38°C / 50 - 101°F
Machine room temperature range:	10 - 43°C / 50 - 110°F
Compressor cooling:	fan 3m/s

Operation Limits

Operation pressure range

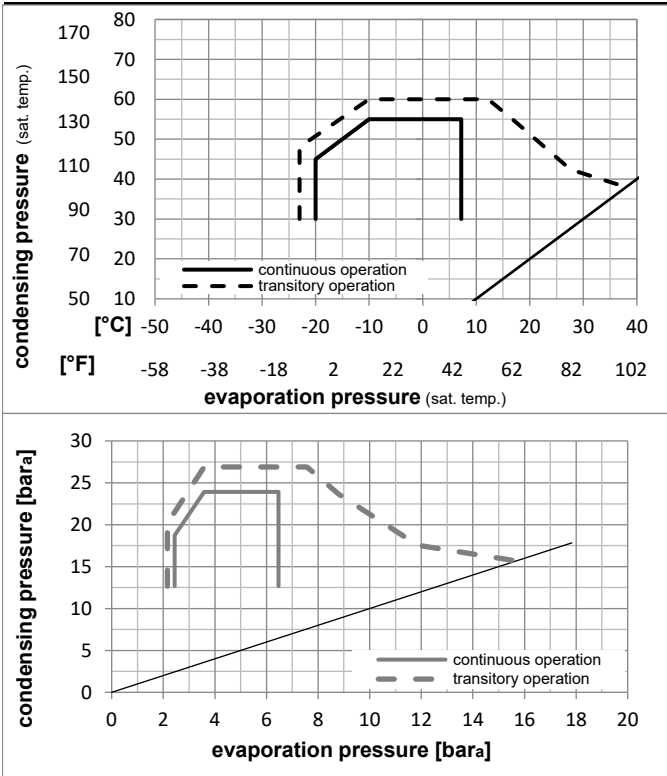

Components

a2	relay	117U6011
c	start capacitor (80μF)	117U5017
d	cord relief	103N1004
b	plastic cover	103N2008

Model

Designation **SC10MLX** **220-240V/50Hz** Conf. 5 Sales code: **104L2506**

Optimization + standard conditions

R449A, 220V/50Hz, CSIR, fan 3m/s,

	Evaporating pressure (saturation temperature)				Cooling capacity			COP	EER	P1	Power consumption		Ref. mass flow	
	pe	pc	RGT	Tliq	[W]	[Btu/h]	[kcal/h]				l	m		
[°C]	-7	54	35	46	810,6	2768	697,6	1,52	5,17	1,30	535,0	3,78	18,06	ASHRAE MBP
[°F]	20	130	95	115										
[°C]	-10	55	32	55	615,0	2100	529,3	1,22	4,16	1,05	504,9	3,67	15,38	cecomaf MBP
[°F]	14	131	90	131										
[°C]	-10	45	20	45	733,1	2504	630,9	1,56	5,34	1,34	469,3	3,54	17,51	EN12900 MBP
[°F]	14	113	68	113										
[°C]	-7	49	18	49	779,9	2664	671,2	1,52	5,21	1,31	511,7	3,69	19,82	ARI540 MBP
[°F]	20	120	65	120										
[°C]	-10	45	32	45	763,7	2608	657,2	1,63	5,56	1,40	469,3	3,54	17,02	opt
[°F]	14	113	90	113										
[°C]	-25	45	32	45	360,6	1231	310,3	1,02	3,50	0,88	351,9	3,10	7,91	opt
[°F]	-13	113	90	113										

Performance tables

R449A, 220V/50Hz, CSIR, fan 3m/s,

	pe		Cooling capacity			COP	EER	P1	l	m	
	[°C]	[°F]	[W]	[Btu/h]	[kcal/h]						
[°C / °F]	-20	-4	470,8	1608	405,2	1,20	4,11	1,04	391,2	3,25	10,37
cond. pressure	-15	5	604,2	2064	520,0	1,40	4,80	1,21	430,2	3,39	13,38
pc= 45/113	-10	14	763,7	2608	657,2	1,63	5,56	1,40	469,3	3,54	17,02
return gas temp.	-7	20	884,5	3021	761,2	1,79	6,10	1,54	495,2	3,63	19,81
RGT= 32/90	-5	23	952,0	3251	819,3	1,87	6,39	1,61	508,7	3,68	21,37
liquid temp	0	32	1172,0	4002	1008,6	2,14	7,30	1,84	548,6	3,83	26,55
Tliq= 45/113	7,2	45	1550,2	5294	1334,1	2,55	8,71	2,19	607,9	4,05	35,67
[°C / °F]	-20	-4	366,1	1250	315,0	0,90	3,08	0,78	406,3	3,30	9,04
cond. pressure	-15	5	480,3	1640	413,4	1,05	3,60	0,91	456,0	3,49	11,93
pc= 55/131	-10	14	615,0	2100	529,3	1,22	4,16	1,05	504,9	3,67	15,38
return gas temp	-7	20	716,5	2447	616,7	1,33	4,56	1,15	536,9	3,79	18,02
RGT= 32/90	-5	23	773,0	2640	665,3	1,40	4,77	1,20	553,3	3,85	19,50
liquid temp	0	32	957,2	3269	823,8	1,59	5,44	1,37	601,4	4,03	24,39
Tliq= 55/131	7,2	45	1274,0	4351	1096,5	1,90	6,49	1,63	670,7	4,28	33,04