

Model

Designation	SC10MNX	220-240V/50Hz 1~	Sales code:	104H8075
-------------	----------------	------------------	-------------	-----------------

Compressor design

Oil type	Polyolester	Refrigerant(s)	R290
Oil viscosity	22cST	Displacement	10,29cm ³ / 0,63cu.in
Oil quantity	500cm ³ / 16,9fl.oz	Compressors on pallet	80
Refr. charge - tech. limit	150g / 5,3oz		
Free gas volume comp.	1410cm ³ / 47,7fl.oz		
Weight	13,1kg / 28,9lbs		
Motor protection	1# internal		
Winding resistance main	5,13Ω (at 25°C)		
Winding resistance aux	13,51Ω (at 25°C)		
Max. winding temp.	125°C / 257°F		
Max. discharge temp.	130°C / 266°F		



General - Configurations with SC10MNX

Conf. 1

Motorconfiguration	CSIR
Power supply (nominal)	220-240V/50Hz
Number of phases	1
Voltage range	198-254V
Approvals	CCC, EAC, VDE
Starting torque	HST
Note	- / -

Applications with SC10MNX

Conf. 1

Refrigerant	R290
Application	MBP
System cooling	fan 3m/s
Hot gas defrost	OK
Long interval pull down	OK

Electrical data - Configurations with SC10MNX

Conf. 1

Starting device type	relay
Run capacitor	-/-
Start capacitor	80μF
LRA (locked rotor amps / 4s)	16,2A
RLA (rated load amps / 1s)	3,1A
Cut in current	16,2A

Model

Designation	SC10MNX	220-240V/50Hz 1~	Sales code:	104H8075
-------------	----------------	------------------	-------------	-----------------

Compressor dimensions

Housing	A Height	209mm / 8,23in
	B Height	203mm / 7,99in
	C Length shell	218mm / 8,58in
	D Length w. cover	255mm / 10,04in
	E Width	151mm / 5,94in

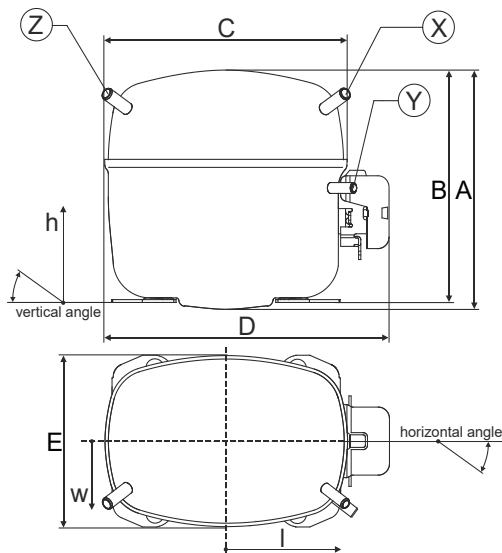

Connectors		Suction	Discharge	Process
		X	Y	Z
Diameter	[mm]	øi 8,11-8,29	øi 6,11-6,29	øi 6,11-6,29
(i:inside, o:outside)	[in]	øi 0,32-0,33	øi 0,24-0,25	øi 0,24-0,25
Material		copper	copper	copper
Horizontal angle	±2°	37°	37°	143°
Vertical angle	±2°	30°	0°	150°
Position l/h/w	[mm]	107/183/55	115/100/63	-107/183/55
	[in]	4,2/7,2/2,2	4,5/3,9/2,5	-4,2/7,2/2,2
Straight tube l.	[mm]	12	12	12
	[in]	0,5	0,5	0,5

Compressor fixation

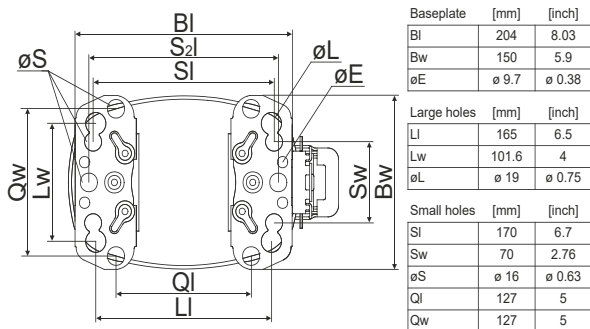

Bolt joint

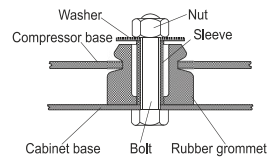

Snap-on

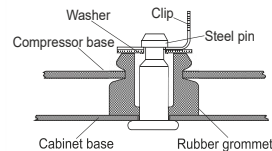

Mounting accessories	one comp.	multi pack
Bolt joint M6 ø16mm	118-1917	118-1918
Bolt joint ø1/4" ø16mm	118-1946	
Bolt joint ø1/4" ø19mm	118-1949	
Snap-on ø7,3 ø16mm	118-1947	118-1919

Application notes

Provision for PE Grounding is located at the PE Stamp on the compressor

Model

Designation	SC10MNX	220-240V/50Hz	Conf. 1	Sales code:	104H8075
-------------	----------------	----------------------	---------	-------------	-----------------

Configuration

Motorconfiguration	CSIR
Power supply (nominal)	220-240V/50Hz 1~
Refrigerant	R290
Application	MBP
Voltage range	198-254V
Starting torque	HST
Approvals	CCC
	EAC
	VDE

Electrical accessories / wiring diagram

CSIR

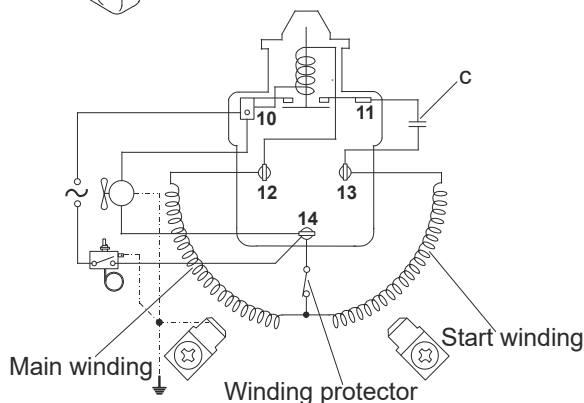
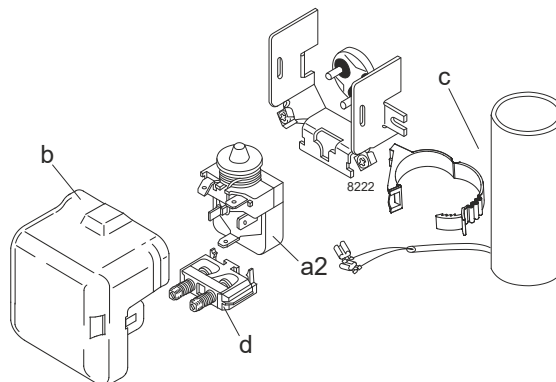

Ambient/ machine room temperatures minimum /maximum

Ambient temperature range: 10 - 43°C / 50 - 110°F

Machine room temperature range: 10 - 48°C / 50 - 119°F

Compressor cooling: fan 3m/s

Operation Limits

Operation pressure range

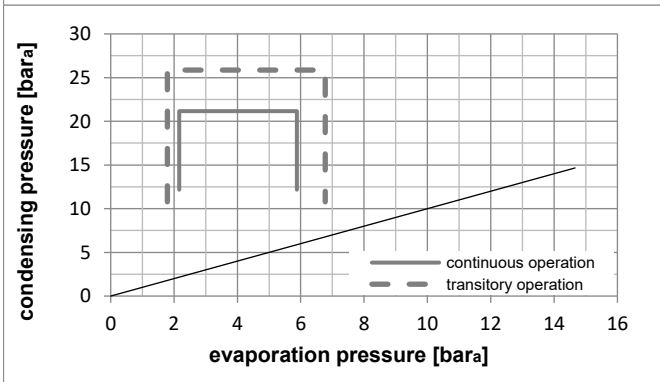
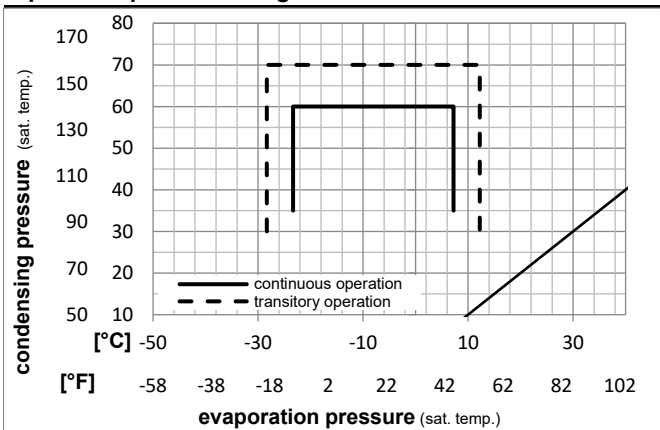

Components

a2	relay	117U7005
c	start capacitor (80µF)	117U5017
d	cord relief	103N1004
b	plastic cover	103N2009

Alternative components

a2	relay	117U7005
c	start capacitor (80µF)	117U5017
d	cord relief	103N1004
b	plastic cover	103N2008

Model

Designation **SC10MNX** **220-240V/50Hz** Conf. 1 Sales code: **104H8075**

Optimization + standard conditions

R290, 220V/50Hz, CSIR, fan 3m/s, CCC, EAC, VDE

Evaporating pressure (saturation temperature)				Condensing pressure (saturation temperature)			Return gas temp.			Liquid temp.			Cooling capacity			COP	EER	Power consumption			Ref. mass flow m	ASHRAE MBP
pe	pc	RGT	Tliq	[W]	[Btu/h]	[kcal/h]	[W/W]	[Btu/Wh]	[kcal/Wh]	P1	I	[kg/h]										
[°C]	[°F]	[°C]	[°F]	[W]	[Btu/h]	[kcal/h]	[W/W]	[Btu/Wh]	[kcal/Wh]	[W]	[A]	[kg/h]										
-7	54	35	46	766,7	2618	659,8	1,70	5,80	1,46	451,4	2,83	8,75	ASHRAE MBP									
20	130	95	115																			
-10	55	32	55	593,3	2026	510,6	1,38	4,71	1,19	429,8	2,76	7,50	cecomaf MBP									
14	131	90	131																			
-10	45	20	45	686,5	2344	590,8	1,71	5,85	1,48	400,4	2,67	8,43	EN12900 MBP									
14	113	68	113																			
-7	49	18	49	734,0	2507	631,7	1,70	5,82	1,47	430,8	2,77	9,53	ARI540 MBP									
20	120	65	120																			
-10	45	32	45	714,6	2441	615,0	1,78	6,09	1,54	400,4	2,67	8,18	opt									
14	113	90	113																			
-25	45	32	45	327,7	1119	282,0	1,12	3,84	0,97	291,8	2,39	3,70	opt									
-13	113	90	113																			

Performance tables

R290, 220V/50Hz, CSIR, fan 3m/s, CCC, EAC, VDE

	pe		Cooling capacity			COP	EER		P1	I	m
	[°C]	[°F]	[W]	[Btu/h]	[kcal/h]	[W/W]	[Btu/Wh]	[kcal/Wh]	[W]	[A]	[kg/h]
[°C / °F]	-23	-10	363,8	1242	313,1	1,18	4,03	1,02	308,4	2,42	4,11
cond. pressure	-20	-4	439,2	1500	377,9	1,30	4,45	1,12	337,1	2,49	4,97
pc= 45/113	-15	5	567,4	1938	488,4	1,52	5,20	1,31	372,8	2,58	6,46
return gas temp.	-10	14	714,6	2441	615,0	1,78	6,09	1,54	400,4	2,67	8,18
RGT= 32/90	-5	23	882,8	3015	759,8	2,09	7,15	1,80	421,7	2,74	10,16
liquid temp	0	32	1074,1	3668	924,4	2,45	8,37	2,11	438,4	2,82	12,46
Tliq= 45/113	7,2	45	1394,5	4762	1200,1	3,05	10,40	2,62	457,7	2,91	16,38
[°C / °F]	-23	-10	282,6	965	243,2	0,96	3,29	0,83	293,1	2,43	3,52
cond. pressure	-20	-4	349,7	1194	300,9	1,05	3,57	0,90	334,4	2,51	4,37
pc= 55/131	-15	5	463,3	1582	398,7	1,20	4,09	1,03	387,2	2,64	5,83
return gas temp	-10	14	593,3	2026	510,6	1,38	4,71	1,19	429,8	2,76	7,50
RGT= 32/90	-5	23	741,7	2533	638,3	1,60	5,46	1,38	463,9	2,87	9,45
liquid temp	0	32	910,6	3110	783,6	1,85	6,33	1,60	491,0	2,98	11,70
Tliq= 55/131	7,2	45	1194,1	4078	1027,7	2,29	7,82	1,97	521,6	3,12	15,56