

Model

Designation	SC12CLX.2	220-240V/50Hz 1~ 220-240V/60Hz 1~	Sales code:	104L2697
-------------	------------------	-----------------------------------	-------------	-----------------

Compressor design

Oil type	Polyolester	Refrigerant(s)	R404A, R452A, R507
Oil viscosity	32cST	Displacement	12,87cm ³ / 0,79cu.in
Oil quantity	499cm ³ / 16,9fl.oz	Compressors on pallet	80
Refr. charge - tech. limit	1300g / 45,9oz		
Free gas volume comp.	1510cm ³ / 51,1fl.oz		
Weight	13,7kg / 30,2lbs		
Motor protection	1# internal		
Winding resistance main	3,7Ω (at 25°C)		
Winding resistance aux	14Ω (at 25°C)		
Max. winding temp.	125°C / 257°F		
Max. discharge temp.	130°C / 266°F		



General - Configurations with SC12CLX.2

	Conf. 1	Conf. 2	Conf. 3	Conf. 4
Motorconfiguration	CSIR	CSIR	CSIR	CSIR
Power supply (nominal)	220-240V/50Hz	208-230V/60Hz	220-240V/50Hz	208-230V/60Hz
Number of phases	1	1	1	1
Voltage range	198-254V	198-254V	198-254V	198-254V
Approvals	UL, VDE, CCC, KC, EAC	UL, VDE, CCC, KC, EAC	UL, VDE, CCC, KC, EAC	UL, VDE, CCC, KC, EAC
Starting torque	HST	HST	HST	HST
Note	- / -			

Applications with SC12CLX.2

	Conf. 1	Conf. 2	Conf. 3	Conf. 4
Refrigerant	R404A	R404A	R452A	R452A
Application	LBP	LBP	LBP	LBP
System cooling	fan 3m/s	fan 3m/s	fan 3m/s	fan 3m/s
Hot gas defrost	OK	OK	OK	OK
Long interval pull down	OK	OK	OK	OK

Electrical data - Configurations with SC12CLX.2

	Conf. 1	Conf. 2	Conf. 3	Conf. 4
Starting device type	relay	relay	relay	relay
Run capacitor	- / -	- / -	- / -	- / -
Start capacitor	80μF	80μF	80μF	80μF
LRA (locked rotor amps / 4s)	23,4A	23,4A	23,4A	23,4A
RLA (rated load amps / 1s)	4,3A	4,3A	4,3A	4,3A
Cut in current	23,4A	23,4A	23,4A	23,4A

Model

Designation

SC12CLX.2

220-240V/50Hz 1~ 220-240V/60Hz 1~

Sales code:

104L2697

Compressor dimensions

Housing	A Height	219mm / 8,62in
	B Height	213mm / 8,39in
	C Length shell	218mm / 8,58in
	D Length w. cover	255mm / 10,04in
	E Width	151mm / 5,94in

Connectors		Suction	Discharge	Process
		X	Y	Z
Diameter	[mm]	øi 8,11-8,29	øi 6,11-6,29	øi 6,11-6,29
	(i:inside, o:outside) [in]	øi 0,32-0,33	øi 0,24-0,25	øi 0,24-0,25
Material		copper	copper	copper
Horizontal angle	±2°	37°	37°	143°
Vertical angle	±2°	30°	0°	150°
Position l/h/w	[mm]	107/193/55	115/110/63	-107/193/55
	[in]	4,2/7,6/2,2	4,5/4,3/2,5	-4,2/7,6/2,2
Straight tube l.	[mm]	12	12	12
	[in]	0,5	0,5	0,5

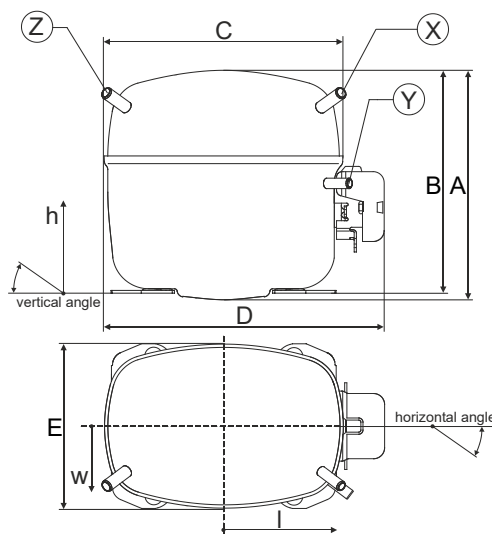

Compressor fixation

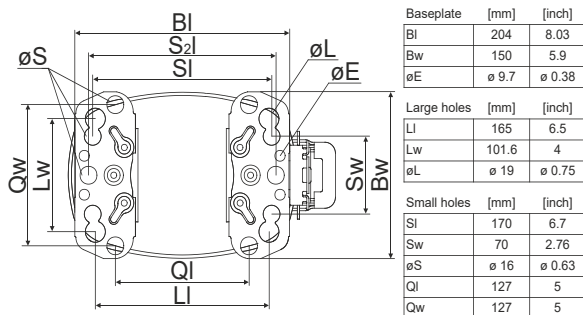

Bolt joint



Snap-on



Mounting accessories

	one comp.	multi pack
Bolt joint M6 ø16mm	118-1917	118-1918
Bolt joint ø1/4" ø16mm	118-1946	
Bolt joint ø1/4" ø19mm	118-1949	
Snap-on ø7,3 ø16mm	118-1947	118-1919

Application notes

LRA value on compressor label and datasheet may differ due to different test conditions for UL approval.

Provision for PE Grounding is located at the PE Stamp on the compressor

Model

Designation	SC12CLX.2	220-240V/50Hz	Conf. 1	Sales code:	104L2697
-------------	------------------	----------------------	----------------	-------------	-----------------

Configuration

Motorconfiguration	CSIR
Power supply (nominal)	220-240V/50Hz 1~
Refrigerant	R404A
Application	LBP
Voltage range	198-254V
Starting torque	HST
Approvals	UL VDE CCC KC EAC

Electrical accessories / wiring diagram

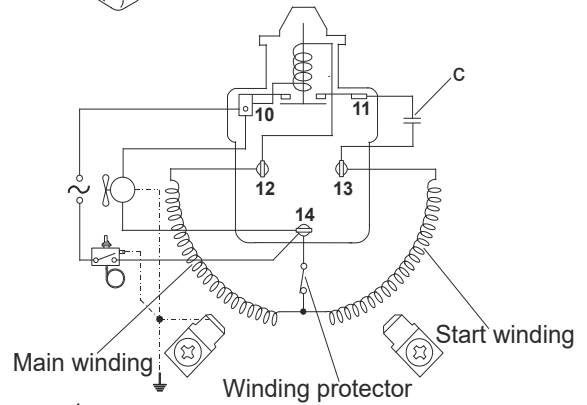
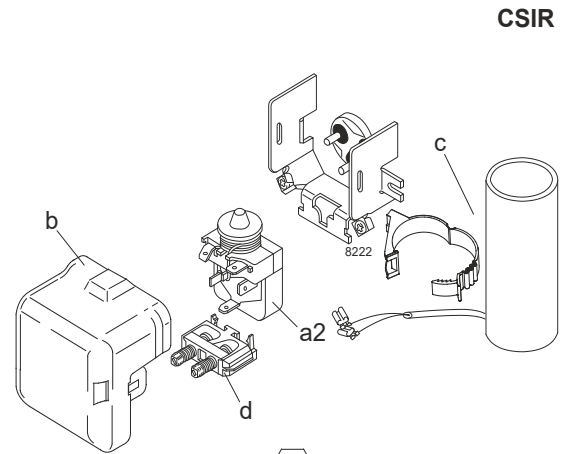

Ambient/ machine room temperatures minimum /maximum

Ambient temperature range:	10 - 38°C / 50 - 101°F
Machine room temperature range:	10 - 43°C / 50 - 110°F
Compressor cooling:	fan 3m/s

Operation Limits

Operation pressure range

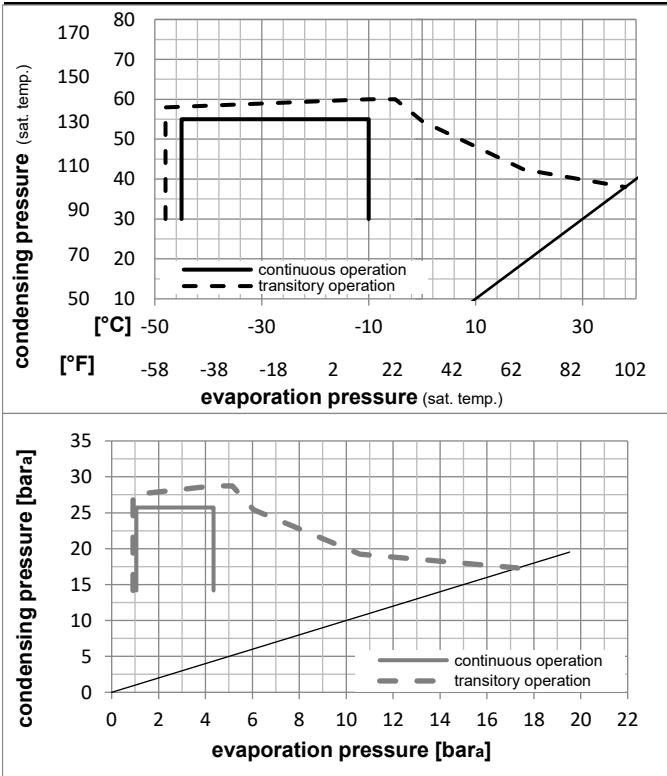

Components

a2	relay	117U6019
c	start capacitor (80μF)	117U5017
d	cord relief	103N1004
b	plastic cover	103N2008

Alternative components

a2	relay	117U6019
c	start capacitor i-pack 40# (80μF)	117U5067
d	cord relief	103N1004
b	plastic cover	103N2008

Model

Designation **SC12CLX.2** **220-240V/50Hz** Conf. 1 Sales code: **104L2697**

Optimization + standard conditions

R404A, 220V/50Hz, CSIR, fan 3m/s, UL, VDE, CCC, KC, EAC

	Evaporating pressure (saturation temperature)				Condensing pressure (saturation temperature)			COP	EER	P1	Power consumption		Ref. mass flow			
	pe	pc	RGT	Tliq	Return gas temp.	Liquid temp.	Cooling capacity				I	m				
	[°C]	[°C]	[°C]	[°C]	[°C]	[°C]	[W]	[Btu/h]	[kcal/h]	[W/W]	[Btu/Wh]	[kcal/Wh]	[W]	[A]	[kg/h]	
	-23	54	32	32			591,9	2022	509,4	1,15	3,92	0,99	515,6	3,35	13,79	ASHRAE LBP
	[°F]	-10	130	90	90											
	-25	55	32	55			398,5	1361	342,9	0,80	2,75	0,69	495,0	3,28	12,45	cecomaf LBP
	[°F]	-13	131	90	131											
	-35	40	20	40			321,6	1098	276,7	0,89	3,03	0,76	362,6	3,02	8,74	EN12900 LBP
	[°F]	-31	104	68	104											
	-23	49	4,4	49			447,2	1527	384,9	0,89	3,04	0,77	503,0	3,35	15,83	ARI540 LBP
	[°F]	-10	120	40	120											
	-23	41	32	32			684,3	2337	588,9	1,41	4,81	1,21	485,6	3,33	15,95	AHAM LBP
	[°F]	-10	105	90	90											
	-35	45	32	45			293,7	1003	252,8	0,81	2,75	0,69	364,5	3,00	7,85	opt
	[°F]	-31	113	90	113											

Performance tables

R404A, 220V/50Hz, CSIR, fan 3m/s, UL, VDE, CCC, KC, EAC

	pe		Cooling capacity			COP	EER	P1	I	m	
	[°C]	[°F]	[W]	[Btu/h]	[kcal/h]	[W/W]	[Btu/Wh]	[kcal/Wh]	[W]	[A]	[kg/h]
[°C / °F]	-45	-49	130,2	445	112,1	0,51	1,76	0,44	253,2	2,77	3,46
cond. pressure	-35	-31	293,7	1003	252,8	0,81	2,75	0,69	364,5	3,00	7,85
pc= 45/113	-30	-22	398,7	1362	343,1	0,95	3,25	0,82	419,5	3,13	10,70
return gas temp.	-25	-13	522,2	1783	449,4	1,10	3,75	0,95	475,5	3,29	14,09
RGT= 32/90	-20	-4	666,4	2276	573,5	1,25	4,27	1,08	533,4	3,46	18,08
liquid temp	-15	5	833,5	2847	717,3	1,40	4,79	1,21	594,4	3,65	22,77
Tliq= 45/113	-10	14	1025,9	3503	882,9	1,56	5,31	1,34	659,4	3,86	28,25
[°C / °F]	-45	-49	62,4	213	53,7	0,27	0,93	0,23	230,3	2,64	1,92
cond. pressure	-35	-31	204,1	697	175,6	0,56	1,91	0,48	364,9	2,93	6,31
pc= 55/131	-30	-22	293,5	1003	252,6	0,68	2,33	0,59	430,0	3,10	9,12
return gas temp	-25	-13	398,5	1361	342,9	0,80	2,75	0,69	495,0	3,28	12,45
RGT= 32/90	-20	-4	521,0	1779	448,4	0,93	3,17	0,80	561,0	3,49	16,39
liquid temp	-15	5	663,4	2266	571,0	1,05	3,60	0,91	629,1	3,71	21,04
Tliq= 55/131	-10	14	828,0	2828	712,6	1,18	4,04	1,02	700,2	3,95	26,51

Model

Designation	SC12CLX.2	208-230V/60Hz	Conf. 2	Sales code:	104L2697
-------------	------------------	----------------------	----------------	-------------	-----------------

Configuration

Motorconfiguration	CSIR
Power supply (nominal)	208-230V/60Hz 1~
Refrigerant	R404A
Application	LBP
Voltage range	198-254V
Starting torque	HST
Approvals	UL VDE CCC KC EAC

Electrical accessories / wiring diagram

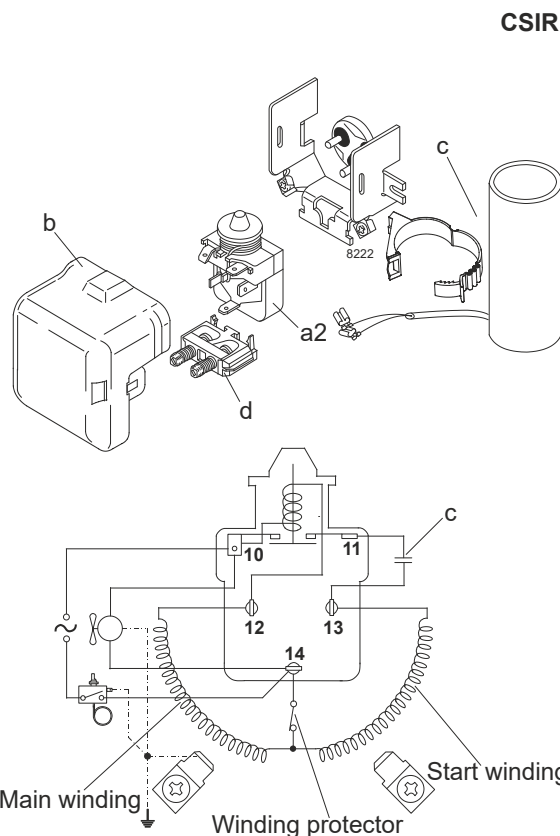

Ambient/ machine room temperatures minimum /maximum

Ambient temperature range: 10 - 38°C / 50 - 101°F

Machine room temperature range: 10 - 43°C / 50 - 110°F

Compressor cooling: fan 3m/s

Operation Limits

Operation pressure range

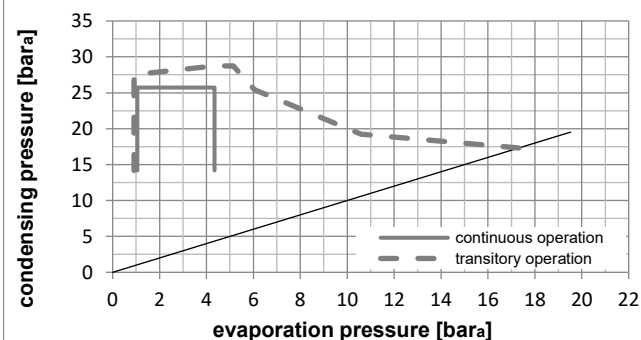
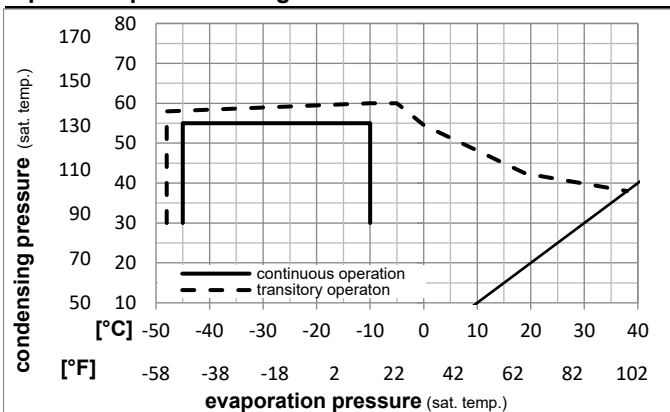

Components

a2	relay	117U6019
c	start capacitor (80μF)	117U5017
d	cord relief	103N1004
b	plastic cover	103N2008

Alternative components

a2	relay	117U6019
c	start capacitor i-pack 40# (80μF)	117U5067
d	cord relief	103N1004
b	plastic cover	103N2008

Model

Designation **SC12CLX.2** **208-230V/60Hz** Conf. 2 Sales code: **104L2697**

Optimization + standard conditions

R404A, 220V/60Hz, CSIR, fan 3m/s, UL, VDE, CCC, KC, EAC

		Evaporating pressure (saturation temperature)				Condensing pressure (saturation temperature)			Return gas temp.			Liquid temp.			Cooling capacity			COP	EER	Power consumption			
		pe	pc	RGT	Tliq	[W]	[Btu/h]	[kcal/h]	[W/W]	[Btu/Wh]	[kcal/Wh]	P1	I	m	[W]	[A]	[kg/h]						
[°C]	[°F]	[°C]	[°F]	[°C]	[°F]																		
-23	54	32	32	705,2	2408	606,9	1,19	4,07	1,03	592,0	3,09	16,43	ASHRAE LBP										
-10	130	90	90																				
-25	55	32	55	472,6	1614	406,7	0,84	2,85	0,72	565,6	3,00	14,77	cecomaf LBP										
-13	131	90	131																				
-35	40	20	40	378,5	1293	325,7	0,96	3,27	0,82	395,7	2,62	10,28	EN12900 LBP										
-31	104	68	104																				
-23	49	4,4	49	535,6	1829	461,0	0,93	3,18	0,80	575,8	3,09	18,96	ARI540 LBP										
-10	120	40	120																				
-23	41	32	32	824,1	2814	709,2	1,49	5,08	1,28	553,5	3,07	19,20	AHAM LBP										
-10	105	90	90																				
-35	45	32	45	343,1	1172	295,3	0,86	2,94	0,74	398,1	2,60	9,17	opt										
-31	113	90	113																				

Performance tables

R404A, 220V/60Hz, CSIR, fan 3m/s, UL, VDE, CCC, KC, EAC

	pe		Cooling capacity			COP	EER	P1	I	m	
	[°C]	[°F]	[W]	[Btu/h]	[kcal/h]	[W/W]	[Btu/Wh]	[kcal/Wh]	[W]	[A]	[kg/h]
[°C / °F]	-45	-49	141,0	482	121,3	0,55	1,89	0,48	255,2	2,28	3,75
cond. pressure	-35	-31	343,1	1172	295,3	0,86	2,94	0,74	398,1	2,60	9,17
pc= 45/113	-30	-22	472,9	1615	407,0	1,01	3,45	0,87	468,7	2,79	12,70
return gas temp.	-25	-13	625,6	2137	538,4	1,16	3,95	1,00	540,6	3,01	16,88
RGT= 32/90	-20	-4	803,9	2745	691,8	1,31	4,46	1,12	615,0	3,25	21,81
liquid temp	-15	5	1010,5	3451	869,7	1,46	4,98	1,25	693,2	3,52	27,60
Tliq= 45/113	-10	14	1248,3	4263	1074,3	1,61	5,49	1,38	776,8	3,81	34,38
[°C / °F]	-45	-49	57,1	195	49,2	0,25	0,86	0,22	225,7	2,10	1,75
cond. pressure	-35	-31	232,3	793	199,9	0,58	1,99	0,50	398,5	2,50	7,18
pc= 55/131	-30	-22	342,9	1171	295,1	0,71	2,43	0,61	482,1	2,74	10,66
return gas temp	-25	-13	472,6	1614	406,7	0,84	2,85	0,72	565,6	3,00	14,77
RGT= 32/90	-20	-4	624,1	2132	537,1	0,96	3,28	0,83	650,4	3,28	19,64
liquid temp	-15	5	800,2	2733	688,7	1,08	3,70	0,93	737,8	3,59	25,38
Tliq= 55/131	-10	14	1003,7	3428	863,8	1,21	4,13	1,04	829,1	3,92	32,13

Model

Designation	SC12CLX.2	220-240V/50Hz	Conf. 3	Sales code:	104L2697
-------------	------------------	----------------------	----------------	-------------	-----------------

Configuration

Motorconfiguration	CSIR
Power supply (nominal)	220-240V/50Hz 1~
Refrigerant	R452A
Application	LBP
Voltage range	198-254V
Starting torque	HST
Approvals	UL VDE CCC KC EAC

Electrical accessories / wiring diagram

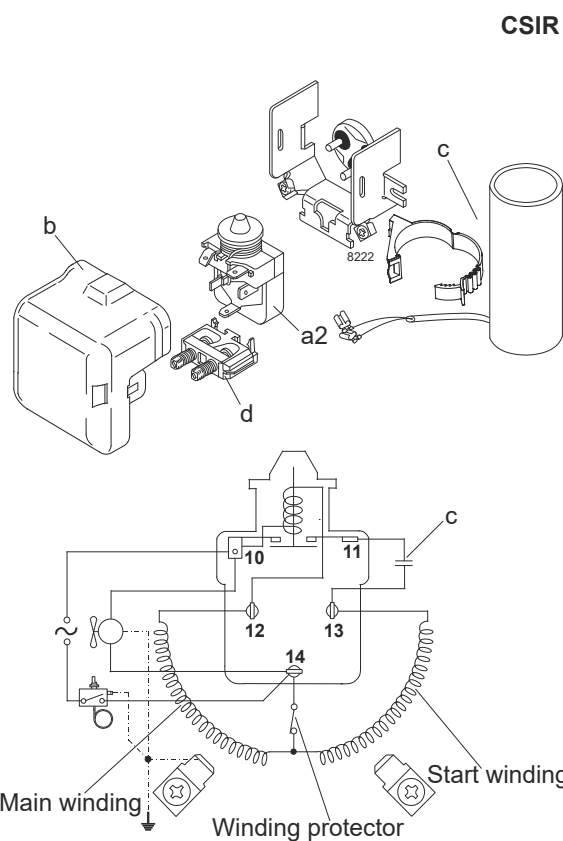

Ambient/ machine room temperatures minimum /maximum

Ambient temperature range:	10 - 38°C / 50 - 101°F
Machine room temperature range:	10 - 43°C / 50 - 110°F
Compressor cooling:	fan 3m/s

Operation Limits

Operation pressure range

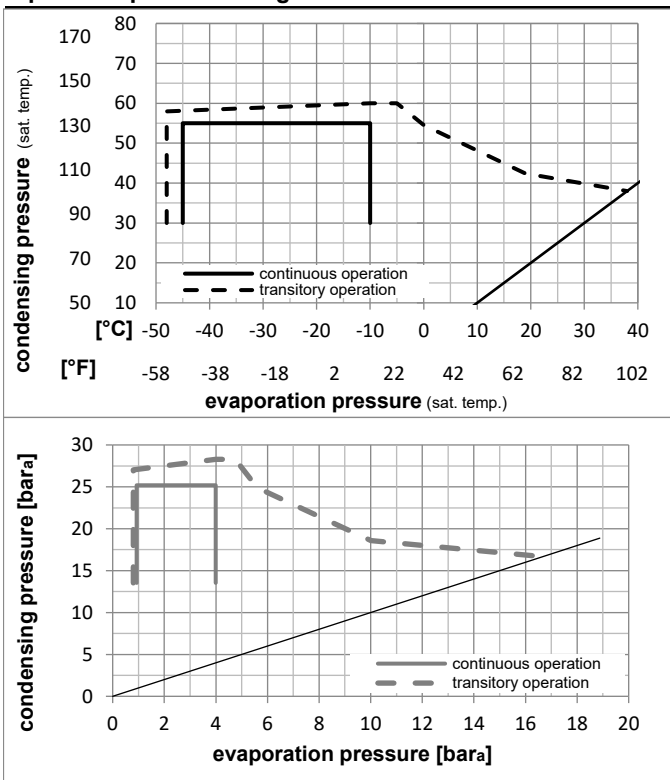

Components

a2	relay	117U6019
c	start capacitor (80μF)	117U5017
d	cord relief	103N1004
b	plastic cover	103N2008

Alternative components

a2	relay	117U6019
c	start capacitor i-pack 40# (80μF)	117U5067
d	cord relief	103N1004
b	plastic cover	103N2008

Model

Designation **SC12CLX.2** **220-240V/50Hz** Conf. 3 Sales code: **104L2697**

Optimization + standard conditions

R452A, 220V/50Hz, CSIR, fan 3m/s, UL, VDE, CCC, KC, EAC

	Evaporating pressure (saturation temperature)				Cooling capacity			COP	EER	P1	Power consumption			ASHRAE LBP
	pe	pc	RGT	Tliq	[W]	[Btu/h]	[kcal/h]				[W]	[A]	l	
[°C]	-23	54	32	32	541,3	1849	465,8	1,13	3,87	0,97	477,9	3,31	13,01	
[°F]	-10	130	90	90										
[°C]	-25	55	32	55	367,3	1254	316,1	0,80	2,74	0,69	457,2	3,25	11,69	cecomaf LBP
[°F]	-13	131	90	131										
[°C]	-35	40	20	40	290,0	990	249,6	0,88	2,99	0,75	331,3	2,87	8,10	EN12900 LBP
[°F]	-31	104	68	104										
[°C]	-23	49	4,4	49	415,5	1419	357,6	0,89	3,04	0,76	467,5	3,28	14,93	ARI540 LBP
[°F]	-10	120	40	120										
[°C]	-23	41	32	32	629,7	2151	542,0	1,39	4,75	1,20	452,6	3,24	15,14	AHAM LBP
[°F]	-10	105	90	90										
[°C]	-35	45	32	45	264,1	902	227,3	0,80	2,72	0,69	331,7	2,88	7,25	opt
[°F]	-31	113	90	113										

Performance tables

R452A, 220V/50Hz, CSIR, fan 3m/s, UL, VDE, CCC, KC, EAC

	pe		Cooling capacity			COP	EER	P1	l	m	
	[°C]	[°F]	[W]	[Btu/h]	[kcal/h]						[W/W]
[°C / °F]	-45	-49	110,7	378	95,3	0,50	1,71	0,43	221,3	2,55	3,02
cond. pressure	-35	-31	264,1	902	227,3	0,80	2,72	0,69	331,7	2,88	7,25
pc= 45/113	-30	-22	363,4	1241	312,7	0,94	3,21	0,81	386,1	3,04	10,01
return gas temp.	-25	-13	480,9	1643	413,9	1,09	3,72	0,94	441,5	3,21	13,30
RGT= 32/90	-20	-4	619,2	2115	532,9	1,24	4,24	1,07	498,9	3,38	17,22
liquid temp	-15	5	780,5	2666	671,7	1,40	4,77	1,20	559,4	3,56	21,83
Tliq= 45/113	-10	14	967,3	3304	832,5	1,55	5,29	1,33	624,1	3,75	27,25
[°C / °F]	-45	-49	49,2	168	42,3	0,25	0,86	0,22	195,0	2,47	1,54
cond. pressure	-35	-31	182,2	622	156,8	0,56	1,90	0,48	328,2	2,87	5,75
pc= 55/131	-30	-22	267,0	912	229,8	0,68	2,32	0,59	392,7	3,06	8,46
return gas temp	-25	-13	367,3	1254	316,1	0,80	2,74	0,69	457,2	3,25	11,69
RGT= 32/90	-20	-4	485,4	1658	417,8	0,93	3,17	0,80	522,8	3,45	15,54
liquid temp	-15	5	623,8	2130	536,9	1,06	3,61	0,91	590,7	3,65	20,11
Tliq= 55/131	-10	14	784,8	2680	675,4	1,19	4,05	1,02	661,8	3,87	25,51

Model

Designation	SC12CLX.2	208-230V/60Hz	Conf. 4	Sales code:	104L2697
-------------	------------------	----------------------	----------------	-------------	-----------------

Configuration

Motorconfiguration	CSIR
Power supply (nominal)	208-230V/60Hz 1~
Refrigerant	R452A
Application	LBP
Voltage range	198-254V
Starting torque	HST
Approvals	UL VDE CCC KC EAC

Electrical accessories / wiring diagram

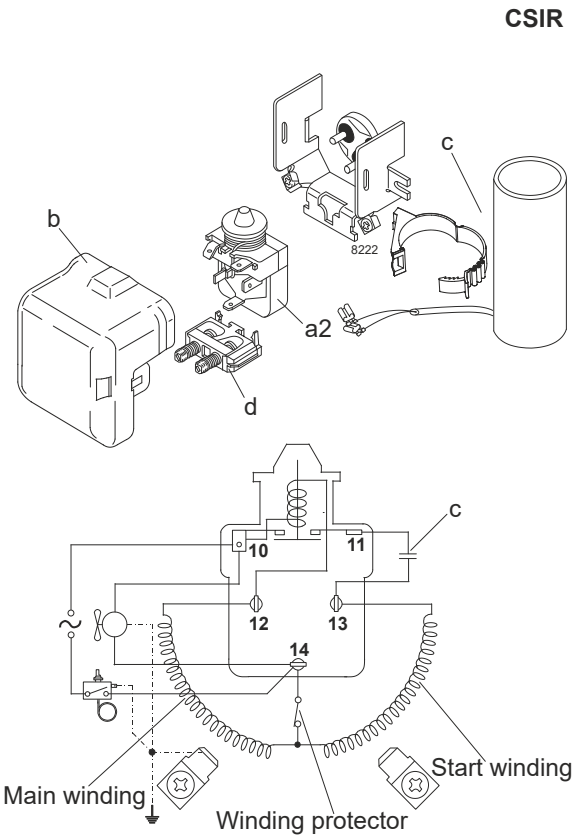

Ambient/ machine room temperatures minimum /maximum

Ambient temperature range:	10 - 38°C / 50 - 101°F
Machine room temperature range:	10 - 43°C / 50 - 110°F
Compressor cooling:	fan 3m/s

Operation Limits

Operation pressure range

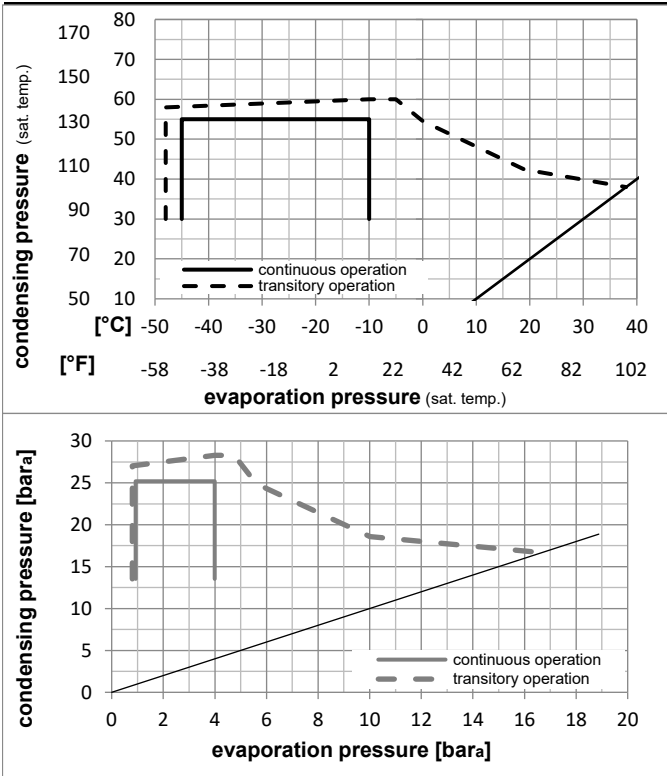

Components

a2	relay	117U6019
c	start capacitor (80μF)	117U5017
d	cord relief	103N1004
b	plastic cover	103N2008

Alternative components

a2	relay	117U6019
c	start capacitor i-pack 40# (80μF)	117U5067
d	cord relief	103N1004
b	plastic cover	103N2008

Model

Designation **SC12CLX.2** **208-230V/60Hz** Conf. 4 Sales code: **104L2697**

Optimization + standard conditions

R452A, 220V/60Hz, CSIR, fan 3m/s, UL, VDE, CCC, KC, EAC

		Evaporating pressure (saturation temperature)				Condensing pressure (saturation temperature)						Power consumption			
		Return gas temp.		Liquid temp.		Cooling capacity		COP	EER		P1	I	Ref. mass flow		
		pe	pc	RGT	Tliq	[W]	[Btu/h]	[kcal/h]	[W/W]	[Btu/Wh]	[kcal/Wh]	[W]	[A]	[kg/h]	
[°C]	[°F]	[°C]	[°F]	[°C]	[°F]										
-23	-10	54	130	32	90	643,9	2199	554,2	1,17	3,99	1,00	551,6	3,08	15,48	ASHRAE LBP
-25	-13	55	131	32	90	435,1	1486	374,4	0,83	2,83	0,71	525,3	3,00	13,85	cecomaf LBP
-35	-31	40	104	20	68	340,8	1164	293,3	0,94	3,19	0,80	364,5	2,47	9,52	EN12900 LBP
-23	-10	49	120	4,4	40	497,0	1697	427,7	0,92	3,16	0,80	537,9	3,04	17,86	ARI540 LBP
-23	-10	41	105	32	90	757,5	2587	651,9	1,46	4,99	1,26	518,3	2,98	18,21	AHAM LBP
-35	-31	45	113	32	90	308,1	1052	265,1	0,84	2,88	0,73	365,4	2,47	8,45	opt

Performance tables

R452A, 220V/60Hz, CSIR, fan 3m/s, UL, VDE, CCC, KC, EAC

	pe		Cooling capacity			COP	EER	P1	I	m	
	[°C]	[°F]	[W]	[Btu/h]	[kcal/h]	[W/W]	[Btu/Wh]	[kcal/Wh]	[W]	[A]	[kg/h]
[°C / °F]	-45	-49	119,5	408	102,8	0,53	1,80	0,45	227,2	2,01	3,26
cond. pressure	-35	-31	308,1	1052	265,1	0,84	2,88	0,73	365,4	2,47	8,45
pc= 45/113	-30	-22	430,5	1470	370,4	0,99	3,39	0,85	434,2	2,70	11,86
return gas temp.	-25	-13	575,5	1965	495,2	1,14	3,90	0,98	504,4	2,93	15,92
RGT= 32/90	-20	-4	746,0	2548	642,0	1,29	4,41	1,11	577,6	3,17	20,74
liquid temp	-15	5	945,0	3227	813,2	1,44	4,93	1,24	655,0	3,43	26,43
Tliq= 45/113	-10	14	1175,3	4014	1011,5	1,59	5,44	1,37	738,1	3,70	33,11
[°C / °F]	-45	-49	44,2	151	38,0	0,23	0,77	0,20	195,0	1,91	1,38
cond. pressure	-35	-31	207,2	708	178,3	0,57	1,95	0,49	362,0	2,46	6,53
pc= 55/131	-30	-22	311,6	1064	268,1	0,70	2,40	0,60	443,4	2,73	9,87
return gas temp	-25	-13	435,1	1486	374,4	0,83	2,83	0,71	525,3	3,00	13,85
RGT= 32/90	-20	-4	580,7	1983	499,7	0,95	3,26	0,82	608,9	3,27	18,59
liquid temp	-15	5	751,2	2565	646,5	1,08	3,69	0,93	695,7	3,56	24,21
Tliq= 55/131	-10	14	949,6	3243	817,3	1,21	4,12	1,04	787,0	3,86	30,86