

Model

Designation	SC12CNX.2	115V/60Hz 1~	Sales code:	104H7270
-------------	------------------	--------------	-------------	-----------------

Compressor design

Oil type	Polyolester	Refrigerant(s)	R290
Oil viscosity	22cST	Displacement	12,87cm ³ / 0,79cu.in
Oil quantity	500cm ³ / 16,9fl.oz	Compressors on pallet	80
Refr. charge - tech. limit	500g / 17,6oz		
Free gas volume comp.	1510cm ³ / 51,1fl.oz		
Weight	13,2kg / 29,1lbs		
Motor protection	1# internal		
Winding resistance main	0,98Ω (at 25°C)		
Winding resistance aux	4,18Ω (at 25°C)		
Max. winding temp.	125°C / 257°F		
Max. discharge temp.	130°C / 266°F		



General - Configurations with SC12CNX.2

	Conf. 1
Motorconfiguration	CSIR
Power supply (nominal)	115V/60Hz
Number of phases	1
Voltage range	95-135V
Approvals	UL, VDE, EAC
Starting torque	HST
Note	- / -

Applications with SC12CNX.2

	Conf. 1
Refrigerant	R290
Application	LBP+MBP
System cooling	fan 3m/s
Hot gas defrost	OK
Long interval pull down	OK

Electrical data - Configurations with SC12CNX.2

	Conf. 1
Starting device type	relay
Run capacitor	- / -
Start capacitor	240μF
LRA (locked rotor amps / 4s)	23,4A
RLA (rated load amps / 1s)	4,3A
Cut in current	23,4A

Model

Designation

SC12CNX.2

115V/60Hz 1~

Sales code:

104H7270

Compressor dimensions

Housing	A Height	209mm / 8,23in
	B Height	203mm / 7,99in
	C Length shell	218mm / 8,58in
	D Length w. cover	255mm / 10,04in
	E Width	151mm / 5,94in

Connectors	Suction X	Discharge Y	Process Z
Diameter [mm]	øi 9,54-9,72	øi 6,41-6,59	øi 6,41-6,59
(i:inside, o:outside) [in]	øi 0,38-0,38	øi 0,25-0,26	øi 0,25-0,26
Material	copper	copper	copper
Horizontal angle ±2°	37°	37°	143°
Vertical angle ±2°	30°	0°	150°
Position l/h/w [mm]	107/183/55	115/100/63	-107/183/55
[in]	4,2/7,2/2,2	4,5/3,9/2,5	-4,2/7,2/2,2
Straight tube l. [mm]	12	12	12
[in]	0,5	0,5	0,5

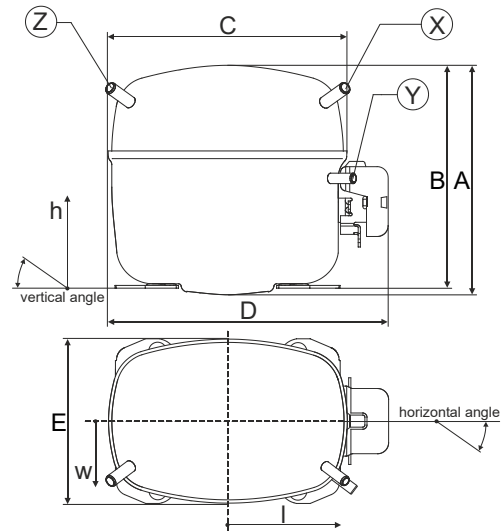

Compressor fixation

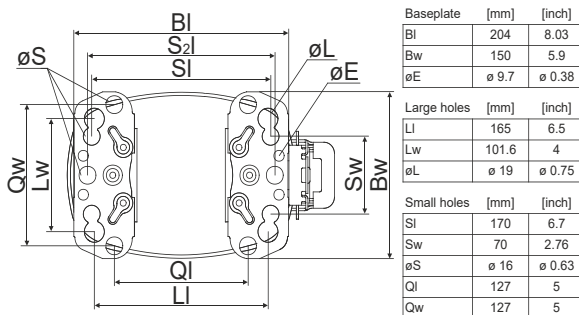

Bolt joint

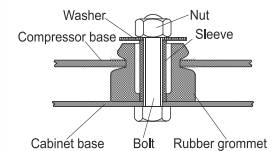

Snap-on

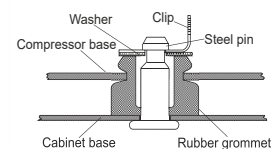

Mounting accessories

	one comp.	multi pack
Bolt joint M6 ø16mm	118-1917	118-1918
Bolt joint ø1/4" ø16mm	118-1946	
Bolt joint ø1/4" ø19mm	118-1949	
Snap-on ø7,3 ø16mm	118-1947	118-1919

Application notes

LRA value on compressor label and datasheet may differ due to different test conditions for UL approval.

Model

Designation	SC12CNX.2	115V/60Hz	Conf. 1	Sales code:	104H7270
-------------	------------------	------------------	----------------	-------------	-----------------

Configuration

Motorconfiguration	CSIR
Power supply (nominal)	115V/60Hz 1~
Refrigerant	R290
Application	LBP+MBP
Voltage range	95-135V
Starting torque	HST
Approvals	UL VDE EAC

Electrical accessories / wiring diagram

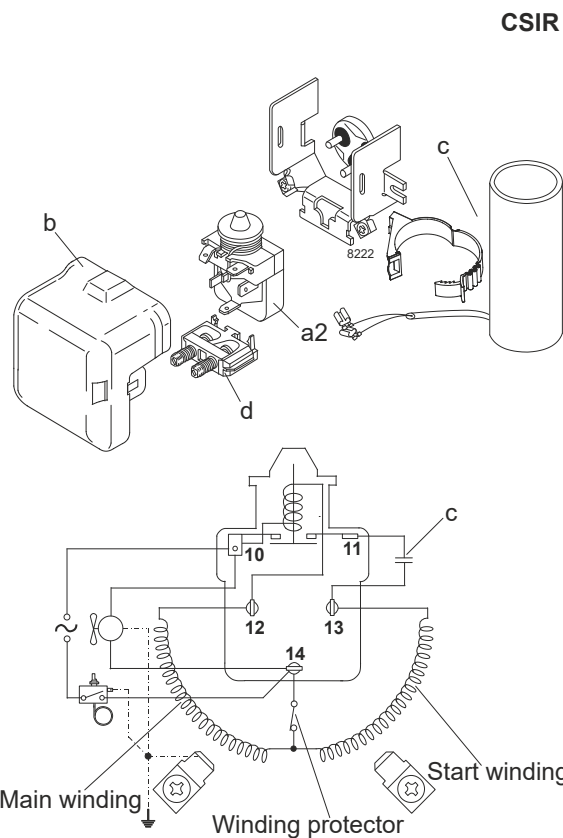

Ambient temperatures / system cooling

Ambient temperature min.:	10°C / 50°F
Ambient temperature max.:	43°C / 110°F

System cooling (n/a: outside limits)			
T ambient	LBP	MBP	HBP
32°C / 90°F	fan 3m/s	fan 3m/s	n/a
38°C / 100°F	fan 3m/s	fan 3m/s	n/a
43°C / 110°F	fan 3m/s	fan 3m/s	n/a

Operation pressure range

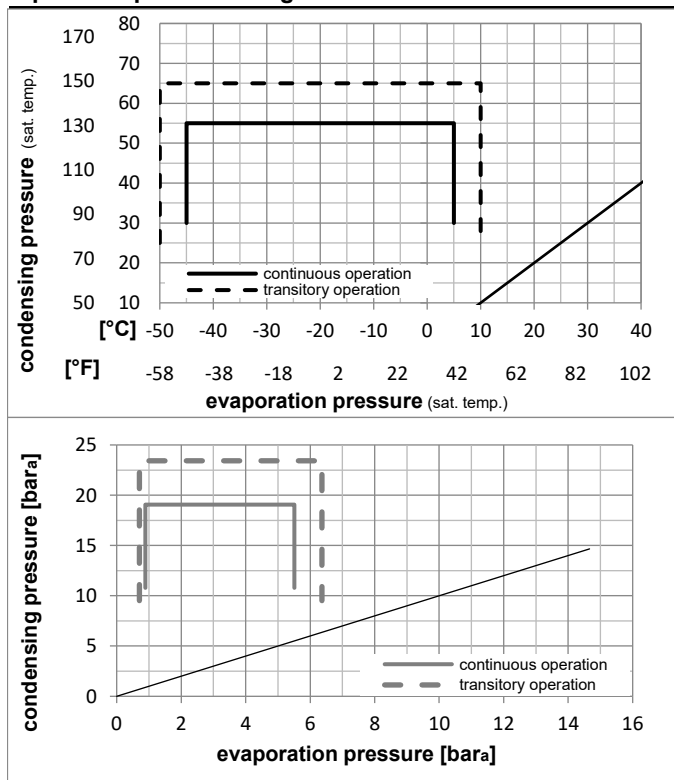

Components

a2	relay	117U7020
c	start capacitor (240µF)	117U5023
d	cord relief	103N1004
b	plastic cover	103N2008

Model

Designation	SC12CNX.2	115V/60Hz	Conf. 1	Sales code:	104H7270
-------------	------------------	------------------	----------------	-------------	-----------------

Optimization + standard conditions

R290, 115V/60Hz, CSIR, fan 3m/s, UL, VDE, EAC

	Evaporating pressure (saturation temperature)				Condensing pressure (saturation temperature)			Return gas temp.	Liquid temp.	Cooling capacity	COP	EER	Power consumption			ASHRAE LBP
	pe	pc	RGT	Tliq	[W]	[Btu/h]	[kcal/h]						P1	I	Ref. mass flow	
[°C]																
[°F]																
	-23	54	32	32	611,5	2088	526,3	1,29	4,40	1,11	475,1	6,11	6,19			
	-10	130	90	90												
	-25	55	32	55	449,4	1535	386,8	0,98	3,35	0,85	457,5	6,00	5,60			
	-13	131	90	131												
	-35	40	20	40	334,9	1144	288,3	0,97	3,30	0,83	346,5	5,42	3,83			
	-31	104	68	104												
	-7	54	35	46	1190,6	4066	1024,6	1,87	6,40	1,61	635,8	7,31	13,58			
	20	130	95	115												
	-10	55	32	55	935,7	3196	805,3	1,53	5,24	1,32	610,2	7,07	11,84			
	14	131	90	131												
	-10	45	20	45	1041,0	3555	895,9	1,88	6,43	1,62	553,0	6,74	12,78			
	14	113	68	113												

Performance tables

R290, 115V/60Hz, CSIR, fan 3m/s, UL, VDE, EAC

	pe		Cooling capacity			COP	EER	P1	I	m	
	[°C]	[°F]	[W]	[Btu/h]	[kcal/h]	[W/W]	[Btu/Wh]	[kcal/Wh]	[W]	[A]	[kg/h]
[°C / °F]	-45	-49	130,8	447	112,5	0,58	1,98	0,50	226,0	4,99	1,46
cond. pressure	-34	-30	319,6	1091	275,0	0,91	3,12	0,79	349,3	5,45	3,58
pc= 45/113	-29	-20	447,8	1529	385,4	1,11	3,79	0,95	403,8	5,72	5,04
return gas temp.	-23	-10	600,1	2050	516,5	1,33	4,53	1,14	452,6	6,00	6,78
RGT= 32/90	-15	5	881,0	3009	758,2	1,70	5,81	1,47	517,5	6,45	10,02
liquid temp	-4	25	1370,4	4680	1179,4	2,31	7,88	1,98	594,2	7,11	15,80
Tliq= 45/113	5	41	1872,2	6394	1611,3	2,87	9,79	2,47	653,0	7,68	21,90
[°C / °F]	-45	-49	60,2	206	51,8	0,34	1,17	0,30	175,1	4,75	0,74
cond. pressure	-34	-30	236,4	807	203,5	0,70	2,39	0,60	338,0	5,38	2,92
pc= 55/131	-29	-20	354,3	1210	304,9	0,86	2,94	0,74	410,9	5,74	4,40
return gas temp	-23	-10	493,7	1686	424,9	1,04	3,54	0,89	476,5	6,11	6,16
RGT= 32/90	-15	5	750,4	2563	645,8	1,33	4,55	1,15	563,3	6,70	9,43
liquid temp	-4	25	1198,3	4093	1031,3	1,81	6,17	1,55	663,6	7,54	15,29
Tliq= 55/131	5	41	1659,6	5668	1428,3	2,25	7,70	1,94	736,3	8,26	21,52