

## Model

Designation	<b>SC12GH</b>	<b>220-240V/50Hz 1~ 208-230V/60Hz 1~</b>	Sales code:	<b>104G8261</b>
-------------	---------------	--	-------------	-----------------

## Compressor design

Oil type	Polyolester	Refrigerant(s)	<b>R134a, R513A</b>
Oil viscosity	22cST	Displacement	12,87cm <sup>3</sup> / 0,79cu.in
Oil quantity	504cm <sup>3</sup> / 17fl.oz	Compressors on pallet	80
Refr. charge - tech. limit	1300g / 45,9oz		
Free gas volume comp.	1510cm <sup>3</sup> / 51,1fl.oz		
Weight	12,5kg / 27,6lbs		
Motor protection	1# internal		
Winding resistance main	4,4Ω (at 25°C)		
Winding resistance aux	14Ω (at 25°C)		
Max. winding temp.	125°C / 257°F		
Max. discharge temp.	130°C / 266°F		



## General - Configurations with SC12GH

	<b>Conf. 1</b>	<b>Conf. 2</b>	<b>Conf. 3</b>	<b>Conf. 4</b>
Motorconfiguration	CSIR	CSIR	CSIR	CSIR
Power supply (nominal)	220-240V/50Hz	220-240V/50Hz	208-230V/60Hz	208-230V/60Hz
Number of phases	1	1	1	1
Voltage range	198-254V	198-254V	198-254V	198-254V
Approvals	VDE, UL, KC	VDE, UL	VDE, UL, KC	VDE, UL
Starting torque	HST	HST	HST	HST
Note	- / -			

## Applications with SC12GH

	<b>Conf. 1</b>	<b>Conf. 2</b>	<b>Conf. 3</b>	<b>Conf. 4</b>
Refrigerant	R134a	R513A	R134a	R513A
Application	HBP	HBP	HBP	HBP
System cooling	fan 3m/s	fan 3m/s	fan 3m/s	fan 3m/s
Hot gas defrost	OK	OK	OK	OK
Long interval pull down	OK	OK	OK	OK

## Electrical data - Configurations with SC12GH

	<b>Conf. 1</b>	<b>Conf. 2</b>	<b>Conf. 3</b>	<b>Conf. 4</b>
Starting device type	relay	relay	relay	relay
Run capacitor	-/-	-/-	-/-	-/-
Start capacitor	80μF	80μF	80μF	80μF
LRA (locked rotor amps / 4s)	19A	19A	18,3A	18,3A
RLA (rated load amps / 1s)	3,9A	3,9A	3,52A	3,52A
Cut in current	19A	19A	18,3A	18,3A

## Model

Designation **SC12GH** 220-240V/50Hz 1~ 208-230V/60Hz 1~ Sales code: **104G8261**

## Compressor dimensions

<b>Housing</b>	A Height	209mm / 8,23in
	B Height	203mm / 7,99in
	C Length shell	218mm / 8,58in
	D Length w. cover	255mm / 10,04in
	E Width	151mm / 5,94in

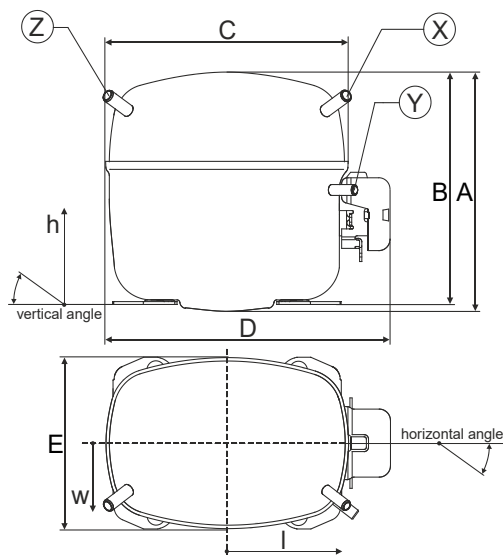

Connectors	Suction		Discharge		Process	
	X		Y		Z	
Diameter [mm]	øi 10,11-10,29		øi 8,11-8,29		øi 6,11-6,29	
(i:inside, o:outside) [in]	øi 0,4-0,41		øi 0,32-0,33		øi 0,24-0,25	
Material	copper		copper		copper	
Horizontal angle ±2°	37°		37°		143°	
Vertical angle ±2°	30°		0°		150°	
Position l/h/w [mm]	107/183/55		115/100/63		-107/183/55	
[in]	4,2/7,2/2,2		4,5/3,9/2,5		-4,2/7,2/2,2	
Straight tube l. [mm]	12		12		12	
[in]	0,5		0,5		0,5	

## Compressor fixation

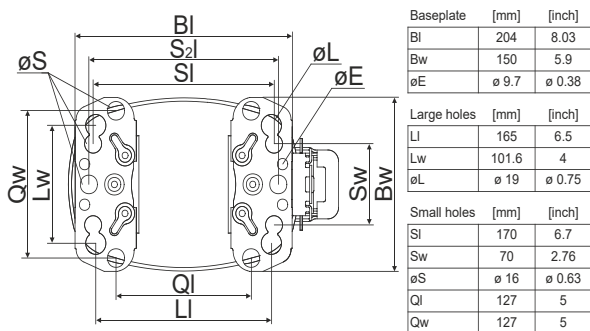

### Bolt joint

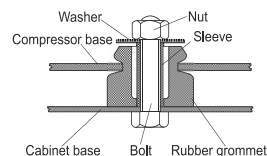

### Snap-on

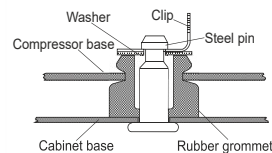

Mounting accessories	one comp.	multi pack
Bolt joint   M6   ø16mm	118-1917	118-1918
Bolt joint   ø1/4"   ø16mm	118-1946	
Bolt joint   ø1/4"   ø19mm	118-1949	
Snap-on   ø7,3   ø16mm	118-1947	118-1919

## Application notes

Provision for PE Grounding is located at the PE Stamp on the compressor

## Model

Designation	<b>SC12GH</b>	<b>220-240V/50Hz</b>	Conf. 1	Sales code:	<b>104G8261</b>
-------------	---------------	----------------------	---------	-------------	-----------------

## Configuration

Motorconfiguration	CSIR
Power supply (nominal)	220-240V/50Hz 1~
Refrigerant	R134a
Application	HBP
Voltage range	198-254V
Starting torque	HST
Approvals	VDE
	UL
	KC

## Electrical accessories / wiring diagram

CSIR

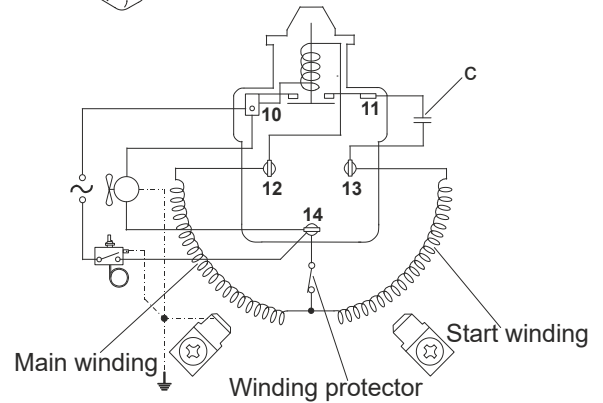
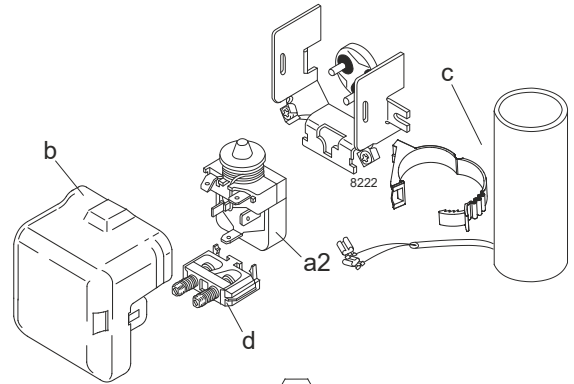

## Ambient/ machine room temperatures minimum /maximum

Ambient temperature range: 10 - 43°C / 50 - 110°F

Machine room temperature range: 10 - 48°C / 50 - 119°F

Compressor cooling: fan 3m/s

## Operation Limits

## Operation pressure range

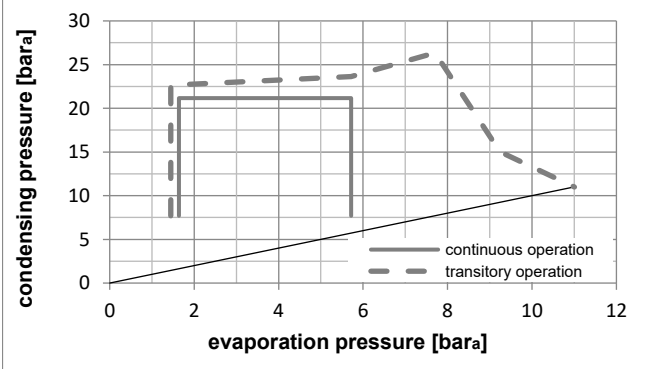
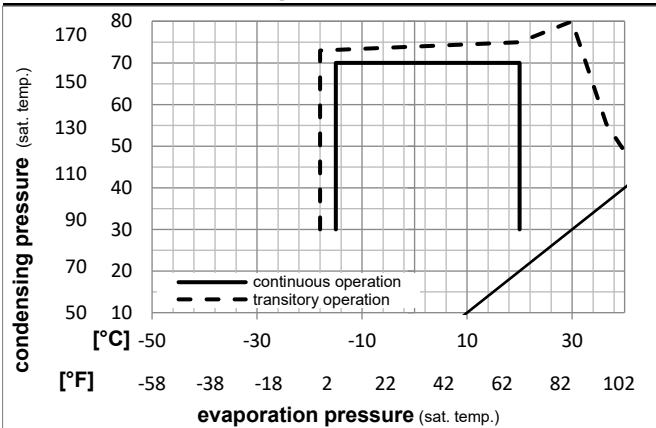

## Components

a2	relay	117U6011
c	start capacitor (80μF)	117U5017
d	cord relief	103N1004
b	plastic cover	103N2008

## Model

Designation **SC12GH** **220-240V/50Hz** Conf. 1 Sales code: **104G8261**

## Optimization + standard conditions

R134a, 220V/50Hz, CSIR, fan 3m/s, VDE, UL, KC

Evaporating pressure (saturation temperature)				Condensing pressure (saturation temperature)			Return gas temp.			Liquid temp.			Cooling capacity			COP	EER	Power consumption		
pe	pc	RGT	Tliq	[W]	[Btu/h]	[kcal/h]	[W/W]	[Btu/Wh]	[kcal/Wh]	P1	I	Ref. mass flow								
[°C]	[°C]	[°C]	[°C]	[W]	[Btu/h]	[kcal/h]	[W/W]	[Btu/Wh]	[kcal/Wh]	[W]	[A]	[kg/h]								
7,2	54	35	46	1175,9	4016	1012,0	2,34	8,00	2,02	501,9	3,52	26,09	ASHRAE HBP							
[°F]	[°F]	[°F]	[°F]																	
45	130	95	115																	
5	55	32	55	957,3	3269	823,9	1,97	6,71	1,69	487,1	3,47	23,59	cecomaf HBP							
[°C]	[°C]	[°C]	[°C]																	
[°F]	[°F]	[°F]	[°F]																	
41	131	90	131																	
5	50	20	50	998,2	3409	859,0	2,15	7,34	1,85	464,7	3,39	25,15	EN12900 HBP							
[°C]	[°C]	[°C]	[°C]																	
[°F]	[°F]	[°F]	[°F]																	
41	122	68	122																	
-7	54	35	46	583,7	1994	502,4	1,52	5,18	1,30	385,2	3,16	12,74	ASHRAE MBP							
[°C]	[°C]	[°C]	[°C]																	
[°F]	[°F]	[°F]	[°F]																	
20	130	95	115																	
-10	55	32	55	428,7	1464	368,9	1,20	4,11	1,04	356,3	3,08	10,37	cecomaf MBP							
[°C]	[°C]	[°C]	[°C]																	
[°F]	[°F]	[°F]	[°F]																	
14	131	90	131																	
-10	45	20	45	517,8	1768	445,7	1,49	5,08	1,28	348,4	3,06	12,12	EN12900 MBP							
[°C]	[°C]	[°C]	[°C]																	
[°F]	[°F]	[°F]	[°F]																	
14	113	68	113																	

## Performance tables

R134a, 220V/50Hz, CSIR, fan 3m/s, VDE, UL, KC

	pe	Cooling capacity			COP	EER	P1	I	m		
	[°C]	[°F]	[W]	[Btu/h]	[kcal/h]	[W/W]	[Btu/Wh]	[kcal/Wh]	[W]	[A]	[kg/h]
[°C / °F]	-15	5	395,5	1351	340,3	1,27	4,33	1,09	312,2	2,98	8,62
cond. pressure	-10	14	537,2	1835	462,4	1,54	5,27	1,33	348,4	3,06	11,76
pc= 45/113	-5	23	704,5	2406	606,3	1,84	6,28	1,58	383,3	3,14	15,49
return gas temp.	0	32	901,0	3077	775,4	2,17	7,40	1,87	415,7	3,23	19,92
RGT= 32/90	5	41	1130,2	3860	972,7	2,54	8,69	2,19	444,3	3,31	25,16
liquid temp	15	59	1701,6	5811	1464,4	3,51	11,98	3,02	485,3	3,47	38,54
Tliq= 45/113	20	68	2051,1	7005	1765,2	4,14	14,14	3,56	495,3	3,55	46,98
[°C / °F]	-15	5	302,4	1033	260,3	0,97	3,31	0,83	312,0	2,94	7,28
cond. pressure	-10	14	428,7	1464	368,9	1,20	4,11	1,04	356,3	3,08	10,37
pc= 55/131	-5	23	577,5	1972	497,0	1,44	4,92	1,24	401,0	3,21	14,04
return gas temp	0	32	752,5	2570	647,6	1,69	5,77	1,46	445,0	3,34	18,41
RGT= 32/90	5	41	957,3	3269	823,9	1,97	6,71	1,69	487,1	3,47	23,59
liquid temp	15	59	1471,0	5024	1265,9	2,62	8,96	2,26	560,6	3,73	36,95
Tliq= 55/131	20	68	1787,1	6103	1538,0	3,03	10,35	2,61	589,6	3,86	45,44

## Model

Designation	<b>SC12GH</b>	<b>220-240V/50Hz</b>	Conf. 2	Sales code:	<b>104G8261</b>
-------------	---------------	----------------------	---------	-------------	-----------------

## Configuration

Motorconfiguration	CSIR
Power supply (nominal)	220-240V/50Hz 1~
Refrigerant	R513A
Application	HBP
Voltage range	198-254V
Starting torque	HST
Approvals	VDE UL

## Electrical accessories / wiring diagram

CSIR

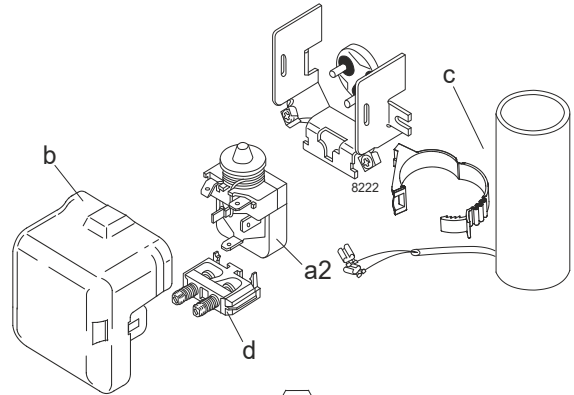

## Ambient/ machine room temperatures minimum /maximum

Ambient temperature range: 10 - 43°C / 50 - 110°F

Machine room temperature range: 10 - 48°C / 50 - 119°F

Compressor cooling: fan 3m/s

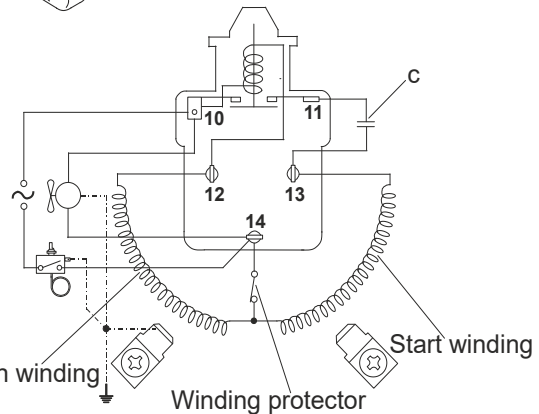

## Operation Limits

### Operation pressure range

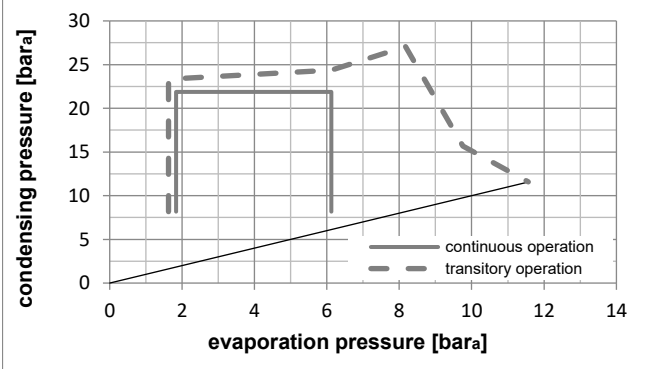
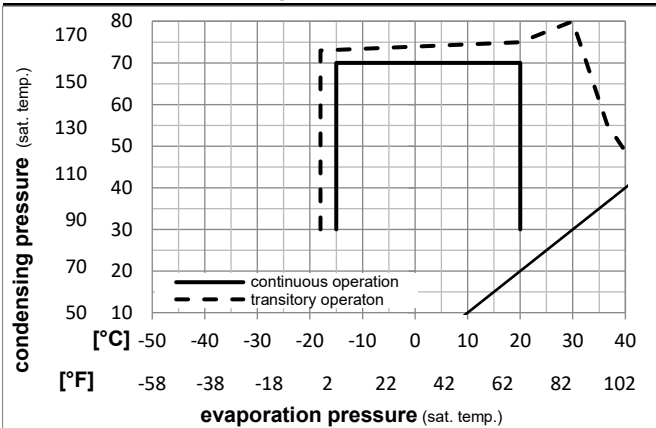

### Components

a2	relay	117U6011
c	start capacitor (80µF)	117U5017
d	cord relief	103N1004
b	plastic cover	103N2008

## Model

Designation	<b>SC12GH</b>	<b>220-240V/50Hz</b>	<b>Conf. 2</b>	Sales code:	<b>104G8261</b>
-------------	---------------	----------------------	----------------	-------------	-----------------

## Optimization + standard conditions

R513A, 220V/50Hz, CSIR, fan 3m/s, VDE, UL

		Evaporating pressure (saturation temperature)				Cooling capacity					COP			EER			Power consumption		Ref. mass flow ṁ [kg/h]	
		Condensing pressure (saturation temperature)		Return gas temp.		Liquid temp.		Cooling capacity		COP		EER		P1		Current consumption				
pe	pc	RGT	Tliq	[W]	[Btu/h]	[kcal/h]	[W/W]	[Btu/Wh]	[kcal/Wh]	[W]	[A]	[kg/h]								
[°C]	7,2	54	35	46	1210,2	4133	1041,5	2,31	7,90	1,99	522,9	3,59	30,06	<b>ASHRAE HBP</b>						
[°F]	45	130	95	115																
[°C]	5	55	32	55	970,8	3316	835,5	1,91	6,52	1,64	508,5	3,54	27,28	<b>cecomaf HBP</b>						
[°F]	41	131	90	131																
[°C]	5	50	20	50	1013,9	3463	872,6	2,09	7,14	1,80	484,8	3,47	29,07	<b>EN12900 HBP</b>						
[°F]	41	122	68	122																
[°C]	-7	54	35	46	613,9	2097	528,4	1,51	5,16	1,30	406,7	3,23	15,04	<b>ASHRAE MBP</b>						
[°F]	20	130	95	115																
[°C]	-10	55	32	55	445,8	1523	383,7	1,18	4,03	1,02	377,6	3,14	12,33	<b>cecomaf MBP</b>						
[°F]	14	131	90	131																
[°C]	-10	45	20	45	542,1	1852	466,6	1,47	5,03	1,27	368,3	3,11	14,37	<b>EN12900 MBP</b>						
[°F]	14	113	68	113																

## Performance tables

R513A, 220V/50Hz, CSIR, fan 3m/s, VDE, UL

	pe		Cooling capacity			COP		EER		P1	I	m
	[°C]	[°F]	[W]	[Btu/h]	[kcal/h]	[W/W]	[Btu/Wh]	[kcal/Wh]	[W]	[A]	[kg/h]	
[°C / °F]	-15	5	421,5	1440	362,8	1,27	4,34	1,09	331,5	2,99	10,33	
cond. pressure	-10	14	566,9	1936	487,9	1,54	5,26	1,32	368,3	3,11	13,94	
pc= 45/113	-5	23	737,1	2517	634,3	1,83	6,24	1,57	403,3	3,22	18,19	
return gas temp.	0	32	935,4	3195	805,0	2,15	7,34	1,85	435,4	3,31	23,20	
RGT= 32/90	5	41	1165,5	3980	1003,0	2,52	8,59	2,16	463,3	3,40	29,07	
liquid temp	15	59	1734,6	5924	1492,8	3,45	11,80	2,97	502,2	3,52	43,89	
Tliq= 45/113	20	68	2080,5	7105	1790,5	4,07	13,91	3,50	510,9	3,55	53,12	
[°C / °F]	-15	5	318,2	1087	273,8	0,96	3,27	0,82	332,4	3,00	8,76	
cond. pressure	-10	14	445,8	1523	383,7	1,18	4,03	1,02	377,6	3,14	12,33	
pc= 55/131	-5	23	594,8	2031	511,9	1,41	4,81	1,21	422,7	3,28	16,52	
return gas temp	0	32	768,7	2625	661,5	1,65	5,62	1,42	466,8	3,41	21,47	
RGT= 32/90	5	41	970,8	3316	835,5	1,91	6,52	1,64	508,5	3,54	27,28	
liquid temp	15	59	1473,9	5034	1268,5	2,54	8,67	2,19	580,5	3,76	42,09	
Tliq= 55/131	20	68	1781,8	6085	1533,4	2,93	10,00	2,52	608,5	3,85	51,41	

### Model

Designation	<b>SC12GH</b>	<b>208-230V/60Hz</b>	<b>Conf. 3</b>	Sales code:	<b>104G8261</b>
-------------	---------------	----------------------	----------------	-------------	-----------------

### Configuration

Motorconfiguration	CSIR
Power supply (nominal)	208-230V/60Hz 1~
Refrigerant	R134a
Application	HBP
Voltage range	198-254V
Starting torque	HST
Approvals	VDE
	UL
	KC

### Electrical accessories / wiring diagram

CSIR

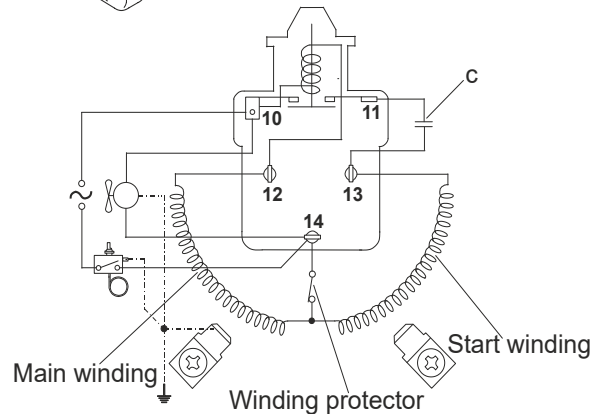
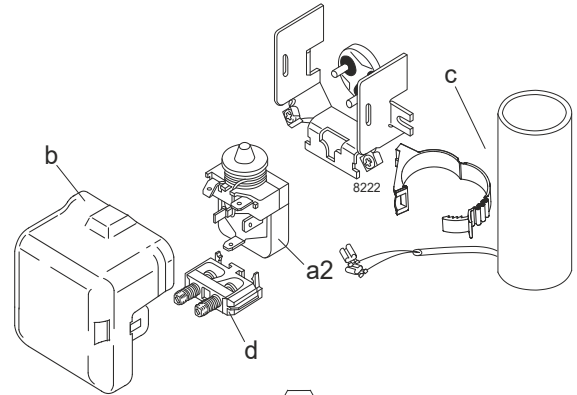

### Ambient/ machine room temperatures minimum /maximum

Ambient temperature range: 10 - 43°C / 50 - 110°F

Machine room temperature range: 10 - 48°C / 50 - 119°F

Compressor cooling: fan 3m/s

### Operation Limits

### Operation pressure range

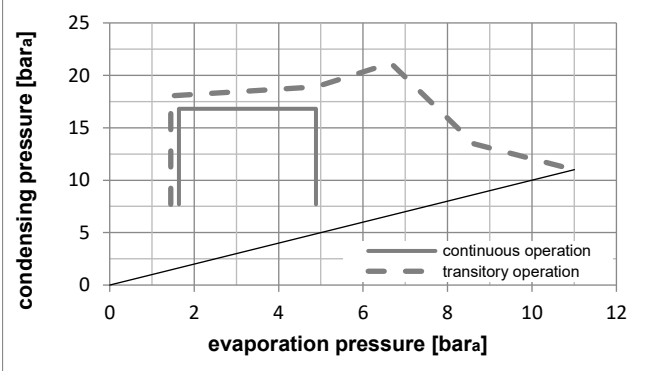
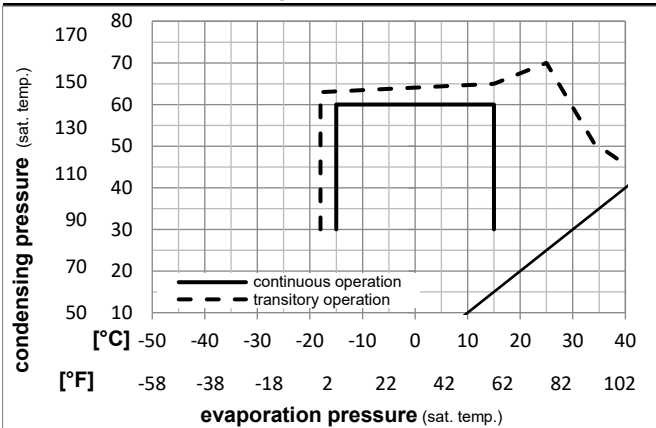

### Components

a2	relay	117U6011
c	start capacitor (80µF)	117U5017
d	cord relief	103N1004
b	plastic cover	103N2008

## Model

Designation	<b>SC12GH</b>	<b>208-230V/60Hz</b>	<b>Conf. 3</b>	Sales code:	<b>104G8261</b>
-------------	---------------	----------------------	----------------	-------------	-----------------

## Optimization + standard conditions

R134a, 230V/60Hz, CSIR, fan 3m/s, VDE, UL, KC

		Evaporating pressure (saturation temperature)				Condensing pressure (saturation temperature)						Power consumption			
		Return gas temp.		Liquid temp.		Cooling capacity		COP	EER		P1	I	Ref. mass flow		
		pe	pc	RGT	Tliq	[W]	[Btu/h]	[kcal/h]	[W/W]	[Btu/Wh]	[kcal/Wh]	[W]	[A]	[kg/h]	
[°C]	7,2	54	35	46	1370,3	4680	1179,3	2,38	8,13	2,05	575,7	3,36	30,40	<b>ASHRAE HBP</b>	
[°F]	45	130	95	115											
[°C]	5	55	32	55	1116,4	3813	960,8	2,01	6,86	1,73	555,8	3,28	27,51	<b>cecomaf HBP</b>	
[°F]	41	131	90	131											
[°C]	5	50	20	50	1163,6	3974	1001,4	2,20	7,53	1,90	528,0	3,16	29,32	<b>EN12900 HBP</b>	
[°F]	41	122	68	122											
[°C]	-7	54	35	46	688,4	2351	592,4	1,62	5,53	1,39	425,5	2,76	15,02	<b>ASHRAE MBP</b>	
[°F]	20	130	95	115											
[°C]	-10	55	32	55	511,2	1746	440,0	1,31	4,49	1,13	388,9	2,61	12,36	<b>cecomaf MBP</b>	
[°F]	14	131	90	131											
[°C]	-10	45	20	45	608,8	2079	523,9	1,61	5,49	1,38	378,9	2,57	14,25	<b>EN12900 MBP</b>	
[°F]	14	113	68	113											

## Performance tables

R134a, 230V/60Hz, CSIR, fan 3m/s, VDE, UL, KC

	pe		Cooling capacity			COP	EER		P1	I	m
	[°C]	[°F]	[W]	[Btu/h]	[kcal/h]	[W/W]	[Btu/Wh]	[kcal/Wh]	[W]	[A]	[kg/h]
[°C / °F]	-15	5	469,7	1604	404,2	1,41	4,80	1,21	334,0	2,39	10,24
cond. pressure	-10	14	631,6	2157	543,5	1,67	5,69	1,43	378,9	2,57	13,82
pc= 45/113	-5	23	824,5	2816	709,6	1,95	6,67	1,68	422,3	2,74	18,13
return gas temp.	0	32	1052,5	3594	905,8	2,27	7,75	1,95	463,8	2,90	23,28
RGT= 32/90	5	41	1319,7	4507	1135,7	2,62	8,96	2,26	502,8	3,05	29,38
liquid temp	10	50	1630,1	5567	1402,9	3,03	10,34	2,60	538,6	3,19	36,58
Tliq= 45/113	15	59	1987,8	6789	1710,7	3,48	11,90	3,00	570,6	3,33	45,03
[°C / °F]	-15	5	371,0	1267	319,3	1,12	3,81	0,96	332,3	2,37	8,93
cond. pressure	-10	14	511,2	1746	440,0	1,31	4,49	1,13	388,9	2,61	12,36
pc= 55/131	-5	23	679,5	2321	584,8	1,53	5,21	1,31	445,5	2,84	16,52
return gas temp	0	32	879,9	3005	757,2	1,76	5,99	1,51	501,3	3,06	21,52
RGT= 32/90	5	41	1116,4	3813	960,8	2,01	6,86	1,73	555,8	3,28	27,51
liquid temp	10	50	1393,1	4758	1199,0	2,29	7,82	1,97	608,3	3,49	34,63
Tliq= 55/131	15	59	1714,2	5854	1475,3	2,60	8,89	2,24	658,4	3,68	43,06



## Model

Designation	<b>SC12GH</b>	<b>208-230V/60Hz</b>	Conf. 4	Sales code:	<b>104G8261</b>
-------------	---------------	----------------------	---------	-------------	-----------------

## Configuration

Motorconfiguration	CSIR
Power supply (nominal)	208-230V/60Hz 1~
Refrigerant	R513A
Application	HBP
Voltage range	198-254V
Starting torque	HST
Approvals	VDE UL

## Electrical accessories / wiring diagram

CSIR

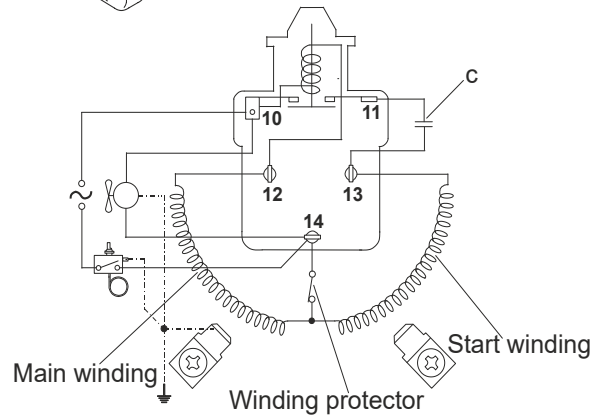
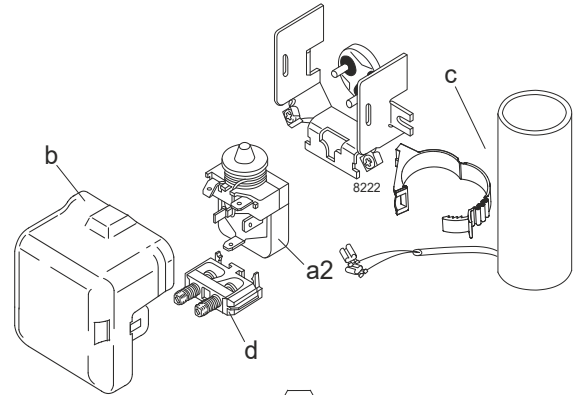

## Ambient/ machine room temperatures minimum /maximum

Ambient temperature range: 10 - 43°C / 50 - 110°F

Machine room temperature range: 10 - 48°C / 50 - 119°F

Compressor cooling: fan 3m/s

## Operation Limits

### Operation pressure range

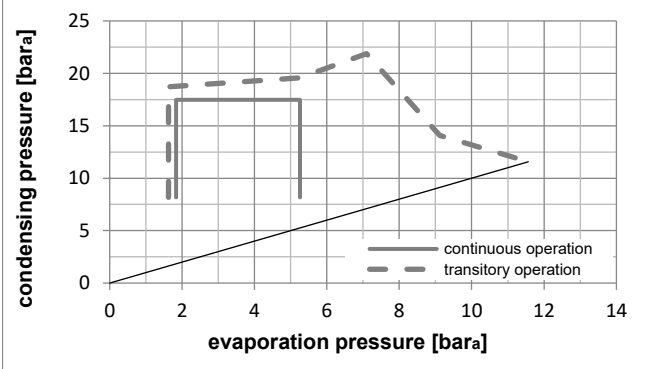
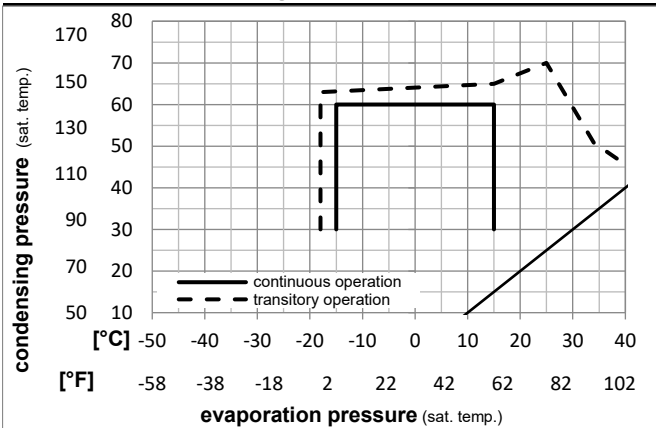

### Components

a2	relay	117U6011
c	start capacitor (80µF)	117U5017
d	cord relief	103N1004
b	plastic cover	103N2008

## Model

Designation	<b>SC12GH</b>	<b>208-230V/60Hz</b>	Conf. 4	Sales code:	<b>104G8261</b>
-------------	---------------	----------------------	---------	-------------	-----------------

## Optimization + standard conditions

R513A, 230V/60Hz, CSIR, fan 3m/s, VDE, UL

		Evaporating pressure (saturation temperature)				Condensing pressure (saturation temperature)						Power consumption			
		Return gas temp.				Liquid temp.						Current consumption			Ref. mass flow
		Cooling capacity				COP		EER		P1	I	m			
		pe	pc	RGT	Tliq	[W]	[Btu/h]	[kcal/h]	[W/W]	[Btu/Wh]	[kcal/Wh]	[W]	[A]	[kg/h]	
[°C]	[°F]														
		7,2	54	35	46	1410,5	4817	1213,9	2,35	8,03	2,02	600,1	3,45	35,04	<b>ASHRAE HBP</b>
		45	130	95	115										
		5	55	32	55	1132,3	3867	974,4	1,95	6,66	1,68	580,5	3,37	31,82	<b>cecomaf HBP</b>
		41	131	90	131										
		5	50	20	50	1182,1	4037	1017,4	2,14	7,32	1,85	551,3	3,25	33,90	<b>EN12900 HBP</b>
		41	122	68	122										
		-7	54	35	46	724,1	2473	623,2	1,61	5,50	1,39	449,8	2,85	17,74	<b>ASHRAE MBP</b>
		20	130	95	115										
		-10	55	32	55	531,8	1816	457,7	1,29	4,40	1,11	412,8	2,70	14,70	<b>cecomaf MBP</b>
		14	131	90	131										
		-10	45	20	45	637,4	2177	548,6	1,59	5,43	1,37	401,1	2,65	16,89	<b>EN12900 MBP</b>
		14	113	68	113										

## Performance tables

R513A, 230V/60Hz, CSIR, fan 3m/s, VDE, UL

	pe		Cooling capacity			COP		EER		P1	I	m
	[°C]	[°F]	[W]	[Btu/h]	[kcal/h]	[W/W]	[Btu/Wh]	[kcal/Wh]	[W]	[A]	[kg/h]	
[°C / °F]	-15	5	500,7	1710	430,9	1,41	4,81	1,21	355,4	2,47	12,27	
cond. pressure	-10	14	666,6	2276	573,6	1,66	5,68	1,43	401,1	2,65	16,39	
pc= 45/113	-5	23	862,7	2946	742,4	1,94	6,62	1,67	444,9	2,83	21,30	
return gas temp.	0	32	1092,8	3732	940,5	2,25	7,68	1,93	486,3	2,99	27,11	
RGT= 32/90	5	41	1361,0	4648	1171,3	2,59	8,86	2,23	524,7	3,15	33,95	
liquid temp	10	50	1670,9	5706	1438,0	2,98	10,19	2,57	559,8	3,29	41,95	
Tliq= 45/113	15	59	2026,4	6921	1744,0	3,43	11,71	2,95	591,0	3,41	51,27	
[°C / °F]	-15	5	390,4	1333	335,9	1,10	3,76	0,95	354,8	2,47	10,75	
cond. pressure	-10	14	531,8	1816	457,7	1,29	4,40	1,11	412,8	2,70	14,70	
pc= 55/131	-5	23	700,0	2391	602,5	1,49	5,09	1,28	470,1	2,93	19,44	
return gas temp	0	32	898,9	3070	773,6	1,71	5,83	1,47	526,2	3,15	25,10	
RGT= 32/90	5	41	1132,3	3867	974,4	1,95	6,66	1,68	580,5	3,37	31,82	
liquid temp	10	50	1404,0	4795	1208,3	2,22	7,58	1,91	632,6	3,58	39,75	
Tliq= 55/131	15	59	1717,8	5867	1478,4	2,52	8,60	2,17	682,0	3,78	49,06	