

Model

Designation	SC15DL	220-240V/50Hz 1~	Sales code:	104L2866
-------------	---------------	------------------	-------------	-----------------

Compressor design

Oil type	Polyolester	Refrigerant(s)	R404A, R507, R407C
Oil viscosity	32cST	Displacement	15,28cm ³ / 0,93cu.in
Oil quantity	550cm ³ / 18,6fl.oz	Compressors on pallet	80
Refr. charge - tech. limit	1300g / 45,9oz		
Free gas volume comp.	1460cm ³ / 49,4fl.oz		
Weight	13,5kg / 29,8lbs		
Motor protection	1# internal		
Winding resistance main	3,5Ω (at 25°C)		
Winding resistance aux	13Ω (at 25°C)		
Max. winding temp.	125°C / 257°F		
Max. discharge temp.	130°C / 266°F		



General - Configurations with SC15DL

	Conf. 1	Conf. 2
Motorconfiguration	CSCR	CSCR
Power supply (nominal)	220-240V/50Hz	220-240V/50Hz
Number of phases	1	1
Voltage range	198-254V	198-254V
Approvals	VDE, CCC	VDE, CCC
Starting torque	HST	HST
Note	- / -	

Applications with SC15DL

	Conf. 1	Conf. 2
Refrigerant	R404A	R407C
Application	HBP	HBP
System cooling	fan 3m/s	fan 3m/s
Hot gas defrost	OK	OK
Long interval pull down	OK	OK

Electrical data - Configurations with SC15DL

	Conf. 1	Conf. 2
Starting device type	relay	relay
Run capacitor	10μF	10μF
Start capacitor	80μF	80μF
LRA (locked rotor amps / 4s)	22A	22A
RLA (rated load amps / 1s)	3,9A	3,9A
Cut in current	22A	22A

Model

Designation

SC15DL

220-240V/50Hz 1~

Sales code:

104L2866

Compressor dimensions

Housing	A Height	219mm / 8,62in
	B Height	213mm / 8,39in
	C Length shell	218mm / 8,58in
	D Length w. cover	255mm / 10,04in
	E Width	151mm / 5,94in

Connectors		Suction	Discharge	Process
		X	Y	Z
Diameter	[mm]	øi 10,11-10,29	øi 6,11-6,29	øi 6,11-6,29
	(i:inside, o:outside) [in]	øi 0,4-0,41	øi 0,24-0,25	øi 0,24-0,25
Material		copper	copper	copper
Horizontal angle	±2°	37°	37°	143°
Vertical angle	±2°	30°	0°	150°
Position l/h/w	[mm]	107/193/55	115/110/63	-107/193/55
	[in]	4,2/7,6/2,2	4,5/4,3/2,5	-4,2/7,6/2,2
Straight tube l.	[mm]	12	12	12
	[in]	0,5	0,5	0,5

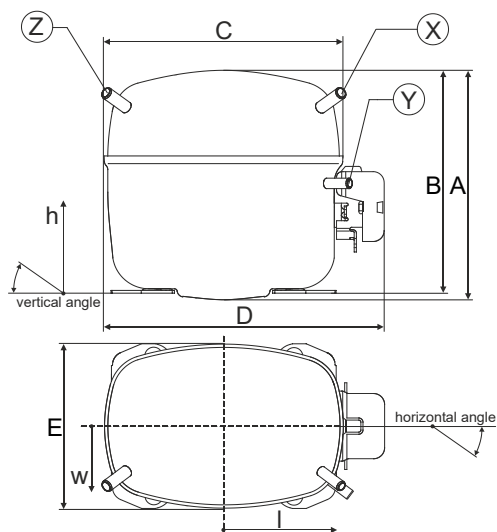

Compressor fixation



Bolt joint



Snap-on

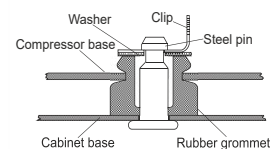

Mounting accessories

	one comp.	multi pack
Bolt joint M6 ø16mm	118-1917	118-1918
Bolt joint ø1/4" ø16mm	118-1946	
Bolt joint ø1/4" ø19mm	118-1949	
Snap-on ø7,3 ø16mm	118-1947	118-1919

Application notes

Provision for PE Grounding is located at the PE Stamp on the compressor

Model

Designation	SC15DL	220-240V/50Hz	Conf. 1	Sales code:	104L2866
-------------	---------------	----------------------	----------------	-------------	-----------------

Configuration

Motorconfiguration	CSCR
Power supply (nominal)	220-240V/50Hz 1~
Refrigerant	R404A
Application	HBP
Voltage range	198-254V
Starting torque	HST
Approvals	VDE CCC

Electrical accessories / wiring diagram

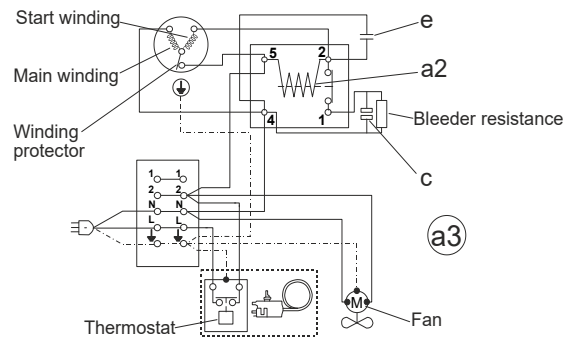
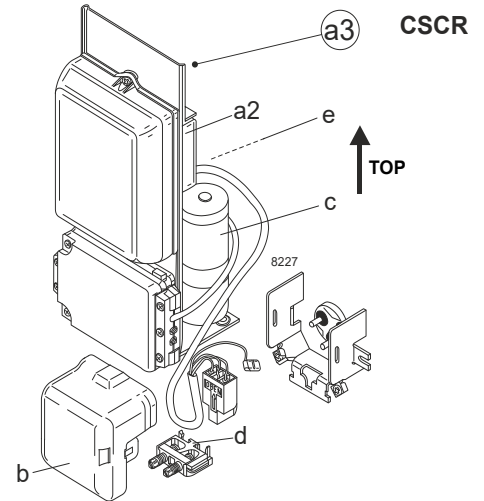

Ambient/ machine room temperatures minimum /maximum

Ambient temperature range:	10 - 38°C / 50 - 101°F
Machine room temperature range:	10 - 43°C / 50 - 110°F
Compressor cooling:	fan 3m/s

Operation Limits

Operation pressure range

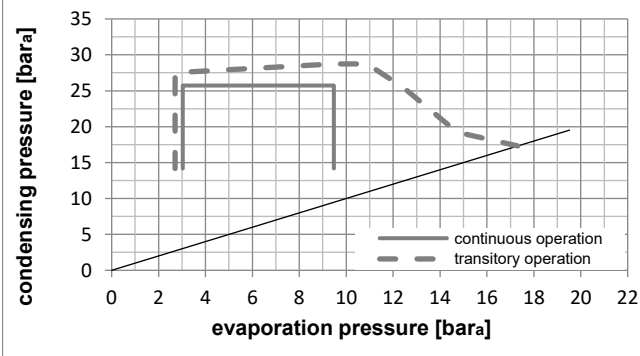
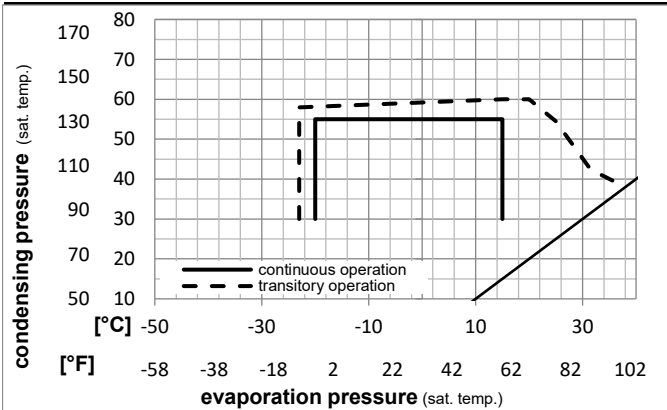

Components

a3	SC starter kit (550mm)	117-7029
b	plastic cover	103N2009
d	cord relief	103N1004

Alternative components

a3	SC starter kit (650mm)	117-7032
a3	SC starter kit (1000mm)	117-7041
a2	potential relay (RVA 4H3R341)	117-7427
c	start capacitor (80µF)	117U5373
e	run capacitor (10µF, 6.3mm)	117-7112

Model

Designation **SC15DL** **220-240V/50Hz** Conf. 1 Sales code: **104L2866**

Optimization + standard conditions

R404A, 220V/50Hz, CSCR, fan 3m/s, VDE, CCC

		Evaporating pressure (saturation temperature)				Condensing pressure (saturation temperature)			Return gas temp.			Liquid temp.			Cooling capacity			COP			EER			Power consumption			Current consumption			Ref. mass flow					
		pe	pc	RGT	Tliq	[W]	[Btu/h]	[kcal/h]	[W/W]	[Btu/Wh]	[kcal/Wh]	P1	I	m	[W]	[A]	[kg/h]																		
[°C]	[°F]																	ASHRAE HBP			cecomaf HBP			EN12900 HBP			ASHRAE MBP			cecomaf MBP			EN12900 MBP		
7,2	45	54	35	46	2265,3	7737	1949,6	2,25	7,67	1,93	1008,0	5,16	64,41																						
5	41	55	32	55	1777,2	6069	1529,4	1,79	6,10	1,54	994,3	5,09	59,18																						
5	41	50	20	50	1847,7	6310	1590,1	2,00	6,82	1,72	924,6	4,77	63,01																						
-7	20	54	35	46	1312,8	4484	1129,8	1,56	5,33	1,34	840,7	4,34	36,12																						
-10	14	55	32	55	969,9	3312	834,7	1,22	4,17	1,05	794,9	4,12	31,05																						
-10	14	45	20	45	1137,5	3885	978,9	1,58	5,38	1,36	722,1	3,79	34,26																						

Performance tables

R404A, 220V/50Hz, CSCR, fan 3m/s, VDE, CCC

	pe		Cooling capacity			COP			EER			P1			I			m			
	[°C]	[°F]	[W]	[Btu/h]	[kcal/h]	[W/W]	[Btu/Wh]	[kcal/Wh]	[W]	[A]	[kg/h]	[W]	[A]	[kg/h]	[W]	[A]	[kg/h]	[W]	[A]	[kg/h]	
[°C / °F]	-20	-4	758,8	2591	653,0	1,29	4,40	1,11	588,8	3,09	20,59										
cond. pressure	-15	5	964,2	3293	829,8	1,46	5,00	1,26	659,1	3,46	26,34										
pc= 45/113	-10	14	1207,2	4123	1038,9	1,67	5,71	1,44	722,1	3,79	33,24										
return gas temp.	-5	23	1492,6	5098	1284,6	1,92	6,56	1,65	777,6	4,07	41,50										
RGT= 32/90	0	32	1825,3	6234	1570,9	2,21	7,55	1,90	825,2	4,31	51,32										
liquid temp	5	41	2210,2	7548	1902,1	2,56	8,73	2,20	864,7	4,50	62,96										
Tliq= 45/113	15	59	3155,6	10777	2715,8	3,44	11,74	2,96	918,3	4,75	93,05										
[°C / °F]	-20	-4	576,5	1969	496,1	0,93	3,18	0,80	618,6	3,25	18,14										
cond. pressure	-15	5	761,9	2602	655,7	1,07	3,66	0,92	710,9	3,71	24,16										
pc= 55/131	-10	14	969,9	3312	834,7	1,22	4,17	1,05	794,9	4,12	31,05										
return gas temp	-5	23	1205,2	4116	1037,2	1,38	4,73	1,19	870,4	4,49	39,01										
RGT= 32/90	0	32	1472,6	5029	1267,4	1,57	5,37	1,35	936,9	4,81	48,29										
liquid temp	5	41	1777,2	6069	1529,4	1,79	6,10	1,54	994,3	5,09	59,18										
Tliq= 55/131	15	59	2516,7	8595	2165,9	2,33	7,95	2,00	1080,6	5,52	87,28										

Model

Designation	SC15DL	220-240V/50Hz	Conf. 2	Sales code:	104L2866
-------------	---------------	----------------------	----------------	-------------	-----------------

Configuration

Motorconfiguration	CSCR
Power supply (nominal)	220-240V/50Hz 1~
Refrigerant	R407C
Application	HBP
Voltage range	198-254V
Starting torque	HST
Approvals	VDE CCC

Electrical accessories / wiring diagram

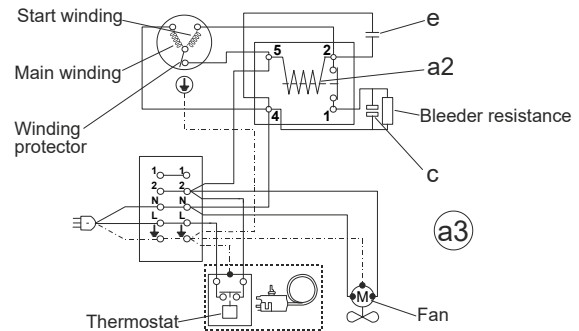
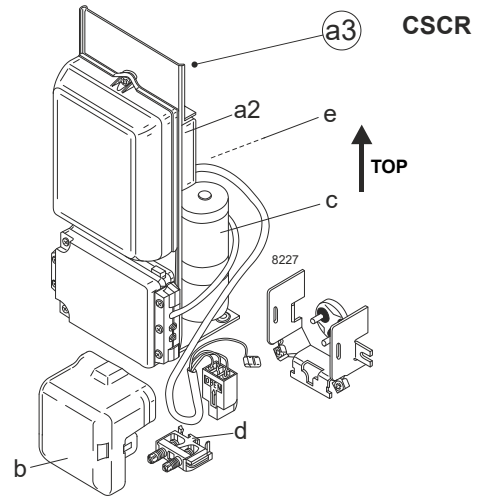

Ambient/ machine room temperatures minimum /maximum

Ambient temperature range:	10 - 38°C / 50 - 101°F
Machine room temperature range:	10 - 43°C / 50 - 110°F
Compressor cooling:	fan 3m/s

Operation Limits

Operation pressure range

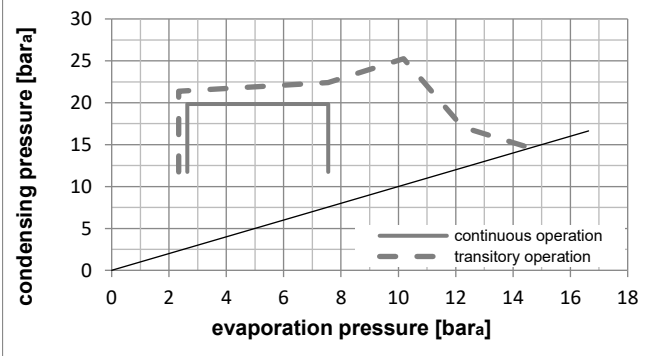
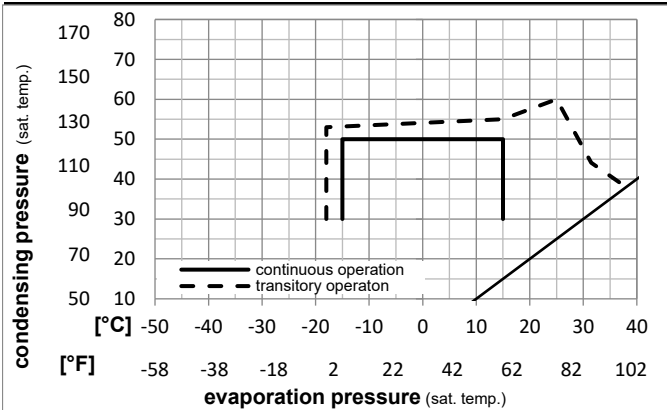

Components

a3	SC starter kit (550mm)	117-7029
b	plastic cover	103N2009
d	cord relief	103N1004

Alternative components

a3	SC starter kit (650mm)	117-7032
a3	SC starter kit (1000mm)	117-7041
a2	potential relay (RVA 4H3R341)	117-7427
c	start capacitor (80µF)	117U5373
e	run capacitor (10µF, 6.3mm)	117-7112

Model

Designation **SC15DL** **220-240V/50Hz** Conf. 2 Sales code: **104L2866**

Optimization + standard conditions

R407C, 220V/50Hz, CSCR, fan 3m/s, VDE, CCC

		Evaporating pressure (saturation temperature)				Condensing pressure (saturation temperature)			Return gas temp.			Liquid temp.			Cooling capacity			COP	EER	Power consumption			
		pe	pc	RGT	Tliq	[W]	[Btu/h]	[kcal/h]	[W/W]	[Btu/Wh]	[kcal/Wh]	P1	I	m	[W]	[A]	[kg/h]						
[°C]	[°F]																						
7,2	45	54	35	46	2069,5	7068	1781,0	2,59	8,85	2,23	798,3	3,98	44,23								ASHRAE HBP		
5	41	55	32	55	1686,7	5760	1451,6	2,16	7,38	1,86	780,5	3,90	40,21								cecomaf HBP		
5	41	50	20	50	1765,7	6030	1519,6	2,34	7,99	2,01	754,6	3,79	42,80								EN12900 HBP		
-7	20	54	35	46	1105,8	3777	951,7	1,70	5,80	1,46	650,9	3,33	23,09								ASHRAE MBP		
-10	14	55	32	55	832,6	2844	716,6	1,37	4,66	1,17	609,9	3,15	19,33								cecomaf MBP		
-10	14	45	20	45	976,4	3335	840,3	1,66	5,65	1,42	589,9	3,08	21,73								EN12900 MBP		

Performance tables

R407C, 220V/50Hz, CSCR, fan 3m/s, VDE, CCC

	pe		Cooling capacity			COP	EER	P1			I	m
	[°C]	[°F]	[W]	[Btu/h]	[kcal/h]	[W/W]	[Btu/Wh]	[kcal/Wh]	[W]	[A]	[kg/h]	
[°C / °F]	-15	5	776,8	2653	668,5	1,45	4,96	1,25	534,3	2,84	16,14	
cond. pressure	-10	14	1011,2	3453	870,2	1,71	5,85	1,48	589,9	3,08	21,12	
pc= 45/113	-5	23	1293,2	4416	1112,9	2,02	6,90	1,74	640,4	3,30	27,20	
return gas temp.	0	32	1628,6	5562	1401,6	2,37	8,11	2,04	685,8	3,50	34,52	
RGT= 32/90	5	41	2023,3	6910	1741,2	2,79	9,52	2,40	726,0	3,67	43,29	
liquid temp	10	50	2483,0	8480	2136,9	3,26	11,15	2,81	760,6	3,82	53,72	
Tliq= 45/113	15	59	3013,5	10292	2593,5	3,82	13,03	3,28	789,7	3,94	66,06	
[°C / °F]	-15	5	622,3	2125	535,6	1,15	3,92	0,99	542,0	2,85	14,36	
cond. pressure	-10	14	832,6	2844	716,6	1,37	4,66	1,17	609,9	3,15	19,33	
pc= 55/131	-5	23	1076,3	3676	926,2	1,60	5,47	1,38	672,4	3,42	25,17	
return gas temp	0	32	1359,0	4641	1169,6	1,86	6,36	1,60	729,3	3,68	32,06	
RGT= 32/90	5	41	1686,7	5760	1451,6	2,16	7,38	1,86	780,5	3,90	40,21	
liquid temp	10	50	2065,0	7052	1777,2	2,50	8,54	2,15	825,8	4,11	49,84	
Tliq= 55/131	15	59	2500,0	8538	2151,5	2,89	9,87	2,49	865,2	4,29	61,23	