

## Model

Designation	<b>SC18CNX.2</b>	220-240V/50Hz 1~	Sales code:	<b>104H8874</b>
-------------	------------------	------------------	-------------	-----------------

## Compressor design

Oil type	Polyolester	Refrigerant(s)	<b>R290, , 0</b>
Oil viscosity	22cST	Displacement	17,69cm <sup>3</sup> / 1,08cu.in
Oil quantity	550cm <sup>3</sup> / 18,6fl.oz	Compressors on pallet	80
Refr. charge - tech. limit	150g / 5,3oz		
Free gas volume comp.	1410cm <sup>3</sup> / 47,7fl.oz		
Weight	14kg / 30,9lbs		
Motor protection	1# internal		
Winding resistance main	4Ω (at 25°C)		
Winding resistance aux	13,1Ω (at 25°C)		
Max. winding temp.	125°C / 257°F		
Max. discharge temp.	130°C / 266°F		



## General - Configurations with SC18CNX.2

	<b>Conf. 1</b>
Motorconfiguration	CSIR
Power supply (nominal)	220-240V/50Hz
Number of phases	1
Voltage range	198-254V
Approvals	VDE, CCC
Starting torque	HST
Note	- / -

## Applications with SC18CNX.2

	<b>Conf. 1</b>
Refrigerant	R290
Application	LBP
System cooling	fan 3m/s
Hot gas defrost	OK
Long interval pull down	OK

## Electrical data - Configurations with SC18CNX.2

	<b>Conf. 1</b>
Starting device type	relay
Run capacitor	-/-
Start capacitor	80μF
LRA (locked rotor amps / 4s/ U(N))	19,5A
RLA (rated load amps / 1s/ U(N))	3,8A
Cut in current (U(N))	19,5A

## Model

Designation

**SC18CNX.2**

220-240V/50Hz 1~

Sales code:

**104H8874**

## Compressor dimensions

Housing	A Height	219mm / 8,62in
	B Height	213mm / 8,39in
	C Length shell	218mm / 8,58in
	D Length w. cover	255mm / 10,04in
	E Width	151mm / 5,94in

Connectors		Suction	Discharge	Process
		X	Y	Z
Diameter	[mm]	øi 8,11-8,29	øi 6,11-6,29	øi 6,11-6,29
	(i:inside, o:outside) [in]	øi 0,32-0,33	øi 0,24-0,25	øi 0,24-0,25
Material		copper	copper	copper
Horizontal angle	±2°	37°	37°	143°
Vertical angle	±2°	30°	0°	150°
Position l/h/w	[mm]	107/193/55	115/110/63	-107/193/55
	[in]	4,2/7,6/2,2	4,5/4,3/2,5	-4,2/7,6/2,2
Straight tube l.	[mm]	12	12	12
	[in]	0,5	0,5	0,5

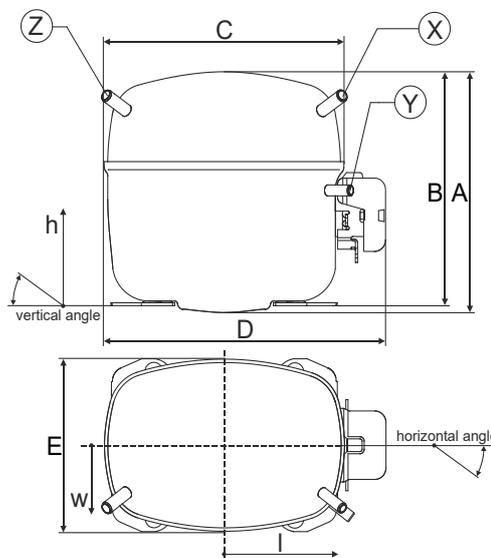

## Compressor fixation

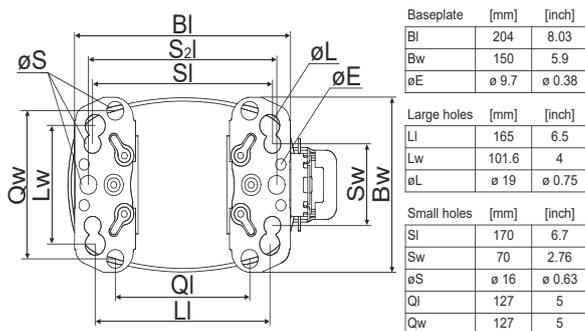

### Bolt joint

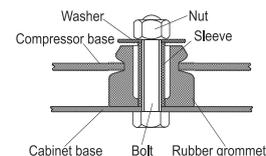

### Snap-on

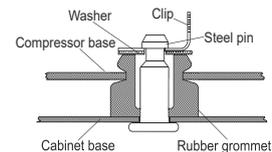

## Mounting accessories

	one comp.	multi pack
Bolt joint   M6   ø16mm	118-1917	118-1918
Bolt joint   ø1/4"   ø16mm	118-1946	
Bolt joint   ø1/4"   ø19mm	118-1949	
Snap-on   ø7,3   ø16mm	118-1947	118-1919

## Application notes

Provision for PE Grounding is located at the PE Stamp on the compressor

### Model

Designation	<b>SC18CNX.2</b>	<b>220-240V/50Hz</b>	Conf. 1	Sales code:	<b>104H8874</b>
-------------	------------------	----------------------	---------	-------------	-----------------

### Configuration

Motorconfiguration	CSIR
Power supply (nominal)	220-240V/50Hz 1~
Refrigerant	R290
Application	LBP
Voltage range	198-254V
Starting torque	HST
Approvals	VDE
	CCC

### Electrical accessories / wiring diagram

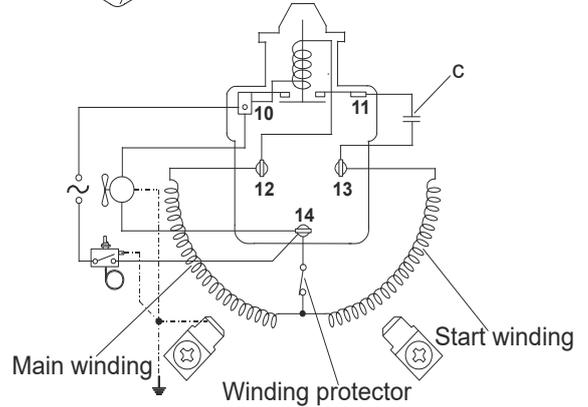
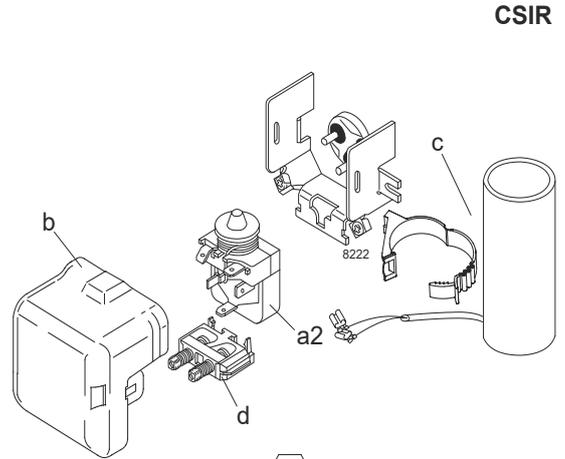

### Ambient/ machine room temperatures minimum /maximum

Ambient temperature range: 10 - 43°C / 50 - 110°F

Machine room temperature range: 10 - 48°C / 50 - 119°F

Compressor cooling: fan 3m/s

### Operation pressure range

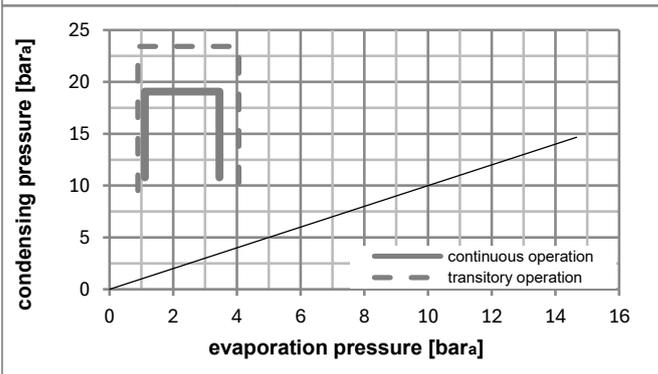
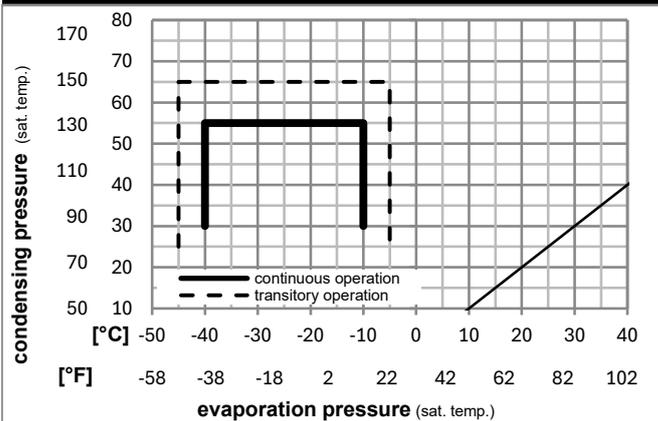

### Components

a2	relay	117U7011
c	start capacitor (80µF)	117U5017
d	cord relief	103N1004
b	plastic cover	103N2009

### Alternative components

b	plastic cover	103N2008
---	---------------	----------

### Model

Designation	<b>SC18CNX.2</b>	<b>220-240V/50Hz</b>	<b>Conf. 1</b>	Sales code:	<b>104H8874</b>
-------------	------------------	----------------------	----------------	-------------	-----------------

### Optimization + standard conditions

R290, 220V/50Hz, CSIR, fan 3m/s, VDE, CCC

	Evaporating pressure (saturation temperature)				Cooling capacity			COP	EER	P1	Power consumption		ASHRAE LBP	
	pe	pc	RGT	Tliq	[W]	[Btu/h]	[kcal/h]				I	m		
	[°C]	[°F]	[°C]	[°F]	[W]	[Btu/h]	[kcal/h]	[W/W]	[Btu/Wh]	[kcal/Wh]	[W]	[A]	[kg/h]	
	-23	54	32	32	795,3	2716	684,5	1,30	4,45	1,12	609,8	3,88	8,05	ASHRAE LBP
	-10	130	90	90										
	-25	55	32	55	587,0	2005	505,2	1,00	3,41	0,86	587,5	3,82	7,31	cecomaf LBP
	-13	131	90	131										
	-35	40	20	40	429,8	1468	369,9	1,01	3,45	0,87	425,0	3,20	4,91	EN12900 LBP
	-31	104	68	104										
	-23	49	4,4	49	640,3	2187	551,0	1,11	3,79	0,96	576,7	3,66	8,87	ARI540 LBP
	-10	120	40	120										
	-23	41	32	32	848,2	2897	729,9	1,57	5,36	1,35	540,1	3,54	8,59	AHAM LBP
	-10	105	90	90										
	-35	45	32	45	383,6	1310	330,1	0,92	3,14	0,79	417,0	3,15	4,30	opt
	-31	113	90	113										

### Performance tables

R290, 220V/50Hz, CSIR, fan 3m/s, VDE, CCC

	pe		Cooling capacity			COP	EER		P1	I	m
	[°C]	[°F]	[W]	[Btu/h]	[kcal/h]		[Btu/Wh]	[kcal/Wh]			
[°C / °F]	-40	-40	244,2	834	210,1	0,72	2,47	0,62	337,1	2,96	2,73
cond. pressure	-35	-31	383,6	1310	330,1	0,92	3,14	0,79	417,0	3,15	4,30
pc= 45/113	-30	-22	530,7	1812	456,7	1,10	3,74	0,94	484,0	3,34	5,96
return gas temp.	-25	-13	689,4	2354	593,3	1,27	4,35	1,10	540,9	3,52	7,77
RGT= 32/90	-20	-4	863,5	2949	743,1	1,46	4,99	1,26	591,0	3,69	9,78
liquid temp	-15	5	1056,9	3609	909,6	1,66	5,67	1,43	637,1	3,85	12,02
Tliq= 45/113	-10	14	1273,4	4349	1095,9	1,87	6,37	1,61	682,3	4,01	14,57
[°C / °F]	-40	-40	135,5	463	116,6	0,47	1,60	0,40	289,9	3,03	1,67
cond. pressure	-35	-31	274,8	939	236,5	0,68	2,32	0,59	403,8	3,30	3,40
pc= 55/131	-30	-22	424,0	1448	364,9	0,84	2,88	0,73	502,0	3,57	5,26
return gas temp	-25	-13	587,0	2005	505,2	1,00	3,41	0,86	587,5	3,82	7,31
RGT= 32/90	-20	-4	767,6	2622	660,6	1,16	3,95	1,00	663,3	4,07	9,60
liquid temp	-15	5	969,7	3312	834,5	1,32	4,52	1,14	732,4	4,31	12,19
Tliq= 55/131	-10	14	1197,1	4088	1030,3	1,50	5,12	1,29	797,8	4,55	15,14