

Model

Designation	SC18MFX	220-240V/50Hz 1~ 208-230V/60Hz 1~	Sales code:	104G8804
-------------	----------------	--	-------------	-----------------

Compressor design

Oil type	Polyolester	Refrigerant(s)	R134a, R513A
Oil viscosity	22cST	Displacement	17,69cm ³ / 1,08cu.in
Oil quantity	550cm ³ / 18,6fl.oz	Compressors on pallet	80
Refr. charge - tech. limit	1300g / 45,9oz		
Free gas volume comp.	1460cm ³ / 49,4fl.oz		
Weight	13,8kg / 30,4lbs		
Motor protection	1# internal		
Winding resistance main	3,7Ω (at 25°C)		
Winding resistance aux	14Ω (at 25°C)		
Max. winding temp.	125°C / 257°F		
Max. discharge temp.	130°C / 266°F		



General - Configurations with SC18MFX

	Conf. 1	Conf. 2	Conf. 3	Conf. 4	Conf. 5
Motorconfiguration	CSIR	CSCR	CSCR	CSIR	CSCR
Power supply (nominal)	220-240V/50Hz	220-240V/50Hz	208-230V/60Hz	220-240V/50Hz	208-230V/60Hz
Number of phases	1	1	1	1	1
Voltage range	187-254V	187-254V	187-254V	187-254V	187-254V
Approvals	CCC, EAC, VDE	CCC, EAC, VDE	CCC, EAC, VDE	CCC, EAC, VDE	CCC, EAC, VDE
Starting torque	HST	HST	HST	HST	HST
Note	- / -				

Applications with SC18MFX

	Conf. 1	Conf. 2	Conf. 3	Conf. 4	Conf. 5
Refrigerant	R134a	R134a	R134a	R513A	R513A
Application	MBP	MBP	MBP	MBP	MBP
System cooling	fan 3m/s	fan 3m/s	fan 3m/s	fan 3m/s	fan 3m/s
Hot gas defrost	OK	OK	OK	OK	OK
Long interval pull down	OK	OK	OK	OK	OK

Electrical data - Configurations with SC18MFX

	Conf. 1	Conf. 2	Conf. 3	Conf. 4	Conf. 5
Starting device type	relay	relay	relay	relay	relay
Run capacitor	-/-	10μF	10μF	-/-	10μF
Start capacitor	80μF	80μF	80μF	80μF	80μF
LRA (locked rotor amps / 4s)	20,43A	20,43A	19A	20,43A	19A
RLA (rated load amps / 1s)	3,9A	4,2A	3,5A	3,9A	3,5A
Cut in current	20,43A	20,43A	19A	20,43A	19A

Model

Designation **SC18MFX** 220-240V/50Hz 1~ 208-230V/60Hz 1~ Sales code: **104G8804**

Compressor dimensions

Housing	A Height	219mm / 8,62in
	B Height	213mm / 8,39in
	C Length shell	218mm / 8,58in
	D Length w. cover	255mm / 10,04in
	E Width	151mm / 5,94in

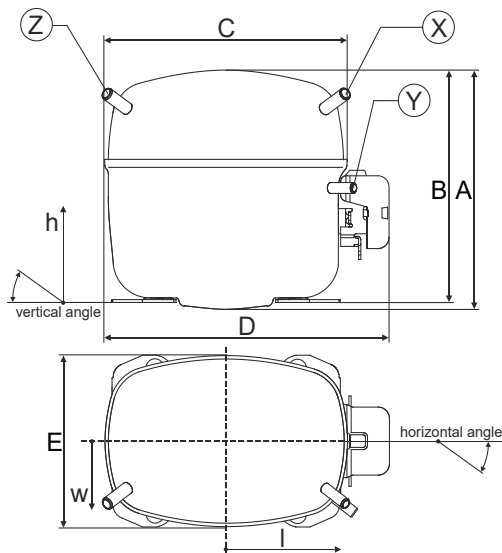

Connectors	Suction		Discharge		Process	
	X		Y		Z	
Diameter [mm]	øi 10,11-10,29		øi 6,11-6,29		øi 6,11-6,29	
(i:inside, o:outside) [in]	øi 0,4-0,41		øi 0,24-0,25		øi 0,24-0,25	
Material	copper		copper		copper	
Horizontal angle ±2°	37°		37°		143°	
Vertical angle ±2°	30°		0°		150°	
Position l/h/w [mm]	107/193/55		115/110/63		-107/193/55	
[in]	4,2/7,6/2,2		4,5/4,3/2,5		-4,2/7,6/2,2	
Straight tube l. [mm]	12		12		12	
[in]	0,5		0,5		0,5	

Compressor fixation

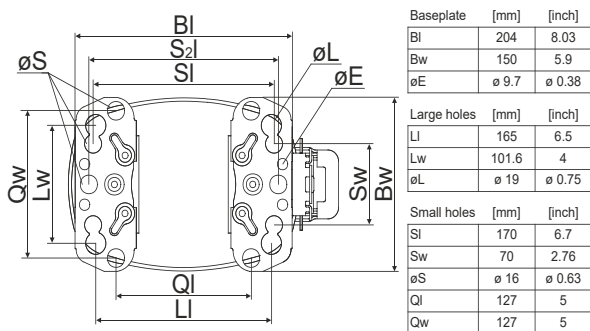

Bolt joint

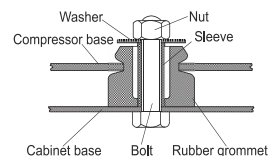

Snap-on

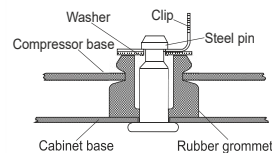

Mounting accessories

	one comp.	multi pack
Bolt joint M6 ø16mm	118-1917	118-1918
Bolt joint ø1/4" ø16mm	118-1946	
Bolt joint ø1/4" ø19mm	118-1949	
Snap-on ø7,3 ø16mm	118-1947	118-1919

Application notes

Provision for PE Grounding is located at the PE Stamp on the compressor

Model

Designation	SC18MFX	220-240V/50Hz	Conf. 1	Sales code:	104G8804
-------------	----------------	----------------------	---------	-------------	-----------------

Configuration

Motorconfiguration	CSIR
Power supply (nominal)	220-240V/50Hz 1~
Refrigerant	R134a
Application	MBP
Voltage range	187-254V
Starting torque	HST
Approvals	CCC
	EAC
	VDE

Electrical accessories / wiring diagram

CSIR

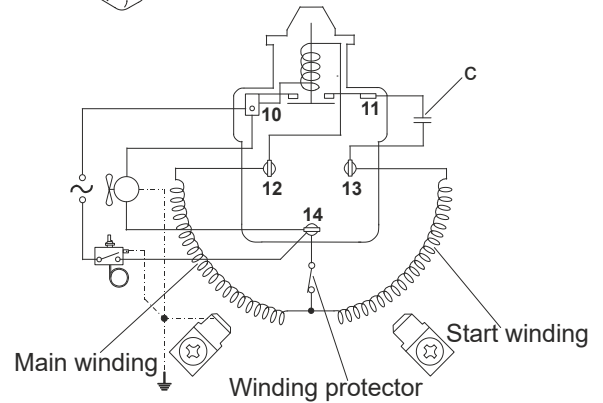
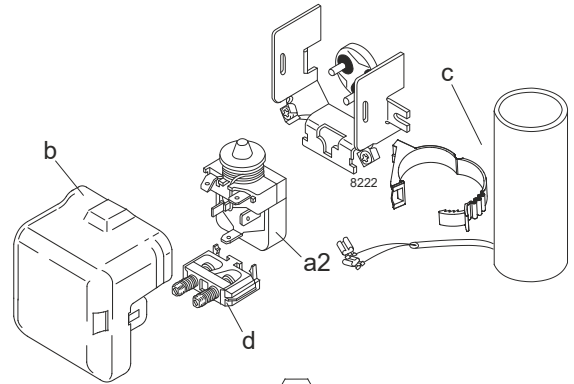

Ambient/ machine room temperatures minimum /maximum

Ambient temperature range: 10 - 43°C / 50 - 110°F

Machine room temperature range: 10 - 48°C / 50 - 119°F

Compressor cooling: fan 3m/s

Operation Limits

Operation pressure range

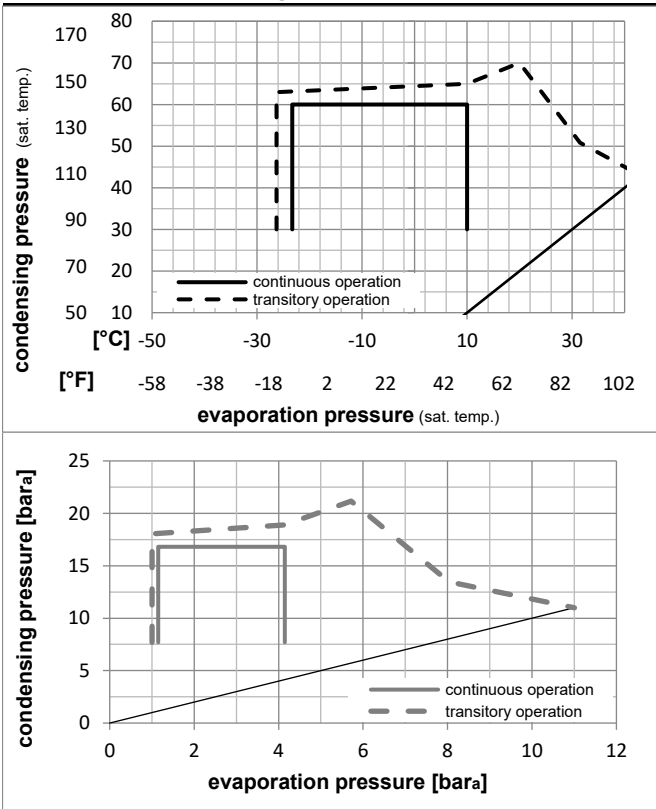

Components

a2	relay	117U6019
c	start capacitor (80µF)	117U5017
d	cord relief	103N1004
b	plastic cover	103N2008

Alternative components

a2	relay	117U6019
c	start capacitor i-pack 40# (80µF)	117U5067
d	cord relief	103N1004
b	plastic cover	103N2008

Model

Designation **SC18MFX** **220-240V/50Hz** Conf. 1 Sales code: **104G8804**

Optimization + standard conditions

R134a, 220V/50Hz, CSIR, fan 3m/s, CCC, EAC, VDE

Evaporating pressure (saturation temperature)				Condensing pressure (saturation temperature)			Return gas temp.			Liquid temp.			Cooling capacity			COP	EER	Power consumption			Ref. mass flow m	ASHRAE MBP
pe	pc	RGT	Tliq	[W]	[Btu/h]	[kcal/h]	[W/W]	[Btu/Wh]	[kcal/Wh]	P1	I	[W]	[A]	[kg/h]								
[°C]	-7	54	35	46	917,1	3132	789,3	1,63	5,56	1,40	563,3	3,56	20,01									
[°F]	20	130	95	115																		
[°C]	-10	55	32	55	708,6	2420	609,8	1,34	4,59	1,16	527,1	3,43	17,13	cecomaf MBP								
[°F]	14	131	90	131																		
[°C]	-10	45	20	45	793,2	2709	682,6	1,59	5,43	1,37	498,5	3,31	18,57	EN12900 MBP								
[°F]	14	113	68	113																		
[°C]	-7	49	18	49	867,6	2963	746,7	1,60	5,46	1,38	542,7	3,48	21,43	ARI540 MBP								
[°F]	20	120	65	120																		
[°C]	-10	45	32	45	822,9	2810	708,2	1,65	5,64	1,42	498,5	3,31	18,01	opt								
[°F]	14	113	90	113																		
[°C]	-25	45	32	45	376,3	1285	323,9	1,04	3,55	0,89	362,3	2,84	8,15	opt								
[°F]	-13	113	90	113																		

Performance tables

R134a, 220V/50Hz, CSIR, fan 3m/s, CCC, EAC, VDE

	pe		Cooling capacity			COP	EER		P1	I	m
	[°C]	[°F]	[W]	[Btu/h]	[kcal/h]	[W/W]	[Btu/Wh]	[kcal/Wh]	[W]	[A]	[kg/h]
[°C / °F]	-23	-10	415,2	1418	357,3	1,10	3,75	0,95	377,7	2,89	9,00
cond. pressure	-20	-4	498,3	1702	428,9	1,22	4,18	1,05	407,6	2,99	10,83
pc= 45/113	-15	5	645,8	2206	555,8	1,43	4,87	1,23	452,8	3,15	14,08
return gas temp.	-10	14	822,9	2810	708,2	1,65	5,64	1,42	498,5	3,31	18,01
RGT= 32/90	0	32	1282,4	4380	1103,6	2,16	7,39	1,86	592,8	3,67	28,36
liquid temp	5	41	1572,9	5372	1353,7	2,45	8,36	2,11	642,3	3,86	35,02
Tliq= 45/113	10	50	1909,5	6521	1643,4	2,75	9,40	2,37	694,0	4,06	42,85
[°C / °F]	-23	-10	350,7	1198	301,8	0,93	3,18	0,80	376,7	2,91	8,39
cond. pressure	-20	-4	424,0	1448	364,9	1,02	3,50	0,88	413,8	3,04	10,17
pc= 55/131	-15	5	553,4	1890	476,2	1,18	4,02	1,01	470,2	3,23	13,32
return gas temp	-10	14	708,6	2420	609,8	1,34	4,59	1,16	527,1	3,43	17,13
RGT= 32/90	0	32	1112,8	3801	957,7	1,73	5,90	1,49	644,0	3,86	27,22
liquid temp	5	41	1370,1	4679	1179,1	1,94	6,64	1,67	705,0	4,09	33,76
Tliq= 55/131	10	50	1669,6	5702	1436,9	2,17	7,42	1,87	768,3	4,32	41,50

Model

Designation	SC18MFX	220-240V/50Hz	Conf. 2	Sales code:	104G8804
-------------	----------------	----------------------	---------	-------------	-----------------

Configuration

Motorconfiguration	CSCR
Power supply (nominal)	220-240V/50Hz 1~
Refrigerant	R134a
Application	MBP
Voltage range	187-254V
Starting torque	HST
Approvals	CCC
	EAC
	VDE

Electrical accessories / wiring diagram

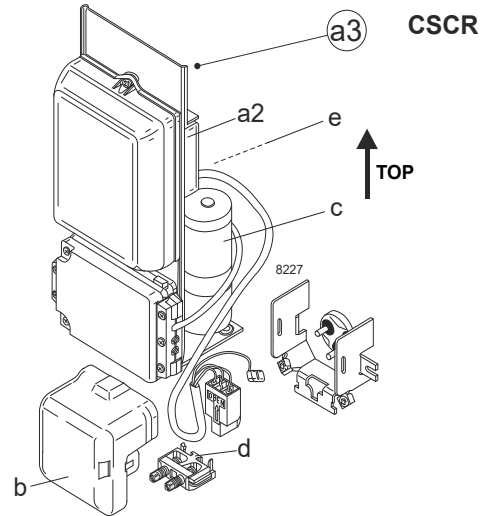

Ambient/ machine room temperatures minimum /maximum

Ambient temperature range: 10 - 43°C / 50 - 110°F

Machine room temperature range: 10 - 48°C / 50 - 119°F

Compressor cooling: fan 3m/s

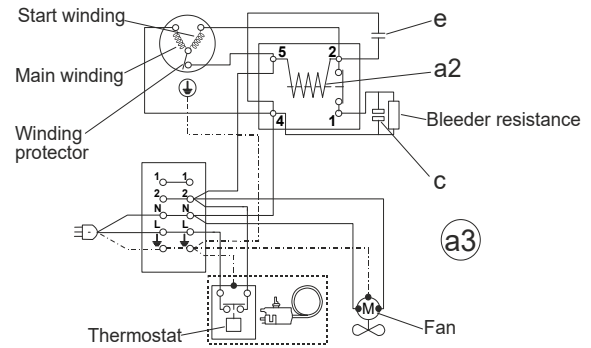

Operation Limits

Operation pressure range

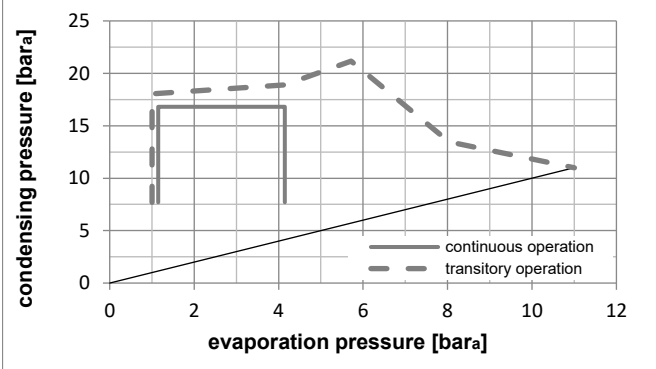
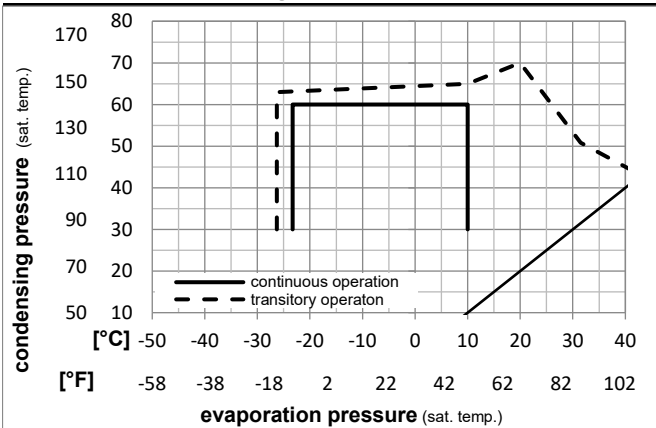

Components

a3	SC starter kit (550mm)	117-7027
b	plastic cover	103N2008
d	cord relief	103N1004

Alternative components

a3	SC starter kit (1000mm)	117-7040
b	plastic cover	103N2008
d	cord relief	103N1004

Model

Designation	SC18MFX	220-240V/50Hz	Conf. 2	Sales code:	104G8804
-------------	----------------	----------------------	----------------	-------------	-----------------

Optimization + standard conditions

R134a, 220V/50Hz, CSCR, fan 3m/s, CCC, EAC, VDE

		Evaporating pressure (saturation temperature)				Condensing pressure (saturation temperature)						Power consumption			
		Return gas temp.				Liquid temp.						Current consumption			Ref. mass flow
		Cooling capacity				COP		EER		P1	I	m			
		pe	pc	RGT	Tliq	[W]	[Btu/h]	[kcal/h]	[W/W]	[Btu/Wh]	[kcal/Wh]	[W]	[A]	[kg/h]	
[°C]	-7	54	35	46	935,9	3196	805,5	1,74	5,93	1,49	539,3	2,81	20,42	ASHRAE MBP	
[°F]	20	130	95	115											
[°C]	-10	55	32	55	722,2	2467	621,5	1,42	4,86	1,23	507,3	2,67	17,46	cecomaf MBP	
[°F]	14	131	90	131											
[°C]	-10	45	20	45	811,0	2770	698,0	1,69	5,77	1,45	480,1	2,56	18,98	EN12900 MBP	
[°F]	14	113	68	113											
[°C]	-7	49	18	49	887,1	3029	763,4	1,70	5,82	1,47	520,7	2,73	21,91	ARI540 MBP	
[°F]	20	120	65	120											
[°C]	-10	45	32	45	841,4	2874	724,1	1,75	5,99	1,51	480,1	2,56	18,41	opt	
[°F]	14	113	90	113											
[°C]	-25	45	32	45	384,1	1312	330,5	1,10	3,76	0,95	349,1	2,08	8,32	opt	
[°F]	-13	113	90	113											

Performance tables

R134a, 220V/50Hz, CSCR, fan 3m/s, CCC, EAC, VDE

	pe		Cooling capacity			COP		EER		P1	I	m
	[°C]	[°F]	[W]	[Btu/h]	[kcal/h]	[W/W]	[Btu/Wh]	[kcal/Wh]	[W]	[A]	[kg/h]	
[°C / °F]	-23	-10	424,0	1448	364,9	1,16	3,97	1,00	365,1	2,13	9,19	
cond. pressure	-20	-4	509,2	1739	438,2	1,29	4,40	1,11	395,1	2,23	11,06	
pc= 45/113	-15	5	660,3	2255	568,3	1,51	5,14	1,30	438,5	2,39	14,39	
return gas temp.	-10	14	841,4	2874	724,1	1,75	5,99	1,51	480,1	2,56	18,41	
RGT= 32/90	0	32	1310,2	4475	1127,6	2,33	7,97	2,01	561,5	2,92	28,97	
liquid temp	5	41	1606,1	5485	1382,2	2,66	9,10	2,29	602,9	3,11	35,76	
Tliq= 45/113	10	50	1948,4	6654	1676,8	3,02	10,30	2,60	645,8	3,31	43,72	
[°C / °F]	-23	-10	355,4	1214	305,9	0,98	3,35	0,84	362,4	2,13	8,51	
cond. pressure	-20	-4	430,4	1470	370,4	1,08	3,67	0,93	400,3	2,26	10,32	
pc= 55/131	-15	5	563,1	1923	484,6	1,24	4,23	1,06	455,0	2,46	13,55	
return gas temp	-10	14	722,2	2467	621,5	1,42	4,86	1,23	507,3	2,67	17,46	
RGT= 32/90	0	32	1136,5	3881	978,1	1,87	6,39	1,61	607,4	3,11	27,80	
liquid temp	5	41	1399,9	4781	1204,7	2,13	7,28	1,83	657,1	3,34	34,50	
Tliq= 55/131	10	50	1706,2	5827	1468,4	2,41	8,24	2,08	707,5	3,58	42,41	

Model

Designation	SC18MFX	208-230V/60Hz	Conf. 3	Sales code:	104G8804
-------------	----------------	----------------------	----------------	-------------	-----------------

Configuration

Motorconfiguration	CSCR
Power supply (nominal)	208-230V/60Hz 1~
Refrigerant	R134a
Application	MBP
Voltage range	187-254V
Starting torque	HST
Approvals	CCC
	EAC
	VDE

Electrical accessories / wiring diagram

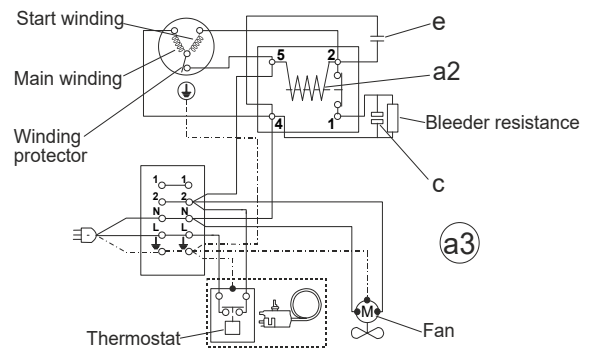
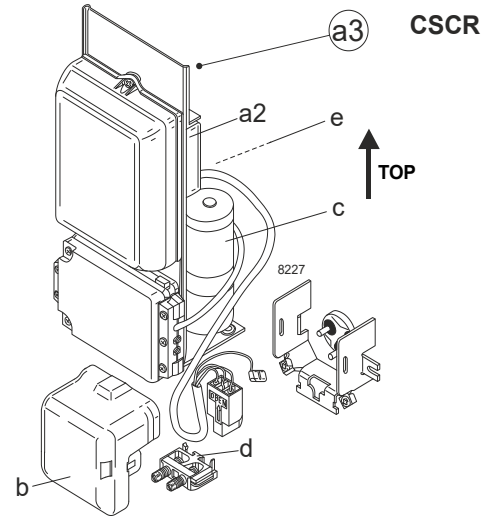

Ambient/ machine room temperatures minimum /maximum

Ambient temperature range: 10 - 43°C / 50 - 110°F

Machine room temperature range: 10 - 48°C / 50 - 119°F

Compressor cooling: fan 3m/s

Operation Limits

Operation pressure range

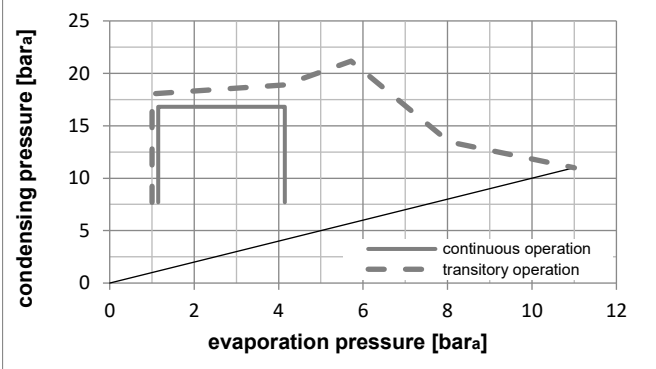
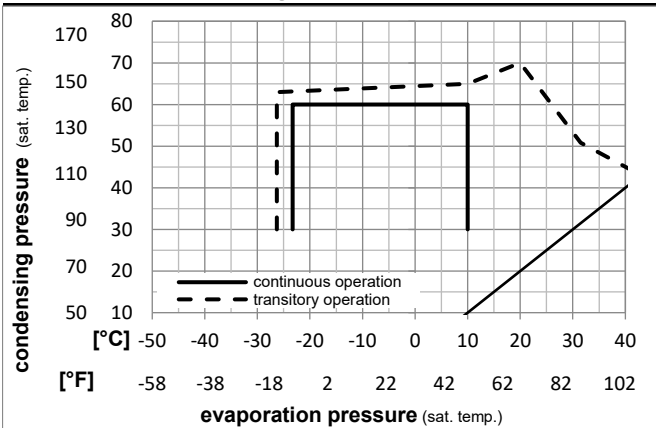

Components

a3	SC starter kit (550mm)	117-7027
b	plastic cover	103N2008
d	cord relief	103N1004

Alternative components

a3	SC starter kit (1000mm)	117-7040
b	plastic cover	103N2008
d	cord relief	103N1004

Model

Designation	SC18MFX	208-230V/60Hz	Conf. 3	Sales code:	104G8804
-------------	----------------	----------------------	----------------	-------------	-----------------

Optimization + standard conditions

R134a, 220V/60Hz, CSCR, fan 3m/s, CCC, EAC, VDE

		Evaporating pressure (saturation temperature)				Condensing pressure (saturation temperature)						Power consumption			
		Return gas temp.				Liquid temp.						Current consumption			Ref. mass flow
		Cooling capacity				COP		EER		P1	I	m			
		pe	pc	RGT	Tliq	[W]	[Btu/h]	[kcal/h]	[W/W]	[Btu/Wh]	[kcal/Wh]	[W]	[A]	[kg/h]	
[°C]	-7	54	35	46	1096,6	3745	943,8	1,75	5,96	1,50	628,2	2,82	23,93	ASHRAE MBP	
[°F]	20	130	95	115											
[°C]	-10	55	32	55	850,5	2905	732,0	1,45	4,97	1,25	585,0	2,63	20,57	cecomaf MBP	
[°F]	14	131	90	131											
[°C]	-10	45	20	45	947,7	3237	815,6	1,71	5,83	1,47	555,3	2,48	22,18	EN12900 MBP	
[°F]	14	113	68	113											
[°C]	-7	49	18	49	1035,2	3536	890,9	1,70	5,81	1,46	608,7	2,73	25,57	ARI540 MBP	
[°F]	20	120	65	120											
[°C]	-10	45	32	45	983,3	3358	846,2	1,77	6,05	1,52	555,3	2,48	21,52	opt	
[°F]	14	113	90	113											
[°C]	-25	45	32	45	456,4	1559	392,8	1,16	3,97	1,00	392,3	1,75	9,89	opt	
[°F]	-13	113	90	113											

Performance tables

R134a, 220V/60Hz, CSCR, fan 3m/s, CCC, EAC, VDE

	pe		Cooling capacity			COP	EER		P1	I	m
	[°C]	[°F]	[W]	[Btu/h]	[kcal/h]	[W/W]	[Btu/Wh]	[kcal/Wh]	[W]	[A]	[kg/h]
[°C / °F]	-23	-10	502,8	1717	432,7	1,23	4,19	1,06	409,6	1,83	10,90
cond. pressure	-20	-4	601,5	2054	517,7	1,35	4,63	1,17	444,1	1,98	13,07
pc= 45/113	-15	5	775,5	2649	667,4	1,56	5,31	1,34	498,5	2,23	16,91
return gas temp.	-10	14	983,3	3358	846,2	1,77	6,05	1,52	555,3	2,48	21,52
RGT= 32/90	0	32	1519,2	5188	1307,4	2,25	7,69	1,94	675,0	3,04	33,60
liquid temp	5	41	1857,0	6342	1598,2	2,52	8,60	2,17	737,3	3,34	41,34
Tliq= 45/113	10	50	2248,0	7677	1934,6	2,81	9,59	2,42	800,9	3,65	50,44
[°C / °F]	-23	-10	426,8	1457	367,3	1,01	3,46	0,87	421,5	1,88	10,21
cond. pressure	-20	-4	514,5	1757	442,8	1,12	3,82	0,96	459,6	2,06	12,34
pc= 55/131	-15	5	668,0	2281	574,9	1,28	4,38	1,10	520,5	2,34	16,08
return gas temp	-10	14	850,5	2905	732,0	1,45	4,97	1,25	585,0	2,63	20,57
RGT= 32/90	0	32	1322,1	4515	1137,8	1,83	6,24	1,57	724,0	3,25	32,34
liquid temp	5	41	1620,8	5535	1394,9	2,03	6,94	1,75	797,8	3,58	39,94
Tliq= 55/131	10	50	1967,9	6721	1693,6	2,25	7,69	1,94	874,3	3,93	48,92

Model

Designation	SC18MFX	220-240V/50Hz	Conf. 4	Sales code:	104G8804
-------------	----------------	----------------------	---------	-------------	-----------------

Configuration

Motorconfiguration	CSIR
Power supply (nominal)	220-240V/50Hz 1~
Refrigerant	R513A
Application	MBP
Voltage range	187-254V
Starting torque	HST
Approvals	CCC
	EAC
	VDE

Electrical accessories / wiring diagram

CSIR

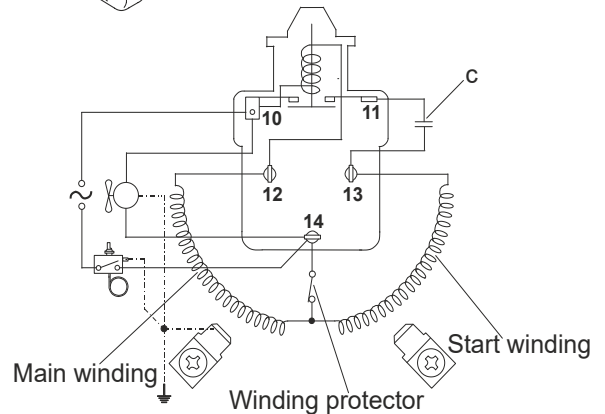
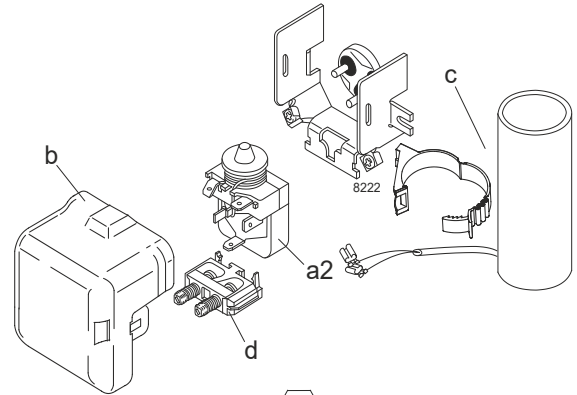

Ambient/ machine room temperatures minimum /maximum

Ambient temperature range: 10 - 43°C / 50 - 110°F

Machine room temperature range: 10 - 48°C / 50 - 119°F

Compressor cooling: fan 3m/s

Operation Limits

Operation pressure range

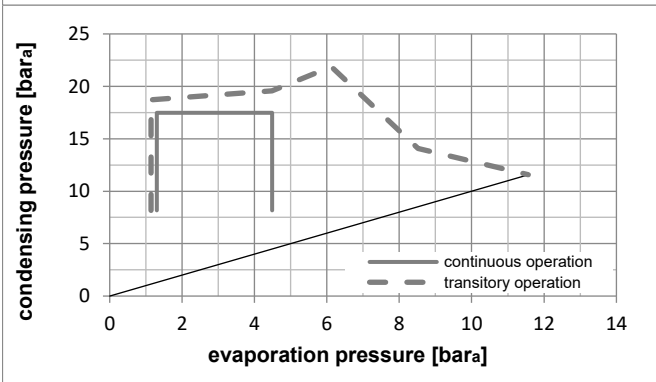
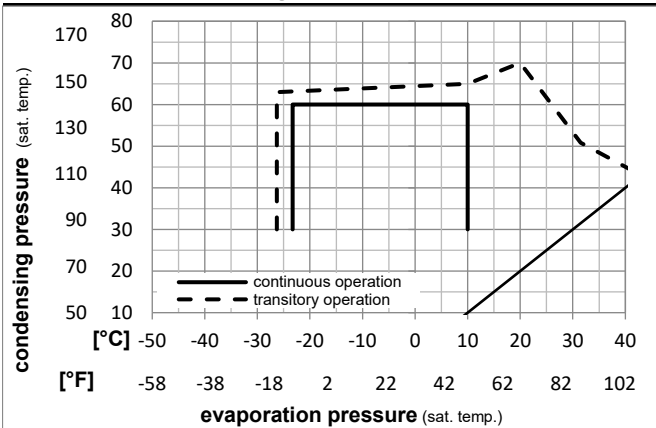

Components

a2	relay	117U6019
c	start capacitor (80µF)	117U5017
d	cord relief	103N1004
b	plastic cover	103N2008

Alternative components

a2	relay	117U6019
c	start capacitor i-pack 40# (80µF)	117U5067
d	cord relief	103N1004
b	plastic cover	103N2008

Model

Designation	SC18MFX	220-240V/50Hz	Conf. 4	Sales code:	104G8804
-------------	----------------	----------------------	----------------	-------------	-----------------

Optimization + standard conditions

R513A, 220V/50Hz, CSIR, fan 3m/s, CCC, EAC, VDE

		Evaporating pressure (saturation temperature)				Condensing pressure (saturation temperature)						Power consumption					
		Return gas temp.		Liquid temp.		Cooling capacity		COP	EER		P1	I	Ref. mass flow				
		pe	pc	RGT	Tliq	[W]	[Btu/h]	[kcal/h]	[W/W]	[Btu/Wh]	[kcal/Wh]	[W]	[A]	[kg/h]			
[°C]	[°F]	[°C]	[°F]	[°C]	[°F]												
-7	20	54	130	35	95	46	115	963,3	3290	829,1	1,61	5,48	1,38	600,0	3,71	23,60	ASHRAE MBP
-10	14	55	131	32	90	55	131	736,0	2514	633,4	1,30	4,45	1,12	564,8	3,59	20,35	cecomaf MBP
-10	14	45	113	20	68	45	113	829,5	2833	713,9	1,56	5,31	1,34	533,3	3,47	21,99	EN12900 MBP
-7	20	49	120	18	65	49	120	895,7	3059	770,8	1,55	5,30	1,33	577,5	3,63	25,24	ARI540 MBP
-10	14	45	113	32	90	45	113	867,4	2962	746,5	1,63	5,56	1,40	533,3	3,47	21,33	opt
-25	-13	45	113	32	90	45	113	411,2	1404	353,9	1,03	3,52	0,89	398,7	2,99	10,02	opt

Performance tables

R513A, 220V/50Hz, CSIR, fan 3m/s, CCC, EAC, VDE

	pe		Cooling capacity			COP	EER		P1	I	m
	[°C]	[°F]	[W]	[Btu/h]	[kcal/h]	[W/W]	[Btu/Wh]	[kcal/Wh]	[W]	[A]	[kg/h]
[°C / °F]	-23	-10	451,3	1541	388,4	1,09	3,72	0,94	414,4	3,04	11,01
cond. pressure	-20	-4	536,7	1833	461,9	1,21	4,13	1,04	444,4	3,15	13,11
pc= 45/113	-15	5	687,6	2348	591,7	1,41	4,80	1,21	489,0	3,31	16,85
return gas temp.	-10	14	867,4	2962	746,5	1,63	5,56	1,40	533,3	3,47	21,33
RGT= 32/90	0	32	1329,8	4541	1144,4	2,13	7,27	1,83	624,3	3,80	32,98
liquid temp	5	41	1619,9	5532	1394,1	2,41	8,23	2,07	672,5	3,97	40,40
Tliq= 45/113	10	50	1954,3	6674	1681,9	2,70	9,22	2,32	723,6	4,16	49,07
[°C / °F]	-23	-10	377,9	1290	325,2	0,91	3,11	0,78	415,6	3,05	10,36
cond. pressure	-20	-4	451,7	1543	388,7	1,00	3,41	0,86	452,9	3,18	12,40
pc= 55/131	-15	5	581,4	1986	500,4	1,14	3,90	0,98	508,9	3,38	16,02
return gas temp	-10	14	736,0	2514	633,4	1,30	4,45	1,12	564,8	3,59	20,35
RGT= 32/90	0	32	1135,0	3876	976,8	1,67	5,70	1,44	679,5	4,00	31,70
liquid temp	5	41	1387,1	4737	1193,8	1,87	6,40	1,61	739,9	4,22	38,98
Tliq= 55/131	10	50	1679,4	5736	1445,3	2,09	7,14	1,80	803,3	4,44	47,55

Model

Designation	SC18MFX	208-230V/60Hz	Conf. 5	Sales code:	104G8804
-------------	----------------	----------------------	----------------	-------------	-----------------

Configuration

Motorconfiguration	CSCR
Power supply (nominal)	208-230V/60Hz 1~
Refrigerant	R513A
Application	MBP
Voltage range	187-254V
Starting torque	HST
Approvals	CCC
	EAC
	VDE

Electrical accessories / wiring diagram

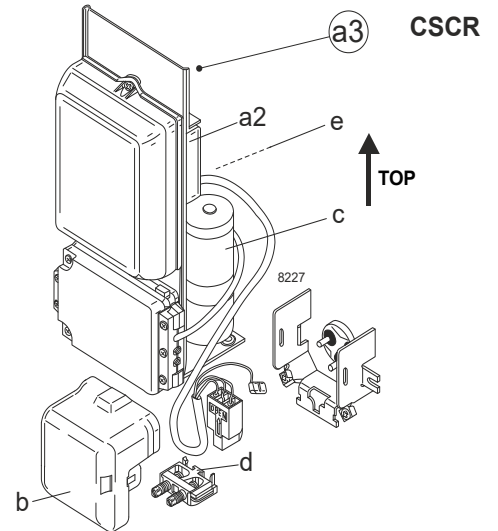

Ambient/ machine room temperatures minimum /maximum

Ambient temperature range: 10 - 43°C / 50 - 110°F

Machine room temperature range: 10 - 48°C / 50 - 119°F

Compressor cooling: fan 3m/s

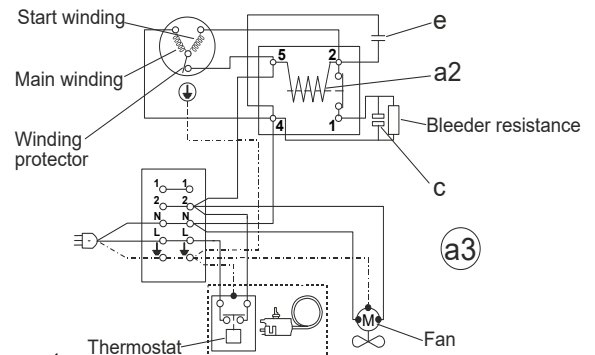

Operation Limits

Operation pressure range

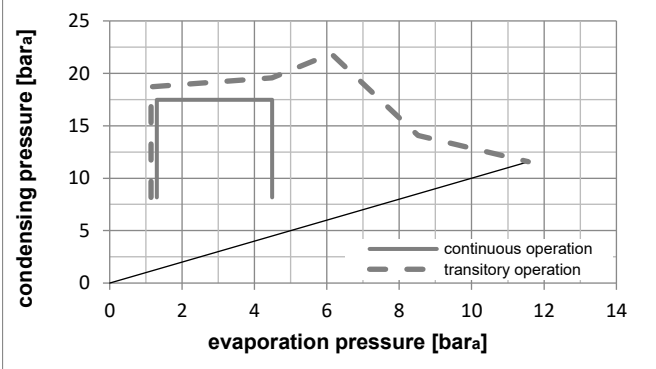
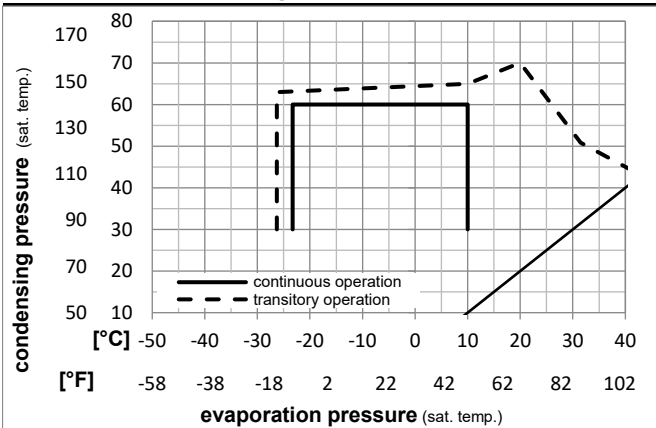

Components

a3	SC starter kit (550mm)	117-7027
b	plastic cover	103N2008
d	cord relief	103N1004

Alternative components

a3	SC starter kit (1000mm)	117-7040
b	plastic cover	103N2008
d	cord relief	103N1004

Model

Designation **SC18MFX** **208-230V/60Hz** Conf. 5 Sales code: **104G8804**

Optimization + standard conditions

R513A, 220V/60Hz, CSCR, fan 3m/s, CCC, EAC, VDE

		Evaporating pressure (saturation temperature)				Condensing pressure (saturation temperature)					Power consumption			
		Return gas temp.				Liquid temp.					Current consumption		Ref. mass flow	
		Cooling capacity				COP	EER	P1		I	m			
		[W]	[Btu/h]	[kcal/h]	[W/W]	[Btu/Wh]	[kcal/Wh]	[W]	[A]	[kg/h]				
pe	pc	RGT	Tliq											
[°C]	[°C]	[°C]	[°C]											
[°F]	[°F]	[°F]	[°F]											
-7	54	35	46	1153,1	3938	992,4	1,73	5,92	1,49	665,7	3,10	28,24	ASHRAE MBP	
20	130	95	115											
-10	55	32	55	884,3	3020	761,1	1,42	4,85	1,22	622,9	2,90	24,45	cecomaf MBP	
14	131	90	131											
-10	45	20	45	992,1	3388	853,8	1,68	5,75	1,45	589,5	2,75	26,29	EN12900 MBP	
14	113	68	113											
-7	49	18	49	1069,7	3653	920,6	1,66	5,67	1,43	644,3	3,00	30,14	ARI540 MBP	
20	120	65	120											
-10	45	32	45	1037,4	3543	892,8	1,76	6,01	1,51	589,5	2,75	25,51	opt	
14	113	90	113											
-25	45	32	45	499,2	1705	429,6	1,17	4,01	1,01	425,4	1,99	12,17	opt	
-13	113	90	113											

Performance tables

R513A, 220V/60Hz, CSCR, fan 3m/s, CCC, EAC, VDE

	pe		Cooling capacity			COP	EER		P1	I	m
	[°C]	[°F]	[W]	[Btu/h]	[kcal/h]	[W/W]	[Btu/Wh]	[kcal/Wh]	[W]	[A]	[kg/h]
[°C / °F]	-23	-10	547,1	1868	470,8	1,24	4,22	1,06	442,9	2,07	13,34
cond. pressure	-20	-4	648,6	2215	558,2	1,36	4,64	1,17	477,6	2,23	15,85
pc= 45/113	-15	5	826,5	2823	711,3	1,55	5,30	1,34	532,4	2,49	20,25
return gas temp.	-10	14	1037,4	3543	892,8	1,76	6,01	1,51	589,5	2,75	25,51
RGT= 32/90	0	32	1576,7	5385	1356,9	2,22	7,59	1,91	709,1	3,30	39,11
liquid temp	5	41	1914,1	6537	1647,3	2,48	8,48	2,14	771,1	3,58	47,74
Tliq= 45/113	10	50	2302,9	7865	1981,9	2,76	9,43	2,38	834,0	3,87	57,82
[°C / °F]	-23	-10	460,2	1572	396,1	1,00	3,42	0,86	459,6	2,15	12,61
cond. pressure	-20	-4	548,7	1874	472,2	1,10	3,77	0,95	497,6	2,33	15,07
pc= 55/131	-15	5	702,5	2399	604,6	1,26	4,30	1,08	558,4	2,61	19,35
return gas temp	-10	14	884,3	3020	761,1	1,42	4,85	1,22	622,9	2,90	24,45
RGT= 32/90	0	32	1350,0	4611	1161,9	1,77	6,06	1,53	761,4	3,54	37,70
liquid temp	5	41	1643,1	5611	1414,0	1,97	6,72	1,69	834,9	3,88	46,17
Tliq= 55/131	10	50	1982,3	6770	1706,0	2,18	7,43	1,87	910,8	4,23	56,12