

Model

Designation	SC21CL	220-240V/50Hz 1~	Sales code:	104L2329
-------------	---------------	------------------	-------------	-----------------

Compressor design

Oil type	Polyolester	Refrigerant(s)	R404A, R507
Oil viscosity	32,5cST	Displacement	20,95cm ³ / 1,28cu.in
Oil quantity	544cm ³ / 18,4fl.oz	Compressors on pallet	80
Refr. charge - tech. limit	1300g / 45,9oz		
Free gas volume comp.	1410cm ³ / 47,7fl.oz		
Weight	14,1kg / 31,1lbs		
Motor protection	1# internal		
Winding resistance main	3,4Ω (at 25°C)		
Winding resistance aux	14,4Ω (at 25°C)		
Max. winding temp.	125°C / 257°F		
Max. discharge temp.	135°C / 275°F		



General - Configurations with SC21CL

	Conf. 1
Motorconfiguration	CSCR
Power supply (nominal)	220-240V/50Hz
Number of phases	1
Voltage range	198-254V
Approvals	CCC, VDE
Starting torque	HST
Note	- / -

Applications with SC21CL

	Conf. 1
Refrigerant	R404A
Application	LBP
System cooling	fan 3m/s
Hot gas defrost	OK
Long interval pull down	OK

Electrical data - Configurations with SC21CL

	Conf. 1
Starting device type	relay
Run capacitor	10μF
Start capacitor	80μF
LRA (locked rotor amps / 4s)	23,4A
RLA (rated load amps / 1s)	4,3A
Cut in current	23,4A

Model

Designation

SC21CL

220-240V/50Hz 1~

Sales code:

104L2329

Compressor dimensions

Housing	A Height	219mm / 8,62in
	B Height	213mm / 8,39in
	C Length shell	218mm / 8,58in
	D Length w. cover	255mm / 10,04in
	E Width	151mm / 5,94in

Connectors	Suction X	Discharge Y	Process Z
Diameter [mm]	øi 9,54-9,72	øi 6,41-6,59	øi 6,41-6,59
(i:inside, o:outside) [in]	øi 0,38-0,38	øi 0,25-0,26	øi 0,25-0,26
Material	copper	copper	copper
Horizontal angle ±2°	37°	37°	143°
Vertical angle ±2°	30°	0°	150°
Position l/h/w [mm]	107/193/55	115/110/63	-107/193/55
[in]	4,2/7,6/2,2	4,5/4,3/2,5	-4,2/7,6/2,2
Straight tube l. [mm]	12	12	12
[in]	0,5	0,5	0,5

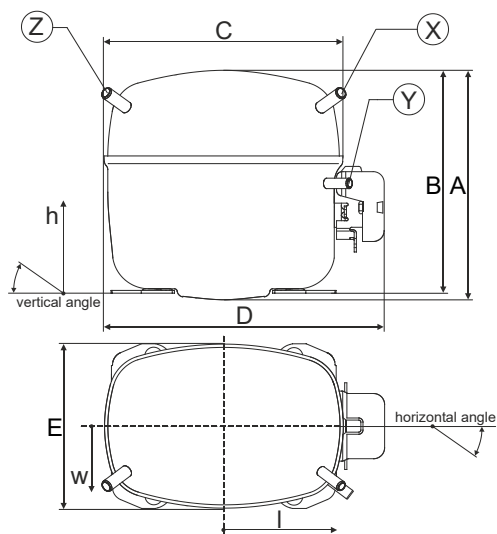

Compressor fixation



Bolt joint

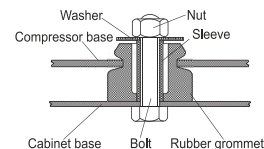

Snap-on

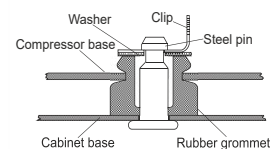

Mounting accessories

	one comp.	multi pack
Bolt joint M6 ø16mm	118-1917	118-1918
Bolt joint ø1/4" ø16mm	118-1946	
Bolt joint ø1/4" ø19mm	118-1949	
Snap-on ø7,3 ø16mm	118-1947	118-1919

Application notes

Provision for PE Grounding is located at the PE Stamp on the compressor

Model

Designation	SC21CL	220-240V/50Hz	Conf. 1	Sales code:	104L2329
-------------	---------------	----------------------	----------------	-------------	-----------------

Configuration

Motorconfiguration	CSCR
Power supply (nominal)	220-240V/50Hz 1~
Refrigerant	R404A
Application	LBP
Voltage range	198-254V
Starting torque	HST
Approvals	CCC VDE

Electrical accessories / wiring diagram

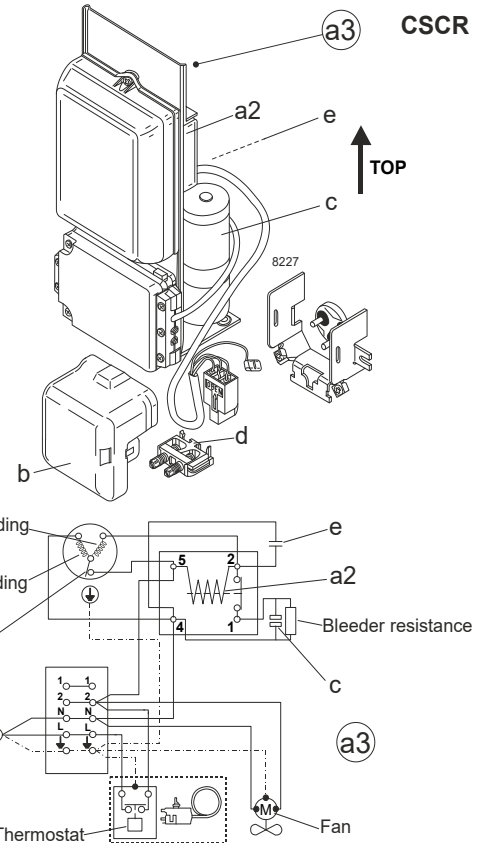

Ambient/ machine room temperatures minimum /maximum

Ambient temperature range:	10 - 38°C / 50 - 101°F
Machine room temperature range:	10 - 43°C / 50 - 110°F
Compressor cooling:	fan 3m/s

Operation Limits

Operation pressure range

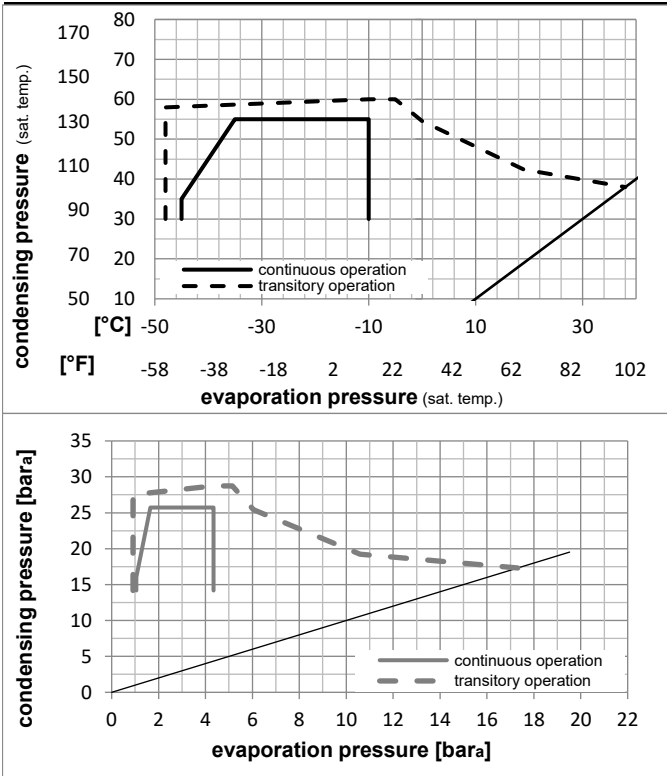

Components

a3	SC starter kit (550mm)	117-7027
b	plastic cover	103N2009
d	cord relief	103N1004

Alternative components

a3	SC starter kit (1000mm)	117-7040
a3	SC starter kit (650mm)	117-7046
c	start capacitor (80µF)	117U5373
e	run capacitor (10µF, 6.3mm)	117-7112

Model

Designation	SC21CL	220-240V/50Hz	Conf. 1	Sales code:	104L2329
-------------	---------------	----------------------	---------	-------------	-----------------

Optimization + standard conditions

R404A, 220V/50Hz, CSCR, fan 3m/s, CCC, VDE

		Evaporating pressure (saturation temperature)				Condensing pressure (saturation temperature)			Return gas temp.			Liquid temp.		Cooling capacity			COP	EER	Power consumption			ASHRAE LBP
		pe	pc	RGT	Tliq	[W]	[Btu/h]	[kcal/h]	[W/W]	[Btu/Wh]	[kcal/Wh]	P1	I	Current consumption		Ref. mass flow						
[°C]	[°F]	[°C]	[°F]	[°C]	[°F]							[W]	[A]	[A]	[kg/h]							
-23	54	32	32	902,9	3084	777,1	1,18	4,02	1,01	767,3	4,02	21,04	ASHRAE LBP									
-10	130	90	90																			
-25	55	32	55	608,5	2078	523,6	0,83	2,82	0,71	735,9	3,86	19,02	cecomaf LBP									
-13	131	90	131																			
-35	40	20	40	509,0	1738	438,1	0,98	3,34	0,84	521,1	2,95	13,83	EN12900 LBP									
-31	104	68	104																			
-23	49	4,4	49	685,6	2341	590,0	0,91	3,12	0,79	749,7	3,91	24,27	ARI540 LBP									
-10	120	40	120																			
-23	41	32	32	1091,0	3726	938,9	1,53	5,23	1,32	711,9	3,80	25,42	AHAM LBP									
-10	105	90	90																			
-35	45	32	45	455,0	1554	391,6	0,85	2,91	0,73	534,2	2,94	12,16	opt									
-31	113	90	113																			

Performance tables

R404A, 220V/50Hz, CSCR, fan 3m/s, CCC, VDE

	pe		Cooling capacity			COP	EER	P1	I	m	
	[°C]	[°F]	[W]	[Btu/h]	[kcal/h]	[W/W]	[Btu/Wh]	[kcal/Wh]	[W]	[A]	[kg/h]
[°C / °F]	-45	-49	225,9	772	194,4	0,57	1,93	0,49	399,6	2,40	6,00
cond. pressure	-35	-31	455,0	1554	391,6	0,85	2,91	0,73	534,2	2,94	12,16
pc= 45/113	-30	-22	617,4	2108	531,3	1,00	3,43	0,86	614,8	3,31	16,57
return gas temp.	-25	-13	812,8	2776	699,5	1,16	3,95	1,00	702,1	3,71	21,92
RGT= 32/90	-20	-4	1042,1	3559	896,9	1,31	4,48	1,13	794,7	4,14	28,27
liquid temp	-15	5	1306,3	4461	1124,2	1,47	5,01	1,26	890,8	4,58	35,68
Tliq= 45/113	-10	14	1606,3	5486	1382,4	1,62	5,55	1,40	989,0	5,00	44,23
[°C / °F]	-45	-49	174,5	596	150,1	0,44	1,49	0,37	401,0	2,29	5,36
cond. pressure	-35	-31	327,7	1119	282,0	0,59	2,02	0,51	553,1	2,94	10,14
pc= 55/131	-30	-22	451,7	1543	388,7	0,70	2,40	0,61	641,4	3,38	14,04
return gas temp	-25	-13	608,5	2078	523,6	0,83	2,82	0,71	735,9	3,86	19,02
RGT= 32/90	-20	-4	798,9	2728	687,5	0,96	3,27	0,82	834,8	4,37	25,14
liquid temp	-15	5	1023,9	3497	881,2	1,09	3,73	0,94	936,7	4,89	32,47
Tliq= 55/131	-10	14	1284,4	4386	1105,4	1,23	4,22	1,06	1040,1	5,41	41,12