

Model

Designation	SC21G	220-240V/50Hz 1~ 220-240V/60Hz 1~	Sales code:	104G8124
-------------	--------------	-----------------------------------	-------------	-----------------

Compressor design

Oil type	Polyolester	Refrigerant(s)	R134a
Oil viscosity	22cST	Displacement	20,95cm ³ / 1,28cu.in
Oil quantity	553cm ³ / 18,7fl.oz	Compressors on pallet	80
Refr. charge - tech. limit	1300g / 45,9oz		
Free gas volume comp.	1460cm ³ / 49,4fl.oz		
Weight	13,6kg / 30lbs		
Motor protection	1# internal		
Winding resistance main	3,5Ω (at 25°C)		
Winding resistance aux	13Ω (at 25°C)		
Max. winding temp.	125°C / 257°F		
Max. discharge temp.	130°C / 266°F		



General - Configurations with SC21G

	Conf. 1	Conf. 2
Motorconfiguration	CSCR	CSCR
Power supply (nominal)	220-240V/50Hz	220-240V/60Hz
Number of phases	1	1
Voltage range	187-254V	198-254V
Approvals	VDE, CCC, EAC	VDE, CCC, EAC
Starting torque	HST	HST
Note	- / -	

Applications with SC21G

	Conf. 1	Conf. 2
Refrigerant	R134a	R134a
Application	LBP+MBP+HBP	LBP
System cooling	fan 3m/s	fan 3m/s
Hot gas defrost	OK	OK
Long interval pull down	OK	OK

Electrical data - Configurations with SC21G

	Conf. 1	Conf. 2
Starting device type	relay	relay
Run capacitor	10μF	10μF
Start capacitor	80μF	80μF
LRA (locked rotor amps / 4s/ U(N))	22A	22A
RLA (rated load amps / 1s/ U(N))	3,9A	3,9A
Cut in current (U(N))	22A	22A

Model

Designation

SC21G

220-240V/50Hz 1~ 220-240V/60Hz 1~

Sales code:

104G8124

Compressor dimensions

Housing	A Height	219mm / 8,62in
	B Height	213mm / 8,39in
	C Length shell	218mm / 8,58in
	D Length w. cover	255mm / 10,04in
	E Width	151mm / 5,94in

Connectors	Suction		Discharge		Process	
	X	Y	Z	X	Y	Z
Diameter [mm]	øi 10,11-10,29	øi 6,41-6,59	øi 6,41-6,59	øi 10,11-10,29	øi 6,41-6,59	øi 6,41-6,59
(i:inside, o:outside) [in]	øi 0,4-0,41	øi 0,25-0,26	øi 0,25-0,26	øi 0,4-0,41	øi 0,25-0,26	øi 0,25-0,26
Material	copper	copper	copper	copper	copper	copper
Horizontal angle ±2°	37°	37°	143°	37°	37°	143°
Vertical angle ±2°	30°	0°	150°	30°	0°	150°
Position l/h/w [mm]	107/193/55	115/110/63	-107/193/55	107/193/55	115/110/63	-107/193/55
[in]	4,2/7,6/2,2	4,5/4,3/2,5	-4,2/7,6/2,2	4,2/7,6/2,2	4,5/4,3/2,5	-4,2/7,6/2,2
Straight tube l. [mm]	12	12	12	12	12	12
[in]	0,5	0,5	0,5	0,5	0,5	0,5

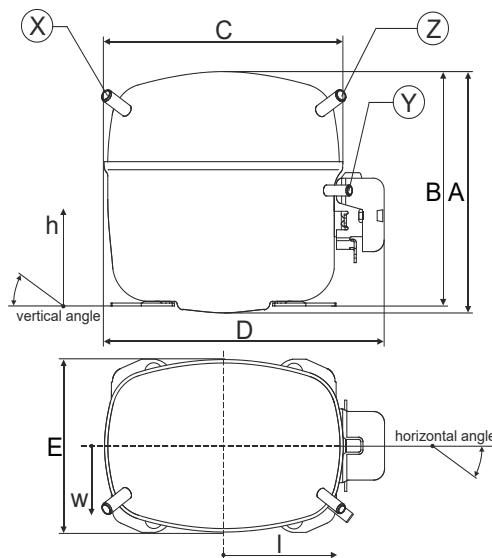

Compressor fixation

Baseplate	[mm]	[inch]
BI	204	8.03
Bw	150	5.9
øE	ø 9.7	ø 0.38

Large holes	[mm]	[inch]
LI	165	6.5
Lw	101.6	4
øL	ø 19	ø 0.75

Small holes	[mm]	[inch]
SI	170	6.7
Sw	70	2.76
øS	ø 16	ø 0.63
QI	127	5
Qw	127	5

Bolt joint

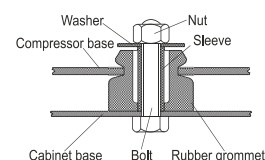

Snap-on

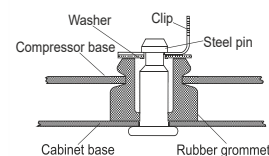

Mounting accessories

Mounting accessories	one comp.	multi pack
Bolt joint M6 ø16mm	118-1917	118-1918
Bolt joint ø1/4" ø16mm	118-1946	
Bolt joint ø1/4" ø19mm	118-1949	
Snap-on ø7,3 ø16mm	118-1947	118-1919

Application notes

Provision for PE Grounding is located at the PE Stamp on the compressor

Model

Designation	SC21G	220-240V/50Hz	Conf. 1	Sales code:	104G8124
-------------	--------------	----------------------	----------------	-------------	-----------------

Configuration

Motorconfiguration	CSCR
Power supply (nominal)	220-240V/50Hz 1~
Refrigerant	R134a
Application	LBP+MBP+HBP
Voltage range	187-254V
Starting torque	HST
Approvals	VDE
	CCC
	EAC

Electrical accessories / wiring diagram

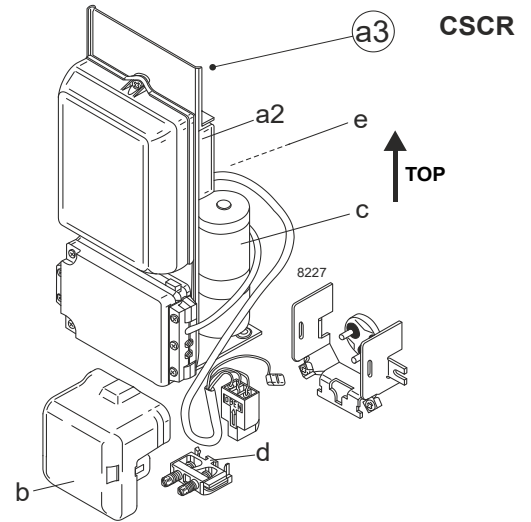

Ambient/ machine room temperatures minimum /maximum

Ambient temperature range:	10 - 43°C / 50 - 110°F
Machine room temperature range:	10 - 48°C / 50 - 119°F
Compressor cooling:	fan 3m/s

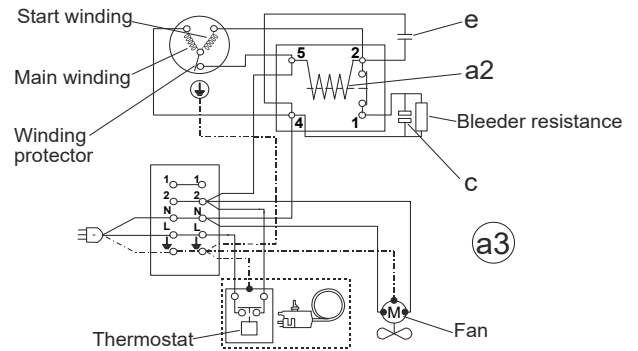

Operation pressure range

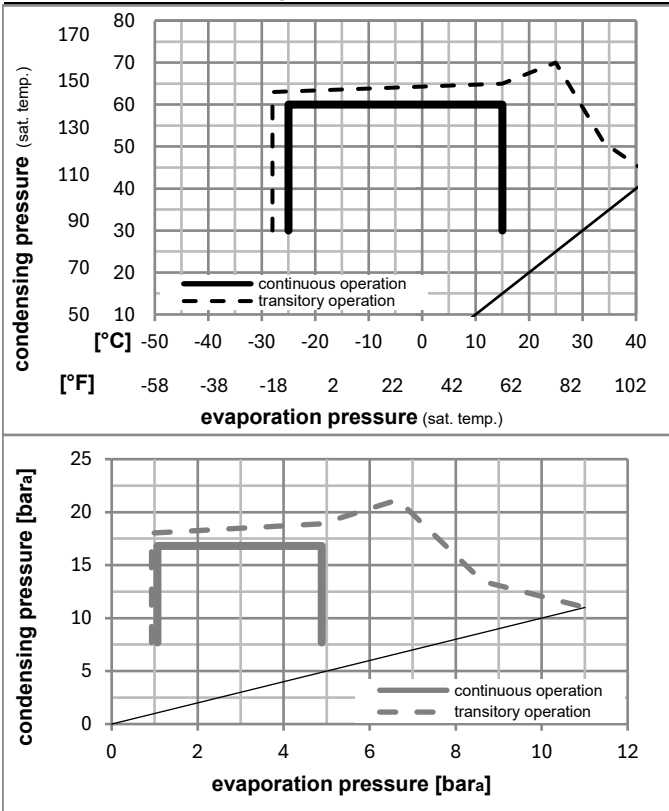

Components

a3	SC starter kit (550mm)	117-7029
b	plastic cover	103N2009
d	cord relief	103N1004

Alternative components

a3	SC starter kit (650mm)	117-7032
a3	SC starter kit (1000mm)	117-7041
a2	potential relay (RVA 4H3R341)	117-7427
c	start capacitor (80µF)	117U5373
e	run capacitor (10µF, 6.3mm)	117-7112

Model

Designation **SC21G** **220-240V/50Hz** Conf. 1 Sales code: **104G8124**

Optimization + standard conditions

R134a, 220V/50Hz, CSCR, fan 3m/s, VDE, CCC, EAC

	Evaporating pressure (saturation temperature)				Condensing pressure (saturation temperature)			Return gas temp.	Liquid temp.	Cooling capacity	COP	EER	Power consumption			
	pe	pc	RGT	Tliq	[W]	[Btu/h]	[kcal/h]						P1	I	Ref. mass flow	
	[°C]	[°F]	[°C]	[°F]	[W]	[Btu/h]	[kcal/h]	[W/W]	[Btu/Wh]	[kcal/Wh]	[W]	[A]	[kg/h]			
ASHRAE LBP	-23	54	32	32	460,1	1571	396,0	1,22	4,18	1,05	375,7	2,34	8,93			
cecomaf LBP	-25	55	32	55	332,7	1136	286,4	0,96	3,26	0,82	348,2	2,28	7,96			
EN12900 LBP	-35	40	20	40	222,2	759	191,2	0,88	2,99	0,75	253,6	1,96	4,87			
ASHRAE MBP	-7	54	35	46	1040,5	3553	895,5	1,68	5,75	1,45	617,9	3,14	22,70			
cecomaf MBP	-10	55	32	55	792,6	2707	682,1	1,39	4,75	1,20	569,4	2,96	19,16			
EN12900 MBP	-10	45	20	45	931,8	3182	801,9	1,63	5,58	1,41	570,2	2,87	21,81			

Performance tables

R134a, 220V/50Hz, CSCR, fan 3m/s, VDE, CCC, EAC

	pe		Cooling capacity			COP	EER	P1	I	m	
	[°C]	[°F]	[W]	[Btu/h]	[kcal/h]	[W/W]	[Btu/Wh]	[kcal/Wh]	[W]	[A]	[kg/h]
[°C / °F]	-25	-13	420,9	1438	362,3	1,11	3,80	0,96	378,0	2,26	9,12
cond. pressure	-20	-4	570,4	1948	490,9	1,29	4,40	1,11	442,9	2,44	12,39
pc= 45/113	-10	14	966,8	3302	832,0	1,70	5,79	1,46	570,2	2,87	21,16
return gas temp.	-5	23	1215,3	4150	1045,9	1,93	6,60	1,66	629,0	3,12	26,72
RGT= 32/90	0	32	1498,4	5117	1289,5	2,20	7,50	1,89	682,2	3,39	33,14
liquid temp	5	41	1816,9	6205	1563,6	2,50	8,52	2,15	727,9	3,68	40,45
Tliq= 45/113	15	59	2563,1	8754	2205,8	3,25	11,08	2,79	789,8	4,34	58,06
[°C / °F]	-25	-13	332,7	1136	286,4	0,96	3,26	0,82	348,2	2,28	7,96
cond. pressure	-20	-4	453,1	1547	389,9	1,07	3,67	0,92	421,7	2,48	10,87
pc= 55/131	-10	14	792,6	2707	682,1	1,39	4,75	1,20	569,4	2,96	19,16
return gas temp	-5	23	1013,3	3461	872,0	1,58	5,41	1,36	640,0	3,24	24,63
RGT= 32/90	0	32	1269,0	4334	1092,1	1,80	6,14	1,55	705,9	3,54	31,04
liquid temp	5	41	1560,5	5329	1343,0	2,04	6,96	1,75	765,4	3,87	38,45
Tliq= 55/131	15	59	2254,0	7698	1939,8	2,63	8,97	2,26	858,1	4,60	56,61

Model

Designation	SC21G	220-240V/60Hz	Conf. 2	Sales code:	104G8124
-------------	--------------	----------------------	----------------	-------------	-----------------

Configuration

Motorconfiguration	CSCR
Power supply (nominal)	220-240V/60Hz 1~
Refrigerant	R134a
Application	LBP
Voltage range	198-254V
Starting torque	HST
Approvals	VDE
	CCC
	EAC

Electrical accessories / wiring diagram

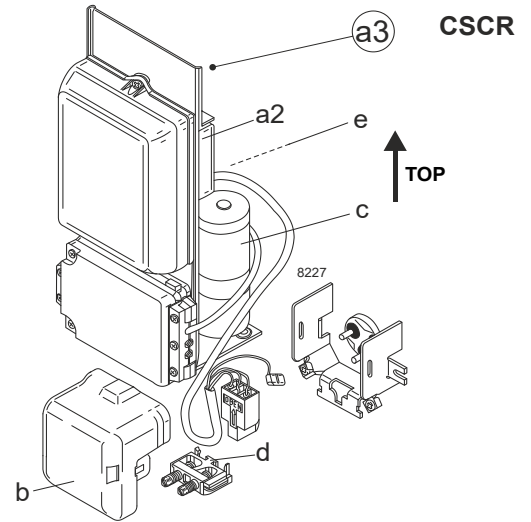

Ambient/ machine room temperatures minimum /maximum

Ambient temperature range:	10 - 43°C / 50 - 110°F
Machine room temperature range:	10 - 48°C / 50 - 119°F
Compressor cooling:	fan 3m/s

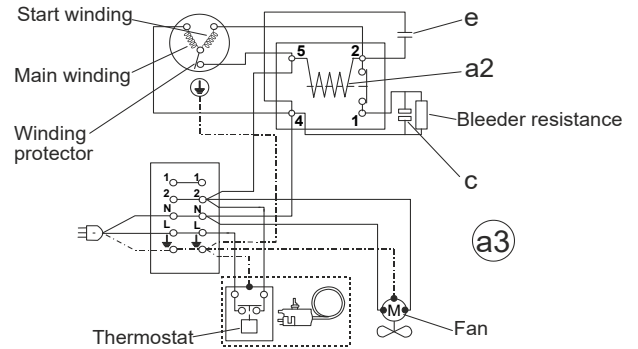

Operation pressure range

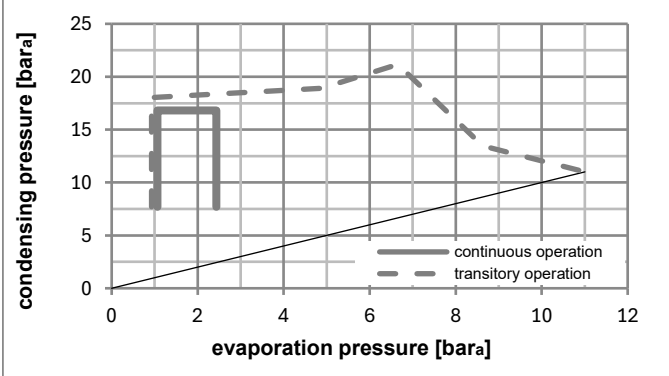
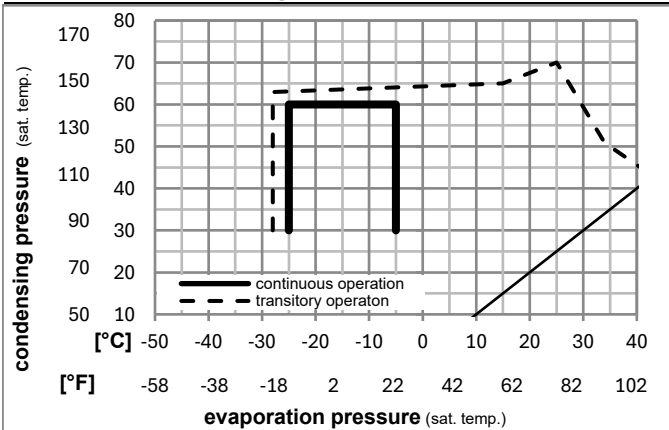

Components

a3	SC starter kit (550mm)	117-7029
b	plastic cover	103N2009
d	cord relief	103N1004

Alternative components

a3	SC starter kit (650mm)	117-7032
a3	SC starter kit (1000mm)	117-7041
a2	potential relay (RVA 4H3R341)	117-7427
c	start capacitor (80µF)	117U5373
e	run capacitor (10µF, 6.3mm)	117-7112

Model

Designation **SC21G** **220-240V/60Hz** Conf. 2 Sales code: **104G8124**

Optimization + standard conditions

R134a, 230V/60Hz, CSCR, fan 3m/s, VDE, CCC, EAC

	Evaporating pressure (saturation temperature)				Cooling capacity			COP	EER	P1	Power consumption		ASHRAE LBP	
	pe	pc	RGT	Tliq	[W]	[Btu/h]	[kcal/h]				I	m		
	[°C]	[°F]	[°C]	[°F]	[W]	[Btu/h]	[kcal/h]	[W/W]	[Btu/Wh]	[kcal/Wh]	[W]	[A]	[kg/h]	
	-23	54	32	32	443,9	1516	382,0	1,07	3,67	0,92	413,2	1,90	8,62	ASHRAE LBP
	-10	130	90	90										
	-25	55	32	55	303,4	1036	261,1	0,80	2,74	0,69	378,6	1,77	7,25	cecomaf LBP
	-13	131	90	131										
	-35	40	20	40	231,4	790	199,1	0,82	2,79	0,70	283,4	1,29	5,08	EN12900 LBP
	-31	104	68	104										
	-7	54	35	46	1165,8	3981	1003,3	1,67	5,69	1,43	700,0	3,09	25,43	ASHRAE MBP
	20	130	95	115										
	-10	55	32	55	880,1	3006	757,4	1,36	4,66	1,17	645,1	2,86	21,28	cecomaf MBP
	14	131	90	131										
	-10	45	20	45	1000,0	3415	860,6	1,61	5,49	1,38	622,6	2,73	23,41	EN12900 MBP
	14	113	68	113										

Performance tables

R134a, 230V/60Hz, CSCR, fan 3m/s, VDE, CCC, EAC

	pe		Cooling capacity			COP	EER	P1	I	m	
	[°C]	[°F]	[W]	[Btu/h]	[kcal/h]						
[°C / °F]	-25	-13	439,8	1502	378,5	1,07	3,64	0,92	412,9	1,84	9,53
cond. pressure	-23	-10	493,1	1684	424,3	1,13	3,85	0,97	437,2	1,94	10,69
pc= 45/113	-20	-4	606,1	2070	521,6	1,25	4,28	1,08	483,6	2,15	13,17
return gas temp.	-18	0	688,9	2353	592,9	1,34	4,58	1,15	514,2	2,28	14,99
RGT= 32/90	-15	5	803,8	2745	691,7	1,45	4,96	1,25	553,0	2,44	17,52
liquid temp	-10	14	1037,5	3543	892,9	1,67	5,69	1,43	622,6	2,73	22,71
Tliq= 45/113	-5	23	1311,7	4480	1128,9	1,89	6,46	1,63	693,8	3,01	28,84
[°C / °F]	-25	-13	303,4	1036	261,1	0,80	2,74	0,69	378,6	1,77	7,25
cond. pressure	-23	-10	354,9	1212	305,4	0,86	2,95	0,74	410,9	1,90	8,49
pc= 55/131	-20	-4	464,0	1585	399,3	0,98	3,36	0,85	471,7	2,14	11,13
return gas temp	-18	0	543,9	1858	468,1	1,06	3,63	0,92	511,1	2,30	13,07
RGT= 32/90	-15	5	654,7	2236	563,4	1,17	3,99	1,01	560,1	2,51	15,76
liquid temp	-10	14	880,1	3006	757,4	1,36	4,66	1,17	645,1	2,86	21,28
Tliq= 55/131	-5	23	1144,6	3909	985,1	1,57	5,37	1,35	728,2	3,21	27,82