

Model

Designation	SCE18MNX	220-240V/50Hz 1~	Sales code:	104H8849
-------------	-----------------	-------------------------	-------------	-----------------

Compressor design

Oil type	Polyolester	Refrigerant(s)	R290
Oil viscosity	32cST	Displacement	17,69cm ³ / 1,08cu.in
Oil quantity	550cm ³ / 18,6fl.oz	Compressors on pallet	80
Refr. charge - tech. limit	550g / 19,4oz		
Free gas volume comp.	1460cm ³ / 49,4fl.oz		
Weight	14,2kg / 31,3lbs		
Motor protection	external		
Winding resistance main	3,44Ω (at 25°C)		
Winding resistance aux	9,4Ω (at 25°C)		
Max. winding temp.	125°C / 257°F		
Max. discharge temp.	135°C / 275°F		



General - Configurations with SCE18MNX

	Conf. 1	Conf. 2
Motorconfiguration	CSIR	CSIR
Power supply (nominal)	220-240V/50Hz	220-240V/50Hz
Number of phases	1	1
Voltage range	198-254V	198-254V
Approvals	VDE, CCC, EAC, CB	VDE, CCC, EAC, CB
Starting torque	HST	HST
Note	Electrical equipment is included and pre-assembled to compressor.	

Applications with SCE18MNX

	Conf. 1	Conf. 2
Refrigerant	R290	R290
Application	MBP	MBP
System cooling	fan 3m/s	fan 3m/s
Hot gas defrost	OK	OK
Long interval pull down	OK	OK

Electrical data - Configurations with SCE18MNX

	Conf. 1	Conf. 2
Starting device type	relay	relay
Run capacitor	-/-	-/-
Start capacitor	80μF	80μF
LRA (locked rotor amps / 4s)	21,07A	21,07A
RLA (rated load amps / 1s)	3,75A	3,75A
Cut in current	21,07A	21,07A

Model

Designation	SCE18MNX	220-240V/50Hz 1~	Sales code:	104H8849
-------------	-----------------	------------------	-------------	-----------------

Compressor dimensions

Housing	A Height	219mm / 8,62in
	B Height	213mm / 8,39in
	C Length shell	218mm / 8,58in
	D Length w. cover	255mm / 10,04in
	E Width	151mm / 5,94in

Connectors		Suction	Discharge	Process
		X	Y	Z
Diameter	[mm]	øi 10,11-10,29	øi 6,11-6,29	øi 6,11-6,29
	(i:inside, o:outside) [in]	øi 0,4-0,41	øi 0,24-0,25	øi 0,24-0,25
Material		copper	copper	copper
Horizontal angle	±2°	37°	37°	143°
Vertical angle	±2°	30°	0°	150°
Position l/h/w	[mm]	107/193/55	115/110/63	-107/193/55
	[in]	4,2/7,6/2,2	4,5/4,3/2,5	-4,2/7,6/2,2
Straight tube l.	[mm]	12	12	12
	[in]	0,5	0,5	0,5

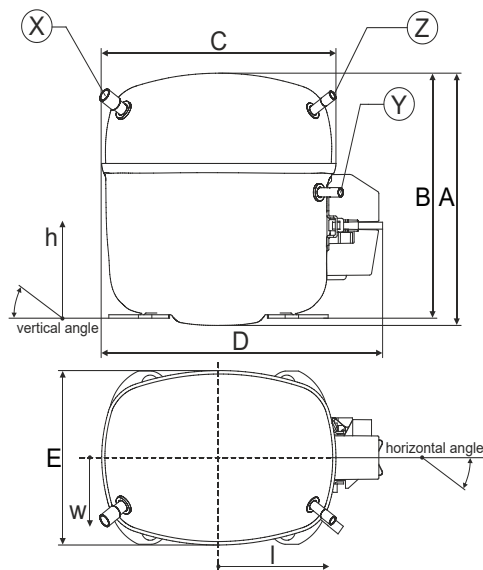

Compressor fixation

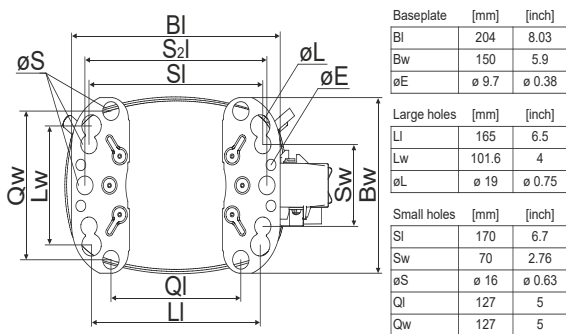

Bolt joint

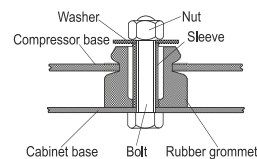

Snap-on

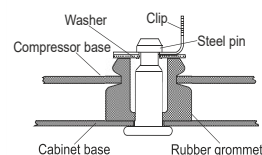

Mounting accessories	one comp.	multi pack
Bolt joint M6 ø16mm	118-1917	118-1918
Bolt joint ø1/4" ø16mm	118-1946	
Bolt joint ø1/4" ø19mm	118-1949	
Snap-on ø7,3 ø16mm	118-1947	118-1919

Application notes

Provision for PE Grounding is located at the PE Stamp on the compressor

Model

Designation **SCE18MNX** **220-240V/50Hz** Conf. 1 Sales code: **104H8849**

Configuration

Motorconfiguration CSIR
 Power supply (nominal) 220-240V/50Hz 1~
 Refrigerant R290
 Application MBP
 Voltage range 198-254V
 Starting torque HST
 Approvals VDE
 CCC
 EAC
 CB

Electrical accessories / wiring diagram

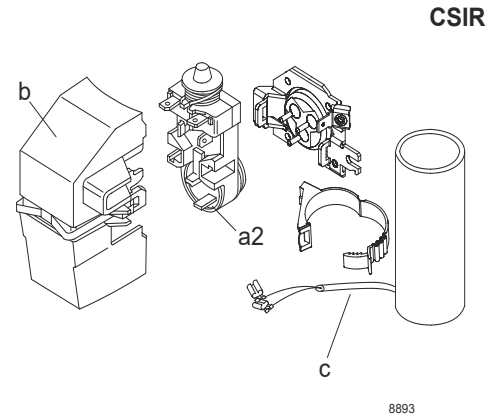

Ambient/ machine room temperatures minimum /maximum

Ambient temperature range: 10 - 38°C / 50 - 101°F

Machine room temperature range: 10 - 43°C / 50 - 110°F

Compressor cooling: fan 3m/s

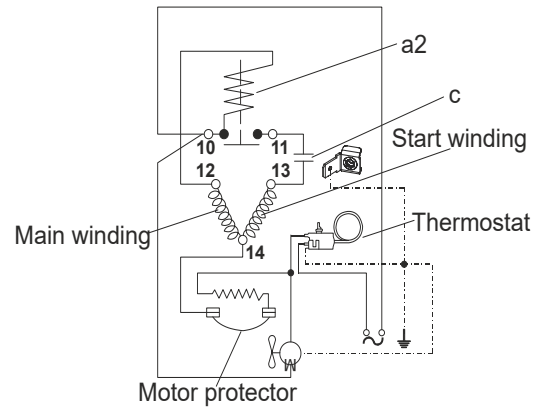

Operation pressure range

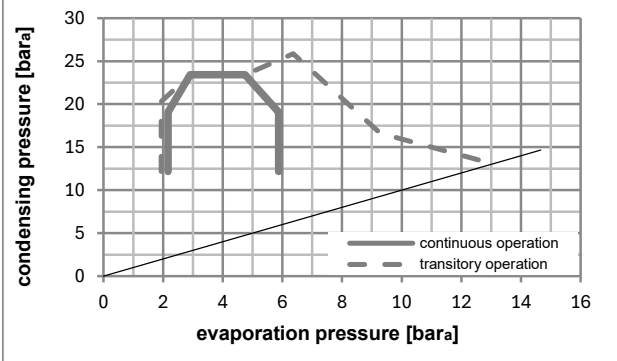
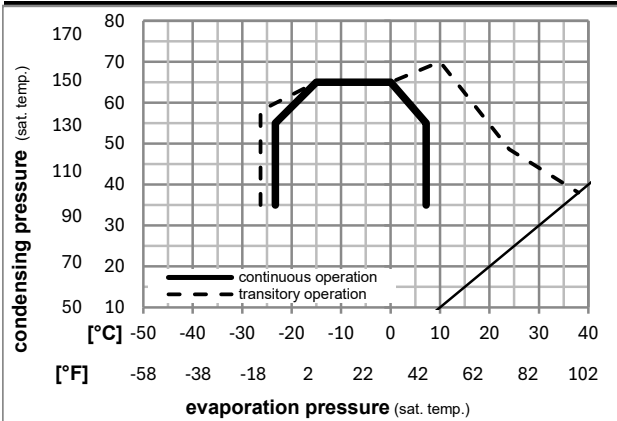

Components (already pre-assembled, cord relief not inclu.)

a2	assy. relay + ext. protector (T0214)	117U7406
c	start capacitor (80µF)	117U5017
d	cord relief	103N1004
b	plastic cover + clamp	117U1033

Noise emission

Operation pressures:	pe: -10°C / 14°F
	pc: 45°C / 113°F
Motor speed appr.:	2900rpm
Lw(A):	58dB(A)

Model

Designation **SCE18MNX** **220-240V/50Hz** Conf. 1 Sales code: **104H8849**

Optimization + standard conditions

R290, 230V/50Hz, CSIR, fan 3m/s, VDE, CCC, EAC, CB

Evaporating pressure (saturation temperature)					Condensing pressure (saturation temperature)						Power consumption			ASHRAE MBP
Return gas temp.					Liquid temp.						Current consumption		Ref. mass flow	
pe	pc	RGT	Tliq	[W]	[Btu/h]	[kcal/h]	COP	EER	[kcal/Wh]	P1	I	m		
[°C]	[°C]	[°C]	[°C]	[W]	[Btu/h]	[kcal/h]	[W/W]	[Btu/Wh]	[kcal/Wh]	[W]	[A]	[kg/h]		
-7	54	35	46	1503,3	5134	1293,8	1,98	6,75	1,70	761,1	4,43	17,15	ASHRAE MBP	
[°F]	[°F]	[°F]	[°F]											
20	130	95	115											
-10	55	32	55	1189,8	4063	1023,9	1,64	5,61	1,41	723,7	4,30	15,05	cecomaf MBP	
[°F]	[°F]	[°F]	[°F]											
14	131	90	131											
-10	45	20	45	1320,5	4510	1136,5	1,98	6,78	1,71	665,4	4,11	16,21	EN12900 MBP	
[°F]	[°F]	[°F]	[°F]											
14	113	68	113											
-7	49	18	49	1410,0	4816	1213,5	1,95	6,65	1,68	724,1	4,31	18,31	ARI540 MBP	
[°F]	[°F]	[°F]	[°F]											
20	120	65	120											
-10	45	32	45	1374,7	4695	1183,1	2,07	7,06	1,78	665,4	4,11	15,73	opt	
[°F]	[°F]	[°F]	[°F]											
14	113	90	113											
-25	45	32	45	719,1	2456	618,9	1,39	4,76	1,20	515,9	3,68	8,11	opt	
[°F]	[°F]	[°F]	[°F]											
-13	113	90	113											

Performance tables

R290, 230V/50Hz, CSIR, fan 3m/s, VDE, CCC, EAC, CB

	pe		Cooling capacity			COP	EER	P1	I	m	
	[°C]	[°F]	[W]	[Btu/h]	[kcal/h]	[W/W]	[Btu/Wh]	[kcal/Wh]	[W]	[A]	[kg/h]
[°C / °F]	-23	-10	777,3	2655	668,9	1,46	4,99	1,26	531,8	3,71	8,78
cond. pressure	-20	-4	901,8	3080	776,1	1,60	5,46	1,38	564,4	3,80	10,21
pc= 45/113	-15	5	1120,1	3825	964,0	1,82	6,21	1,57	615,5	3,95	12,74
return gas temp.	-10	14	1374,7	4695	1183,1	2,07	7,06	1,78	665,4	4,11	15,73
RGT= 32/90	-5	23	1666,3	5691	1434,0	2,35	8,01	2,02	710,1	4,27	19,19
liquid temp	0	32	1995,5	6815	1717,4	2,68	9,14	2,30	745,6	4,39	23,15
Tliq= 45/113	7,2	45	2537,0	8664	2183,3	3,28	11,21	2,83	772,7	4,48	29,81
[°C / °F]	-23	-10	653,8	2233	562,7	1,17	4,01	1,01	557,0	3,78	8,15
cond. pressure	-20	-4	768,2	2623	661,1	1,29	4,40	1,11	596,5	3,89	9,61
pc= 55/131	-15	5	964,7	3295	830,2	1,46	4,99	1,26	659,8	4,09	12,13
return gas temp.	-10	14	1189,8	4063	1023,9	1,64	5,61	1,41	723,7	4,30	15,05
RGT= 32/90	-5	23	1444,1	4932	1242,8	1,84	6,29	1,59	784,0	4,51	18,40
liquid temp	0	32	1728,3	5902	1487,4	2,06	7,05	1,78	837,0	4,70	22,20
Tliq= 55/131	7,2	45	2191,4	7484	1885,9	2,46	8,39	2,11	892,4	4,90	28,55

Model

Designation	SCE18MNX	220-240V/50Hz	Conf. 2	Sales code:	104H8849
-------------	-----------------	----------------------	---------	-------------	-----------------

Configuration

Motorconfiguration	CSIR
Power supply (nominal)	220-240V/50Hz 1~
Refrigerant	R290
Application	MBP
Voltage range	198-254V
Starting torque	HST
Approvals	VDE
	CCC
	EAC
	CB

Electrical accessories / wiring diagram

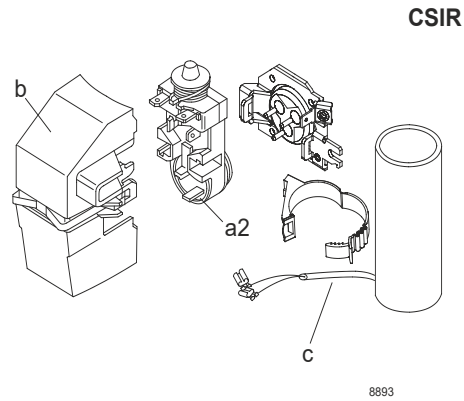

Ambient/ machine room temperatures minimum /maximum

Ambient temperature range:	10 - 43°C / 50 - 110°F
Machine room temperature range:	10 - 48°C / 50 - 119°F
Compressor cooling:	fan 3m/s

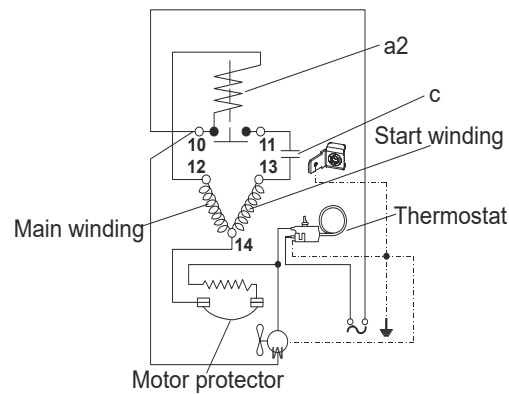

Operation pressure range

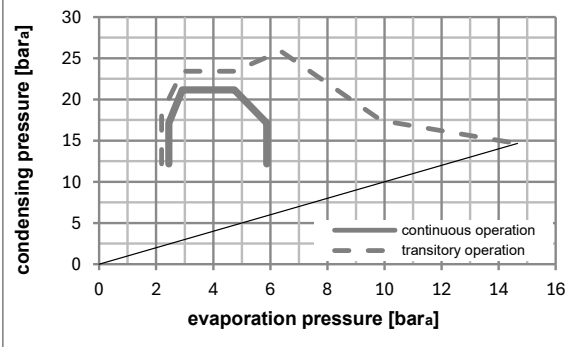
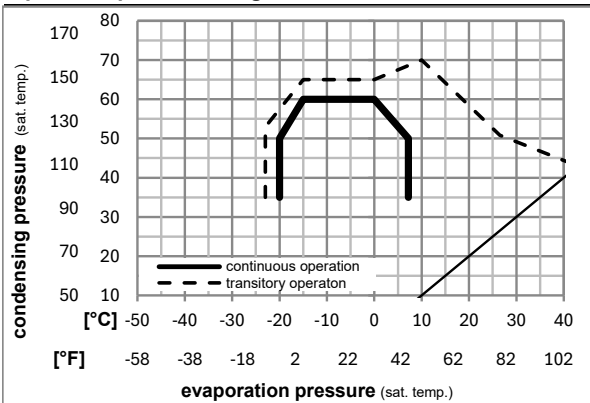

Components (already pre-assembled, cord relief not inclu.)

a2	assy. relay + ext. protector (T0214)	117U7406
c	start capacitor (80µF)	117U5017
d	cord relief	103N1004
b	plastic cover + clamp	117U1033

Noise emission

Operation pressures:	pe: -10°C / 14°F
	pc: 45°C / 113°F
Motor speed appr.:	2900rpm
Lw(A):	58dB(A)

Model

Designation **SCE18MNX** **220-240V/50Hz** Conf. 2 Sales code: **104H8849**

Optimization + standard conditions

R290, 230V/50Hz, CSIR, fan 3m/s, VDE, CCC, EAC, CB

Evaporating pressure (saturation temperature)					Condensing pressure (saturation temperature)						Power consumption			ASHRAE MBP
Return gas temp.				Cooling capacity	COP	EER	P1	Current consumption		Ref. mass flow				
Liquid temp.		I	m											
pe	pc							RGT	Tliq		[W]	[A]	[kg/h]	
[°C]	[°F]	[W]	[Btu/h]	[kcal/h]	[W/W]	[Btu/Wh]	[kcal/Wh]	[W]	[A]	[kg/h]				
-7	54	35	46	1503,3	1,98	6,75	1,70	761,1	4,43	17,15	ASHRAE MBP			
20	130	95	115											
-10	55	32	55	1189,8	1,64	5,61	1,41	723,7	4,30	15,05	cecomaf MBP			
14	131	90	131											
-10	45	20	45	1320,5	1,98	6,78	1,71	665,4	4,11	16,21	EN12900 MBP			
14	113	68	113											
-7	49	18	49	1410,0	1,95	6,65	1,68	724,1	4,31	18,31	ARI540 MBP			
20	120	65	120											
-10	45	32	45	1374,7	2,07	7,06	1,78	665,4	4,11	15,73	opt			
14	113	90	113											
-25	45	32	45	719,1	1,39	4,76	1,20	515,9	3,68	8,11	opt			
-13	113	90	113											

Performance tables

R290, 230V/50Hz, CSIR, fan 3m/s, VDE, CCC, EAC, CB

	pe		Cooling capacity			COP	EER		P1	I	m
	[°C]	[°F]	[W]	[Btu/h]	[kcal/h]	[W/W]	[Btu/Wh]	[kcal/Wh]	[W]	[A]	[kg/h]
[°C / °F]	-20	-4	901,8	3080	776,1	1,60	5,46	1,38	564,4	3,80	10,21
cond. pressure	-15	5	1120,1	3825	964,0	1,82	6,21	1,57	615,5	3,95	12,74
pc= 45/113	-10	14	1374,7	4695	1183,1	2,07	7,06	1,78	665,4	4,11	15,73
return gas temp.	-7	20	1563,0	5338	1345,1	2,25	7,67	1,93	695,7	4,22	17,95
RGT= 32/90	-5	23	1666,3	5691	1434,0	2,35	8,01	2,02	710,1	4,27	19,19
liquid temp	0	32	1995,5	6815	1717,4	2,68	9,14	2,30	745,6	4,39	23,15
Tliq= 45/113	7,2	45	2537,0	8664	2183,3	3,28	11,21	2,83	772,7	4,48	29,81
[°C / °F]	-20	-4	768,2	2623	661,1	1,29	4,40	1,11	596,5	3,89	9,61
cond. pressure	-15	5	964,7	3295	830,2	1,46	4,99	1,26	659,8	4,09	12,13
pc= 55/131	-10	14	1189,8	4063	1023,9	1,64	5,61	1,41	723,7	4,30	15,05
return gas temp	-7	20	1354,3	4625	1165,5	1,77	6,05	1,53	764,1	4,44	17,21
RGT= 32/90	-5	23	1444,1	4932	1242,8	1,84	6,29	1,59	784,0	4,51	18,40
liquid temp	0	32	1728,3	5902	1487,4	2,06	7,05	1,78	837,0	4,70	22,20
Tliq= 55/131	7,2	45	2191,4	7484	1885,9	2,46	8,39	2,11	892,4	4,90	28,55