

Model

Designation	SCE18MNX	208-230V/60Hz 1~	Sales code:	104H8879
-------------	-----------------	------------------	-------------	-----------------

Compressor design

Oil type	Polyolester	Refrigerant(s)	R290
Oil viscosity	32cST	Displacement	17,69cm ³ / 1,08cu.in
Oil quantity	550cm ³ / 18,6fl.oz	Compressors on pallet	80
Refr. charge - tech. limit	450g / 15,9oz		
Free gas volume comp.	1460cm ³ / 49,4fl.oz		
Weight	14,2kg / 31,3lbs		
Motor protection	external		
Winding resistance main	2,58Ω (at 25°C)		
Winding resistance aux	9,77Ω (at 25°C)		
Max. winding temp.	125°C / 257°F		
Max. discharge temp.	135°C / 275°F		



General - Configurations with SCE18MNX

Conf. 1	
Motorconfiguration	CSCR
Power supply (nominal)	208-230V/60Hz
Number of phases	1
Voltage range	187-253V
Approvals	UL
Starting torque	HST
Note	Protector and cover are included and pre-assembled to compressor.

Applications with SCE18MNX

Conf. 1	
Refrigerant	R290
Application	MBP
System cooling	fan 3m/s
Hot gas defrost	OK
Long interval pull down	OK

Electrical data - Configurations with SCE18MNX

Conf. 1	
Starting device type	relay
Run capacitor	10μF
Start capacitor	80μF
LRA (locked rotor amps / 4s/ U(N))	26,12A
RLA (rated load amps / 1s/ U(N))	4,54A
Cut in current (U(N))	26,12A

Model

Designation **SCE18MNX** 208-230V/60Hz 1~ Sales code: **104H8879**

Compressor dimensions

Housing	A Height	219mm / 8,62in
	B Height	213mm / 8,39in
	C Length shell	218mm / 8,58in
	D Length w. cover	255mm / 10,04in
	E Width	151mm / 5,94in

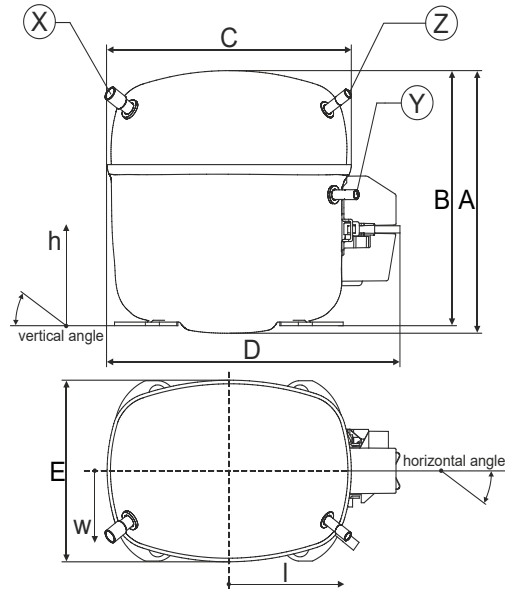

Connectors		Suction	Discharge	Process
		X	Y	Z
Diameter	[mm]	øi 9,54-9,72	øi 6,41-6,59	øi 6,41-6,59
(i:inside, o:outside)	[in]	øi 0,38-0,38	øi 0,25-0,26	øi 0,25-0,26
Material		copper	copper	copper
Horizontal angle	±2°	37°	37°	143°
Vertical angle	±2°	30°	0°	150°
Position l/h/w	[mm]	107/193/55	115/110/63	-107/193/55
	[in]	4,2/7,6/2,2	4,5/4,3/2,5	-4,2/7,6/2,2
Straight tube l.	[mm]	12	12	12
	[in]	0,5	0,5	0,5

Compressor fixation

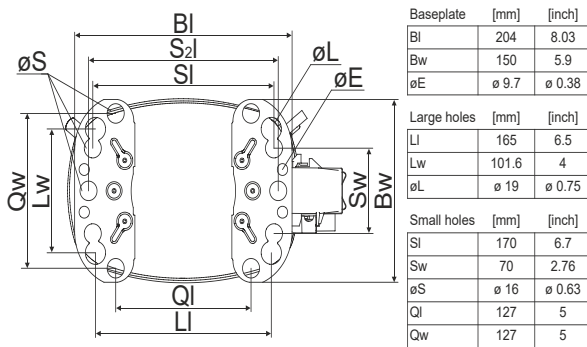

Bolt joint

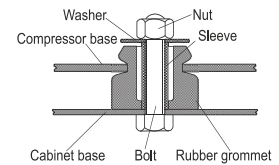

Snap-on

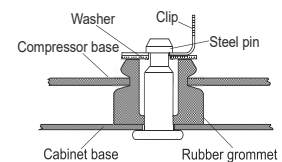

Mounting accessories	one comp.	multi pack
Bolt joint M6 ø16mm	118-1917	118-1918
Bolt joint ø1/4" ø16mm	118-1946	
Bolt joint ø1/4" ø19mm	118-1949	
Snap-on ø7,3 ø16mm	118-1947	118-1919

Application notes

Provision for PE Grounding is located at the PE Stamp on the compressor

Model

Designation **SCE18MNX** **208-230V/60Hz** Conf. 1 Sales code: **104H8879**

Configuration

Motor configuration CSCR
 Power supply (nominal) 208-230V/60Hz 1~
 Refrigerant R290
 Application MBP
 Voltage range 187-253V
 Starting torque HST
 Approvals UL

Electrical accessories / wiring diagram

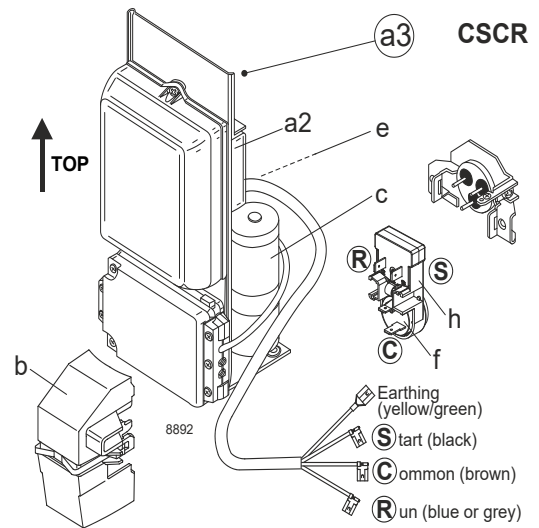

Ambient/ machine room temperatures minimum /maximum

Ambient temperature range: 10 - 43°C / 50 - 110°F

Machine room temperature range: 10 - 48°C / 50 - 119°F

Compressor cooling: fan 3m/s

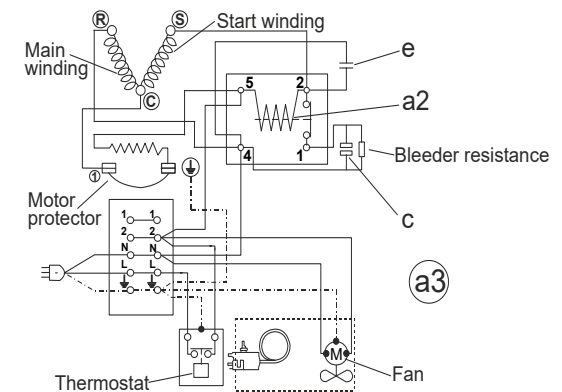

Operation pressure range

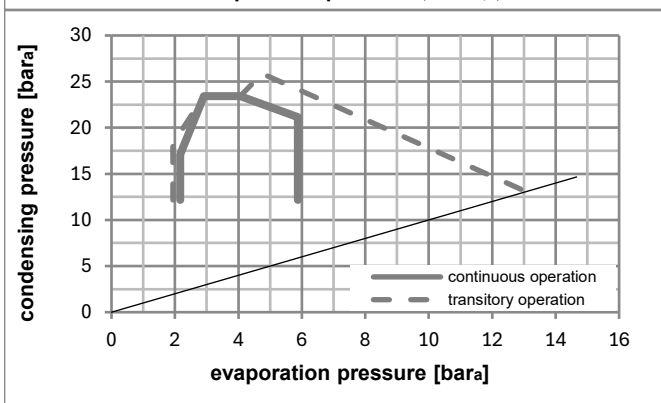
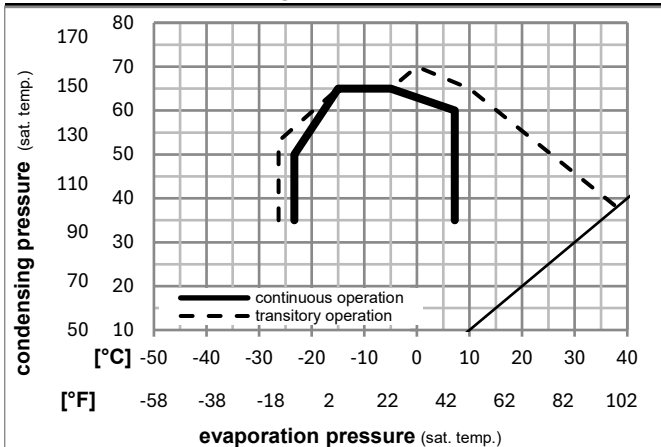

Components (protector + ~holder + cover: pre assembled)

a3	SC starter kit (550mm)	117-7807
f / h	motor protector assy. (T0715)	117U8003
b	plastic cover	117U1021

Alternative comp. (protector + ~holder + cover: pre assemb.)

a2	potential relay (RVA 2GR134)	117-7445
e	run capacitor (10µF, 6.3mm)	117-7121
c	start capacitor (80µF)	117U5373
f / h	motor protector assy. (T0715)	117U8003
b	plastic cover	117U1021

Noise emission

Operation pressures:	pe: -10°C / 14°F
	pc: 45°C / 113°F
Motor speed appr.:	3500rpm
Lw(A):	61dB(A)

Model

Designation **SCE18MNX** **208-230V/60Hz** Conf. 1 Sales code: **104H8879**

Optimization + standard conditions

R290, 230V/60Hz, CSCR, fan 3m/s, UL

Evaporating pressure (saturation temperature)					Condensing pressure (saturation temperature)			Return gas temp.			Liquid temp.			Cooling capacity			COP	EER	Power consumption			Ref. mass flow
pe	pc	RGT	Tliq		[W]	[Btu/h]	[kcal/h]	[W/W]	[Btu/Wh]	[kcal/Wh]	[W]	I	m				[A]	[kg/h]				
[°C]	-7	54	35	46	1803,7	6160	1552,3	2,21	7,53	1,90	817,6	3,97	20,58							ASHRAE MBP		
[°F]	20	130	95	115																		
[°C]	-10	55	32	55	1425,3	4868	1226,6	1,84	6,27	1,58	776,1	3,81	18,03							cecomaf MBP		
[°F]	14	131	90	131																		
[°C]	-10	45	20	45	1594,3	5445	1372,1	2,18	7,46	1,88	729,8	3,57	19,58							EN12900 MBP		
[°F]	14	113	68	113																		
[°C]	-7	49	18	49	1697,4	5797	1460,8	2,15	7,36	1,85	788,0	3,82	22,04							ARI540 MBP		
[°F]	20	120	65	120																		
[°C]	-10	45	32	45	1659,8	5668	1428,4	2,27	7,77	1,96	729,8	3,57	18,99							opt		
[°F]	14	113	90	113																		
[°C]	-25	45	32	45	850,3	2904	731,8	1,55	5,30	1,34	547,5	2,83	9,59							opt		
[°F]	-13	113	90	113																		

Performance tables

R290, 230V/60Hz, CSCR, fan 3m/s, UL

	pe		Cooling capacity			COP	EER		P1	I	m
	[°C]	[°F]	[W]	[Btu/h]	[kcal/h]	[W/W]	[Btu/Wh]	[kcal/Wh]	[W]	[A]	[kg/h]
[°C / °F]	-25	-13	850,3	2904	731,8	1,55	5,30	1,34	547,5	2,83	9,59
cond. pressure	-23	-10	929,8	3176	800,2	1,63	5,58	1,41	568,9	2,92	10,50
pc= 45/113	-15	5	1363,9	4658	1173,8	2,02	6,92	1,74	673,6	3,34	15,52
return gas temp.	-9	15	1694,5	5787	1458,3	2,30	7,87	1,98	735,5	3,59	19,40
RGT= 32/90	-4	25	2065,6	7055	1777,7	2,63	8,98	2,26	785,5	3,78	23,82
liquid temp	0	32	2352,9	8035	2024,9	2,90	9,91	2,50	810,7	3,86	27,29
Tliq= 45/113	7,2	45	2954,5	10090	2542,7	3,56	12,16	3,06	830,0	3,91	34,71
[°C / °F]	-25	-13	682,7	2332	587,6	1,23	4,19	1,06	556,5	2,91	8,50
cond. pressure	-23	-10	755,2	2579	649,9	1,30	4,44	1,12	580,9	3,01	9,42
pc= 55/131	-15	5	1152,5	3936	991,9	1,63	5,58	1,41	705,0	3,52	14,49
return gas temp	-9	15	1457,5	4978	1254,3	1,86	6,35	1,60	783,6	3,84	18,45
RGT= 32/90	-4	25	1801,8	6154	1550,7	2,11	7,21	1,82	853,4	4,11	22,99
liquid temp	0	32	2069,7	7068	1781,2	2,31	7,90	1,99	894,3	4,26	26,58
Tliq= 55/131	7,2	45	2634,2	8996	2267,0	2,78	9,50	2,39	946,7	4,44	34,32