

Model

Designation	SCE18MNX	208-230V/60Hz 1~	Sales code:	104H8889
-------------	-----------------	------------------	-------------	-----------------

Compressor design

Oil type	Polyolester	Refrigerant(s)	R290
Oil viscosity	32cSt	Displacement	17,69cm ³ / 1,08cu.in
Oil quantity	550cm ³ / 18,6fl.oz	Compressors on pallet	80
Refr. charge - tech. limit	450g / 15,9oz		
Free gas volume comp.	1460cm ³ / 49,4fl.oz		
Weight	14,2kg / 31,3lbs		
Motor protection	external		
Winding resistance main	2,6Ω (at 25°C)		
Winding resistance aux	21,2Ω (at 25°C)		
Max. winding temp.	125°C / 257°F		
Max. discharge temp.	135°C / 275°F		



General - Configurations with SCE18MNX

	Conf. 1
Motorconfiguration	CSIR
Power supply (nominal)	208-230V/60Hz
Number of phases	1
Voltage range	187-253V
Approvals	UL, KC, CB
Starting torque	HST
Note	Protector, relay and cover are included and pre-assembled to compressor.

Applications with SCE18MNX

	Conf. 1
Refrigerant	R290
Application	MBP
System cooling	fan 3m/s
Hot gas defrost	OK
Long interval pull down	OK

Electrical data - Configurations with SCE18MNX

	Conf. 1
Starting device type	relay
Run capacitor	-/-
Start capacitor	60μF
LRA (locked rotor amps / 4s/ U(N))	27,7A
RLA (rated load amps / 1s/ U(N))	5,2A
Cut in current (U(N))	27,7A

Model

Designation

SCE18MNX

208-230V/60Hz 1~

Sales code:

104H8889

Compressor dimensions

Housing	A Height	219mm / 8,62in
	B Height	213mm / 8,39in
	C Length shell	218mm / 8,58in
	D Length w. cover	255mm / 10,04in
	E Width	151mm / 5,94in

Connectors		Suction	Discharge	Process
		X	Y	Z
Diameter	[mm]	øi 9,54-9,72	øi 6,41-6,59	øi 6,41-6,59
(i:inside, o:outside)	[in]	øi 0,38-0,38	øi 0,25-0,26	øi 0,25-0,26
Material		copper	copper	copper
Horizontal angle	±2°	37°	37°	143°
Vertical angle	±2°	30°	0°	150°
Position l/h/w	[mm]	107/193/55	115/110/63	-107/193/55
	[in]	4,2/7,6/2,2	4,5/4,3/2,5	-4,2/7,6/2,2
Straight tube l.	[mm]	12	12	12
	[in]	0,5	0,5	0,5

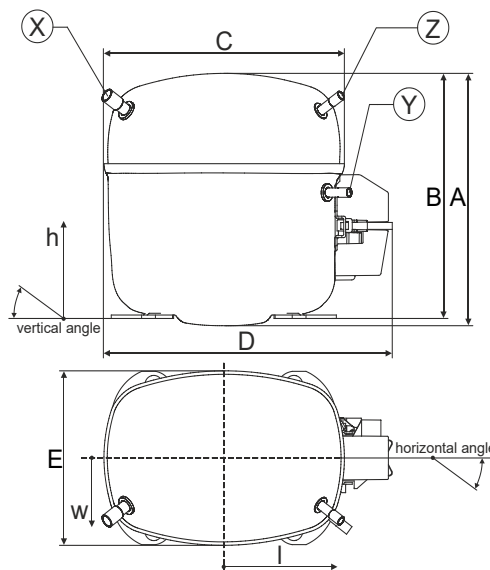

Compressor fixation

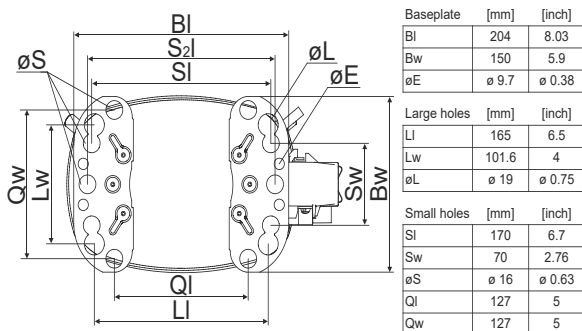

Bolt joint

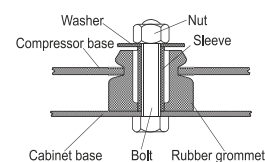

Snap-on

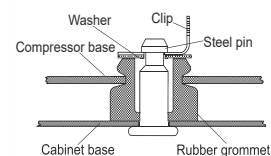

Mounting accessories

Mounting accessories	one comp.	multi pack
Bolt joint M6 ø16mm	118-1917	118-1918
Bolt joint ø1/4" ø16mm	118-1946	
Bolt joint ø1/4" ø19mm	118-1949	
Snap-on ø7,3 ø16mm	118-1947	118-1919

Application notes

Provision for PE Grounding is located at the PE Stamp on the compressor

Model

Designation	SCE18MNX	208-230V/60Hz	Conf. 1	Sales code:	104H8889
-------------	-----------------	----------------------	----------------	-------------	-----------------

Configuration

Motor configuration	CSIR
Power supply (nominal)	208-230V/60Hz 1~
Refrigerant	R290
Application	MBP
Voltage range	187-253V
Starting torque	HST
Approvals	UL
	KC
	CB

Electrical accessories / wiring diagram

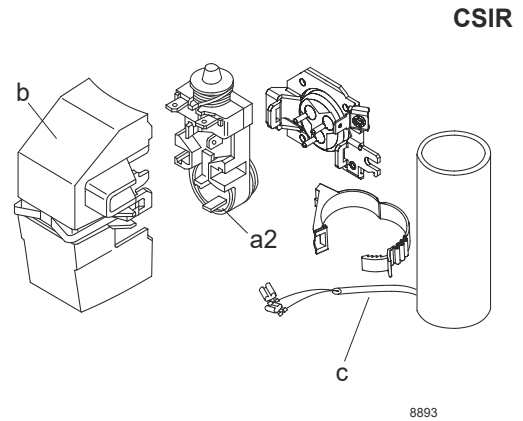

Ambient/ machine room temperatures minimum /maximum

Ambient temperature range:	10 - 43°C / 50 - 110°F
Machine room temperature range:	10 - 48°C / 50 - 119°F
Compressor cooling:	fan 3m/s

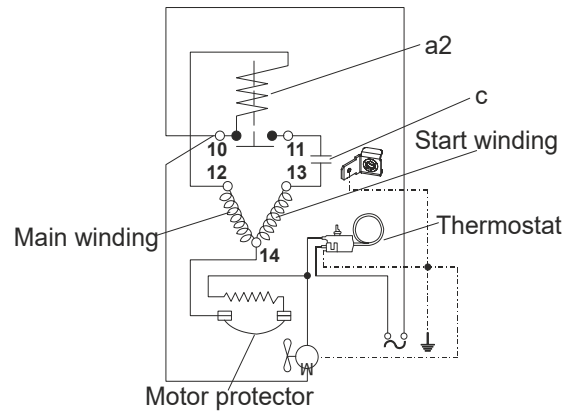

Operation pressure range

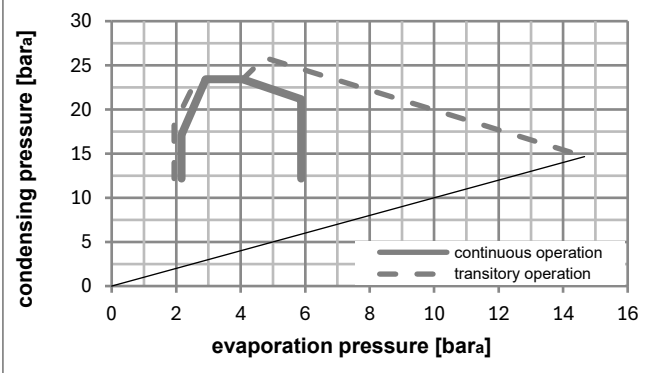
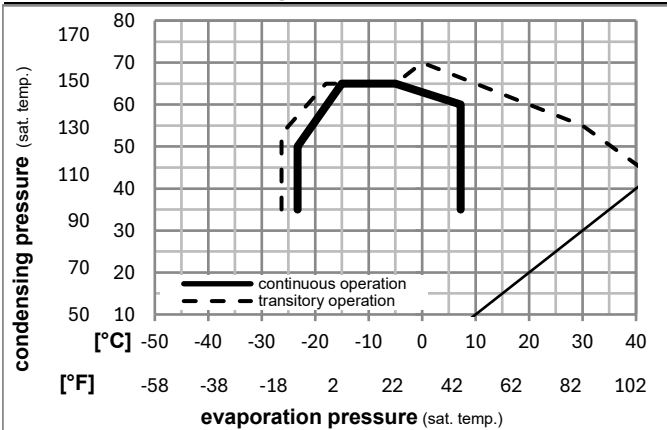

Components (relay (a2)+ cover (b): pre-assembled)

a2	assy. relay + ext. protector (T0715)	117U7412
c	start capacitor (60μF, 6.3mm, 82kOhm)	117U5076
b	plastic cover + clamp	117U1021

Noise emission

Operation pressures:	pe: -25°C / -13°F
	pc: 45°C / 113°F
Motor speed appr.:	3500rpm
Lw(A):	60dB(A)

Model

Designation **SCE18MNX** **208-230V/60Hz** Conf. 1 Sales code: **104H8889**

Optimization + standard conditions

R290, 230V/60Hz, CSIR, fan 3m/s, UL, KC, CB

		Evaporating pressure (saturation temperature)				Condensing pressure (saturation temperature)			Return gas temp.		Liquid temp.		Cooling capacity			COP	EER	P1	I	Ref. mass flow	
		pe	pc	RGT	Tliq	[W]	[Btu/h]	[kcal/h]	[W/W]	[Btu/Wh]	[kcal/Wh]	[W]	[A]	[kg/h]							
[°C]	-7	54	35	46	1796,4	6135	1546,0	1,96	6,71	1,69	914,3	5,07	20,49	ASHRAE MBP							
[°F]	20	130	95	115																	
[°C]	-10	55	32	55	1420,1	4850	1222,2	1,64	5,58	1,41	868,5	4,92	17,96	cecomaf MBP							
[°F]	14	131	90	131																	
[°C]	-10	45	20	45	1588,8	5426	1367,3	2,02	6,90	1,74	786,0	4,52	19,51	EN12900 MBP							
[°F]	14	113	68	113																	
[°C]	-7	49	18	49	1690,8	5775	1455,2	1,96	6,69	1,68	863,8	4,82	21,95	ARI540 MBP							
[°F]	20	120	65	120																	
[°C]	-10	45	32	45	1654,0	5649	1423,4	2,10	7,19	1,81	786,0	4,52	18,92	opt							
[°F]	14	113	90	113																	
[°C]	-25	45	32	45	849,0	2900	730,7	1,46	4,99	1,26	581,0	3,89	9,58	opt							
[°F]	-13	113	90	113																	

Performance tables

R290, 230V/60Hz, CSIR, fan 3m/s, UL, KC, CB

	pe		Cooling capacity			COP	EER	P1	I	m	
	[°C]	[°F]	[W]	[Btu/h]	[kcal/h]	[W/W]	[Btu/Wh]	[kcal/Wh]	[W]	[A]	[kg/h]
[°C / °F]	-25	-13	849,0	2900	730,7	1,46	4,99	1,26	581,0	3,89	9,58
cond. pressure	-23	-10	928,2	3170	798,8	1,53	5,24	1,32	605,3	3,96	10,48
pc= 45/113	-15	5	1359,9	4644	1170,3	1,88	6,42	1,62	723,2	4,31	15,47
return gas temp.	-9	15	1688,6	5767	1453,2	2,13	7,28	1,83	792,3	4,54	19,33
RGT= 32/90	-4	25	2057,6	7027	1770,8	2,43	8,29	2,09	847,7	4,73	23,73
liquid temp	0	32	2343,4	8003	2016,7	2,68	9,14	2,30	875,4	4,83	27,18
Tliq= 45/113	7,2	45	2942,6	10050	2532,4	3,28	11,22	2,83	896,0	4,92	34,57
[°C / °F]	-25	-13	681,9	2329	586,8	1,10	3,77	0,95	617,5	4,10	8,49
cond. pressure	-23	-10	754,0	2575	648,9	1,17	3,99	1,00	645,7	4,19	9,40
pc= 55/131	-15	5	1149,3	3925	989,1	1,46	4,98	1,26	787,7	4,65	14,45
return gas temp	-9	15	1452,1	4959	1249,7	1,66	5,65	1,42	877,0	4,95	18,38
RGT= 32/90	-4	25	1794,0	6127	1543,9	1,88	6,41	1,62	955,8	5,23	22,89
liquid temp	0	32	2060,1	7036	1772,9	2,06	7,02	1,77	1001,9	5,39	26,46
Tliq= 55/131	7,2	45	2621,1	8952	2255,8	2,47	8,44	2,13	1060,8	5,60	34,15