

## Model

Designation	<b>SCE23MNDX</b>	220-240V/50Hz 1~	Sales code:	<b>104H8300</b>
-------------	------------------	------------------	-------------	-----------------

## Compressor design

Oil type	Polyolester	Refrigerant(s)	<b>R290</b>
Oil viscosity	32cSt	Displacement	23cm <sup>3</sup> / 1,4cu.in
Oil quantity	500cm <sup>3</sup> / 16,9fl.oz	Compressors on pallet	48
Refr. charge - tech. limit	500g / 17,6oz		
Free gas volume comp.	3150cm <sup>3</sup> / 106,5fl.oz		
Weight	14,9kg / 32,8lbs		
Motor protection	1# internal		
Winding resistance main	2,8Ω (at 25°C)		
Winding resistance aux	10,9Ω (at 25°C)		
Max. winding temp.	125°C / 257°F		
Max. discharge temp.	140°C / 284°F		



## General - Configurations with SCE23MNDX

	<b>Conf. 1</b>
Motorconfiguration	CSCR
Power supply (nominal)	220-240V/50Hz
Number of phases	1
Voltage range	198-254V
Approvals	VDE, CCC, CB
Starting torque	HST
Note	Starter kit(relay), cover and cord relief are included and pre-assembled.

## Applications with SCE23MNDX

	<b>Conf. 1</b>
Refrigerant	R290
Application	MBP
System cooling	fan 3m/s
Hot gas defrost	OK
Long interval pull down	OK

## Electrical data - Configurations with SCE23MNDX

	<b>Conf. 1</b>
Starting device type	relay
Run capacitor	10μF
Start capacitor	60μF
LRA (locked rotor amps / 4s/ U(N))	27,1A
RLA (rated load amps / 1s/ U(N))	4,7A
Cut in current (U(N))	27,1A

## Model

Designation

**SCE23MNDX**

220-240V/50Hz 1~

Sales code:

**104H8300**

## Compressor dimensions

Housing	A Height	236,4mm / 9,31in
	B Height	230,6mm / 9,08in
	C Length shell	217mm / 8,54in
	D Length w. cover	263,4mm / 10,37in
	E Width	161,1mm / 6,34in
	F Width with equipment	199mm / 7,83in

Connectors	Suction		Discharge		Process	
	X	Y	Z			
Diameter [mm]	øi 12,81-12,99	øi 8,11-8,29	øi 6,11-6,29			
(i:inside, o:outside) [in]	øi 0,5-0,51	øi 0,32-0,33	øi 0,24-0,25			
Material	steel/CU	copper	copper			
Horizontal angle ±2°	37°	37°	37°			
Vertical angle ±2°	36°	0°	36°			
Position l/h/w [mm]	-111/212/57	116/127/81	110/94/72			
[in]	-4,4/8,3/2,2	4,5/5/3,2	4,3/3,7/2,8			
Straight tube l. [mm]	12	12	12			
[in]	0,5	0,5	0,5			

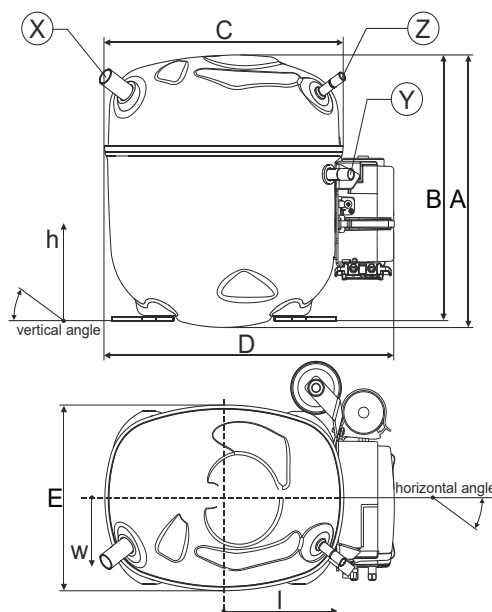

## Compressor fixation

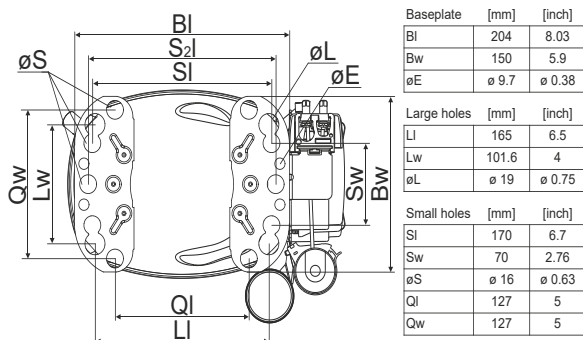

## Bolt joint



## Snap-on

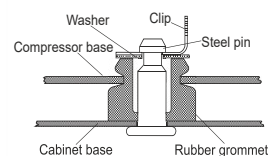

## Mounting accessories

Mounting accessories	one comp.	multi pack
Bolt joint   M6   ø16mm	118-1917	118-1918
Bolt joint   ø1/4"   ø16mm	118-1946	
Bolt joint   ø1/4"   ø19mm	118-1949	
Snap-on   ø7,3   ø16mm	118-1947	118-1919

## Application notes

Provision for PE Grounding is located at the PE Stamp on the compressor

## Model

Designation	<b>SCE23MNDX</b>	<b>220-240V/50Hz</b>	<b>Conf. 1</b>	Sales code:	<b>104H8300</b>
-------------	------------------	----------------------	----------------	-------------	-----------------

## Configuration

Motorconfiguration	CSCR
Power supply (nominal)	220-240V/50Hz 1~
Refrigerant	R290
Application	MBP
Voltage range	198-254V
Starting torque	HST
Approvals	VDE
	CCC
	CB

## Electrical accessories / wiring diagram

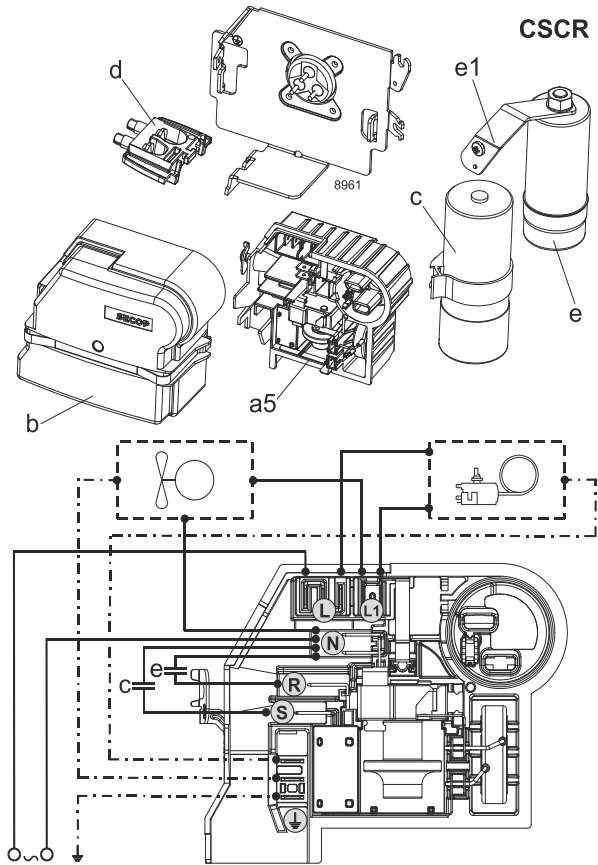

## Ambient/ machine room temperatures minimum /maximum

Ambient temperature range:	10 - 43°C / 50 - 110°F
Machine room temperature range:	10 - 48°C / 50 - 119°F
Compressor cooling:	fan 3m/s

## Operation pressure range

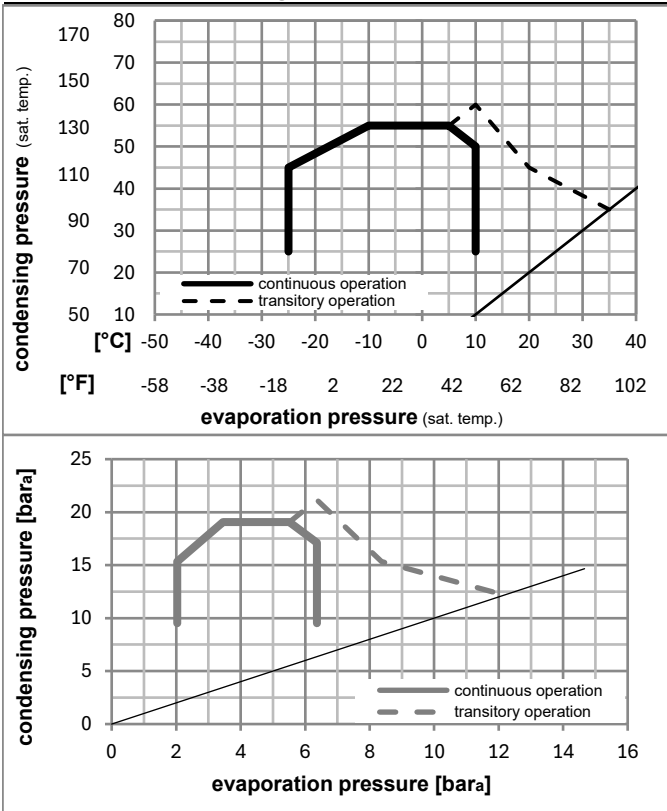

## Components (Starter kit (a5)+cover (b) +cord relief (d): pre assembled)

a5	SC starter kit	117U8100
b	cover terminal board + clamp	117U1036
c	start capacitor (60µF)	117U5351
e	run capacitor (10µF, 6.3mm)	117-7166
e1	retaining clamp	117-0313
	screw M4x8mm	117-0301
d	cord relief	103N1007

## Model

Designation **SCE23MNDX 220-240V/50Hz** Conf. 1 Sales code: **104H8300**

## Optimization + standard conditions

R290, 220V/50Hz, CSCR, fan 3m/s, VDE, CCC, CB

		Evaporating pressure (saturation temperature)				Condensing pressure (saturation temperature)			Return gas temp.		Liquid temp.		Cooling capacity			COP	EER	Power consumption		
		pe	pc	RGT	Tliq	[W]	[Btu/h]	[kcal/h]	[W/W]	[Btu/Wh]	[kcal/Wh]	P1	I	Ref. mass flow						
[°C]	[°F]											[W]	[A]	[kg/h]						
[°C]	-7	54	35	46	1911,4	6528	1645,0	2,09	7,13	1,80	915,5	4,35	21,80		<b>ASHRAE MBP</b>					
[°F]	20	130	95	115																
[°C]	-10	55	32	55	1522,8	5201	1310,5	1,74	5,96	1,50	873,0	4,16	19,26		<b>cecomaf MBP</b>					
[°F]	14	131	90	131																
[°C]	-10	45	20	45	1700,6	5808	1463,6	2,13	7,29	1,84	796,8	3,83	20,88		<b>EN12900 MBP</b>					
[°F]	14	113	68	113																
[°C]	-7	49	18	49	1801,5	6152	1550,4	2,08	7,12	1,79	864,6	4,12	23,39		<b>ARI540 MBP</b>					
[°F]	20	120	65	120																
[°C]	-10	45	32	45	1770,4	6046	1523,7	2,22	7,59	1,91	796,8	3,83	20,25		<b>opt</b>					
[°F]	14	113	90	113																
[°C]	-25	45	32	45	971,2	3317	835,8	1,59	5,44	1,37	609,2	3,05	10,95		<b>opt</b>					
[°F]	-13	113	90	113																

## Performance tables

R290, 220V/50Hz, CSCR, fan 3m/s, VDE, CCC, CB

	pe		Cooling capacity			COP	EER	P1	I	m	
	[°C]	[°F]	[W]	[Btu/h]	[kcal/h]	[W/W]	[Btu/Wh]	[kcal/Wh]	[W]	[A]	[kg/h]
[°C / °F]	-20	-4	1207,6	4124	1039,3	1,79	6,12	1,54	674,2	3,31	13,67
cond. pressure	-20	-4	1207,6	4124	1039,3	1,79	6,12	1,54	674,2	3,31	13,67
pc= 45/113	-15	5	1471,0	5024	1266,0	1,99	6,81	1,72	737,5	3,58	16,74
return gas temp.	-10	14	1770,4	6046	1523,7	2,22	7,59	1,91	796,8	3,83	20,25
RGT= 32/90	0	32	2513,1	8583	2162,8	2,81	9,59	2,42	894,9	4,26	29,15
liquid temp	5	41	2974,3	10158	2559,7	3,20	10,93	2,75	929,4	4,41	34,80
Tliq= 45/113	10	50	3507,3	11978	3018,5	3,69	12,59	3,17	951,2	4,51	41,44
[°C / °F]	-20	-4	1016,9	3473	875,2	1,41	4,83	1,22	719,1	3,50	12,72
cond. pressure	-20	-4	1016,9	3473	875,2	1,41	4,83	1,22	719,1	3,50	12,72
pc= 55/131	-15	5	1255,3	4287	1080,3	1,57	5,38	1,35	797,3	3,83	15,78
return gas temp	-10	14	1522,8	5201	1310,5	1,74	5,96	1,50	873,0	4,16	19,26
RGT= 32/90	0	32	2181,1	7449	1877,1	2,16	7,39	1,86	1008,3	4,76	28,01
liquid temp	5	41	2589,8	8845	2228,8	2,43	8,32	2,10	1063,6	5,01	33,58
Tliq= 55/131	10	50	3063,5	10463	2636,5	2,77	9,45	2,38	1107,7	5,21	40,17