

Model

Designation	SCE25MNDX	220-240V/50Hz 1~	Sales code:	104H8400
-------------	------------------	------------------	-------------	-----------------

Compressor design

Oil type	Polyolester	Refrigerant(s)	R290
Oil viscosity	32cSt	Displacement	25cm ³ / 1,53cu.in
Oil quantity	500cm ³ / 16,9fl.oz	Compressors on pallet	48
Refr. charge - tech. limit	500g / 17,6oz		
Free gas volume comp.	3150cm ³ / 106,5fl.oz		
Weight	14,9kg / 32,8lbs		
Motor protection	1# internal		
Winding resistance main	2,76Ω (at 25°C)		
Winding resistance aux	10,88Ω (at 25°C)		
Max. winding temp.	125°C / 257°F		
Max. discharge temp.	140°C / 284°F		



General - Configurations with SCE25MNDX

	Conf. 1
Motorconfiguration	CSCR
Power supply (nominal)	220-240V/50Hz
Number of phases	1
Voltage range	198-254V
Approvals	VDE, CCC, CB
Starting torque	HST
Note	Starter kit(relay), cover and cord relief are included and pre-assembled.

Applications with SCE25MNDX

	Conf. 1
Refrigerant	R290
Application	MBP
System cooling	fan 3m/s
Hot gas defrost	OK
Long interval pull down	OK

Electrical data - Configurations with SCE25MNDX

	Conf. 1
Starting device type	relay
Run capacitor	15μF
Start capacitor	60μF
LRA (locked rotor amps / 4s/ U(N))	25,45A
RLA (rated load amps / 1s/ U(N))	4,66A
Cut in current (U(N))	25,45A

Model

Designation

SCE25MNDX

220-240V/50Hz 1~

Sales code:

104H8400

Compressor dimensions

Housing	A Height	236,4mm / 9,31in
	B Height	230,6mm / 9,08in
	C Length shell	217mm / 8,54in
	D Length w. cover	263,4mm / 10,37in
	E Width	161,1mm / 6,34in
	F Width with equipment	199mm / 7,83in

Connectors	Suction		Discharge		Process	
	X	Y	Z			
Diameter [mm]	øi 12,81-12,99	øi 8,11-8,29	øi 6,11-6,29			
(i:inside, o:outside) [in]	øi 0,5-0,51	øi 0,32-0,33	øi 0,24-0,25			
Material	steel/CU	copper	copper			
Horizontal angle ±2°	37°	37°	37°			
Vertical angle ±2°	36°	0°	36°			
Position l/h/w [mm]	-111/212/57	116/127/81	110/94/72			
	-4,4/8,3/2,2	4,5/5/3,2	4,3/3,7/2,8			
Straight tube l. [mm]	12	12	12			
	0,5	0,5	0,5			

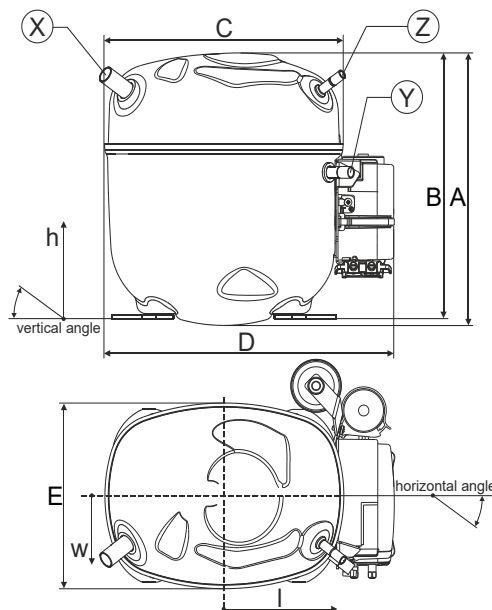

Compressor fixation

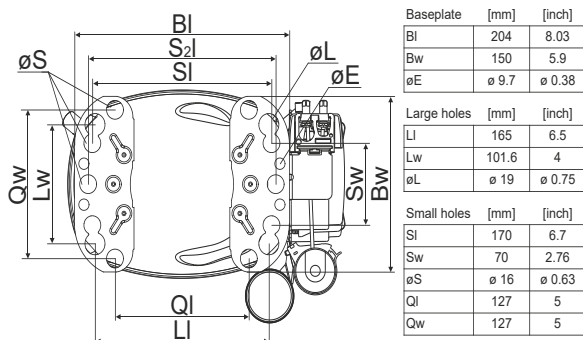

Bolt joint



Snap-on

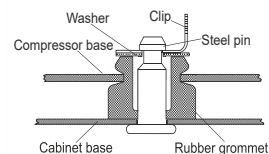

Mounting accessories

Mounting accessories	one comp.	multi pack
Bolt joint M6 ø16mm	118-1917	118-1918
Bolt joint ø1/4" ø16mm	118-1946	
Bolt joint ø1/4" ø19mm	118-1949	
Snap-on ø7,3 ø16mm	118-1947	118-1919

Application notes

Provision for PE Grounding is located at the PE Stamp on the compressor

Model

Designation	SCE25MNDX	220-240V/50Hz	Conf. 1	Sales code:	104H8400
-------------	------------------	----------------------	----------------	-------------	-----------------

Configuration

Motorconfiguration	CSCR
Power supply (nominal)	220-240V/50Hz 1~
Refrigerant	R290
Application	MBP
Voltage range	198-254V
Starting torque	HST
Approvals	VDE
	CCC
	CB

Electrical accessories / wiring diagram

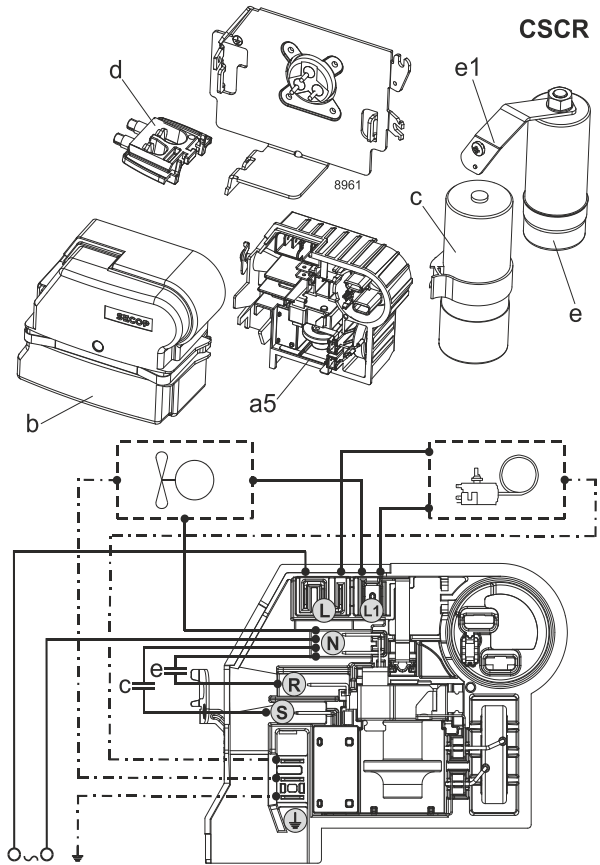

Ambient/ machine room temperatures minimum /maximum

Ambient temperature range:	10 - 43°C / 50 - 110°F
Machine room temperature range:	10 - 48°C / 50 - 119°F
Compressor cooling:	fan 3m/s

Operation pressure range

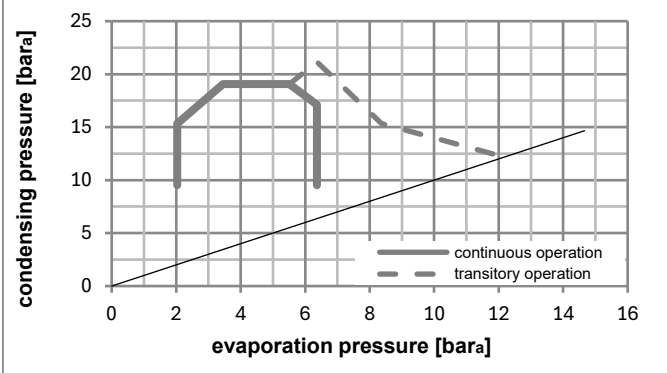
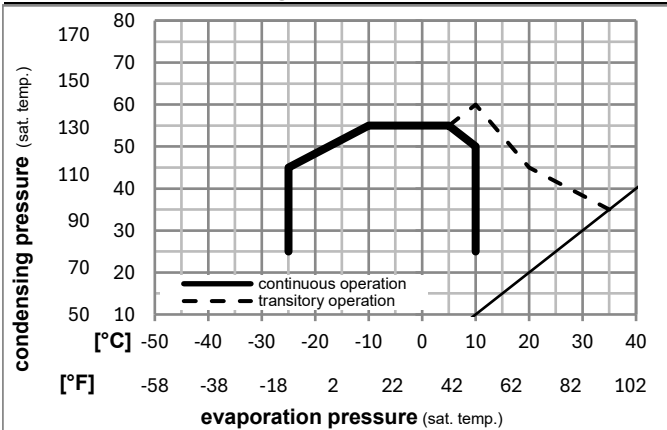

Components (Starter kit (a5)+cover (b) +cord relief (d): pre assembled)

a5	SC starter kit	117U8100
b	cover terminal board + clamp	117U1036
c	start capacitor (60μF)	117U5351
e	run capacitor (15μF, 6.3mm)	117-7167
e1	retaining clamp	117-0313
	screw M4x8mm	117-0301
d	cord relief	103N1007

Model

Designation **SCE25MNDX 220-240V/50Hz** Conf. 1 Sales code: **104H8400**

Optimization + standard conditions

R290, 220V/50Hz, CSCR, fan 3m/s, VDE, CCC, CB

		Evaporating pressure (saturation temperature)				Cooling capacity			COP	EER	Power consumption				
		Condensing pressure (saturation temperature)				Return gas temp.					Current consumption				
		Liquid temp.				Cooling capacity					Ref. mass flow				
		pe	pc	RGT	Tliq	[W]	[Btu/h]	[kcal/h]	[W/W]	[Btu/Wh]	[kcal/Wh]	P1	I	m	
[°C]	[°F]	[°C]	[°F]	[°C]	[°F]	[W]	[Btu/h]	[kcal/h]	[W/W]	[Btu/Wh]	[kcal/Wh]	[W]	[A]	[kg/h]	
[°C]	-7	54	35	46	2079,2	7101	1789,4	2,01	6,85	1,73	1036,5	4,89	23,72	ASHRAE MBP	
[°F]	20	130	95	115											
[°C]	-10	55	32	55	1659,7	5668	1428,4	1,67	5,72	1,44	991,8	4,69	20,99	cecomaf MBP	
[°F]	14	131	90	131											
[°C]	-10	45	20	45	1837,9	6277	1581,7	2,08	7,12	1,79	882,0	4,20	22,57	EN12900 MBP	
[°F]	14	113	68	113											
[°C]	-7	49	18	49	1954,3	6674	1681,9	2,02	6,91	1,74	965,3	4,57	25,38	ARI540 MBP	
[°F]	20	120	65	120											
[°C]	-10	45	32	45	1913,4	6534	1646,7	2,17	7,41	1,87	882,0	4,20	21,89	opt	
[°F]	14	113	90	113											
[°C]	-25	45	32	45	1043,8	3565	898,3	1,53	5,23	1,32	681,0	3,34	11,77	opt	
[°F]	-13	113	90	113											

Performance tables

R290, 220V/50Hz, CSCR, fan 3m/s, VDE, CCC, CB

	pe		Cooling capacity			COP	EER	P1	I	m	
	[°C]	[°F]	[W]	[Btu/h]	[kcal/h]	[W/W]	[Btu/Wh]	[kcal/Wh]	[W]	[A]	[kg/h]
[°C / °F]	-25	-13	1043,8	3565	898,3	1,53	5,23	1,32	681,0	3,34	11,77
cond. pressure	-20	-4	1298,9	4436	1117,9	1,73	5,90	1,49	752,4	3,64	14,71
pc= 45/113	-15	5	1585,1	5413	1364,2	1,93	6,60	1,66	819,7	3,93	18,03
return gas temp.	-10	14	1913,4	6534	1646,7	2,17	7,41	1,87	882,0	4,20	21,89
RGT= 32/90	0	32	2740,5	9359	2358,5	2,78	9,48	2,39	986,9	4,67	31,79
liquid temp	5	41	3261,4	11138	2806,8	3,17	10,84	2,73	1027,5	4,85	38,16
Tliq= 45/113	10	50	3868,8	13213	3329,5	3,65	12,48	3,15	1058,6	4,99	45,72
[°C / °F]	-25	-13	868,5	2966	747,5	1,20	4,11	1,04	722,1	3,51	10,81
cond. pressure	-20	-4	1111,2	3795	956,3	1,36	4,64	1,17	817,7	3,92	13,90
pc= 55/131	-15	5	1371,2	4683	1180,1	1,51	5,16	1,30	908,0	4,31	17,24
return gas temp	-10	14	1659,7	5668	1428,4	1,67	5,72	1,44	991,8	4,69	20,99
RGT= 32/90	0	32	2366,5	8082	2036,7	2,08	7,12	1,79	1135,7	5,34	30,40
liquid temp	5	41	2807,0	9586	2415,7	2,35	8,03	2,02	1193,7	5,60	36,40
Tliq= 55/131	10	50	3320,2	11339	2857,4	2,68	9,14	2,30	1240,9	5,82	43,53