

Model

Designation	TF4CLX	115-127V/60Hz 1~	Sales code:	102U2124
-------------	---------------	------------------	-------------	-----------------

Compressor design

Oil type	Polyolester	Refrigerant(s)	R404A, R507, R452A
Oil viscosity	32cST	Displacement	3,86cm ³ / 0,24cu.in
Oil quantity	283cm ³ / 9,6fl.oz	Compressors on pallet	100
Refr. charge - tech. limit	600g / 21,2oz		
Free gas volume comp.	1690cm ³ / 57,1fl.oz		
Weight	8,1kg / 17,9lbs		
Motor protection	external		
Winding resistance main	2,6Ω (at 25°C)		
Winding resistance aux	3,8Ω (at 25°C)		
Max. winding temp.	125°C / 257°F		
Max. discharge temp.	130°C / 266°F		



General - Configurations with TF4CLX

	Conf. 1	Conf. 2
Motorconfiguration	CSIR	CSIR
Power supply (nominal)	115V/60Hz	115V/60Hz
Number of phases	1	1
Voltage range	103-135V	103-135V
Approvals	UL	UL
Starting torque	HST	HST
Note	Electrical equipment is included and pre-assembled to compressor.	

Applications with TF4CLX

	Conf. 1	Conf. 2
Refrigerant	R404A	R452A
Application	LBP+MBP	LBP+MBP
System cooling	fan 1,5m/s	fan 1,5m/s
Hot gas defrost	OK	OK
Long interval pull down	OK	OK

Electrical data - Configurations with TF4CLX

	Conf. 1	Conf. 2
Starting device type	relay	relay
Run capacitor	-/-	-/-
Start capacitor	280μF	280μF
LRA (locked rotor amps / 4s)	20A	20A
RLA (rated load amps / 1s)	3,2A	3,2A
Cut in current	20A	20A

Model

Designation

TF4CLX

115-127V/60Hz 1~

Sales code:

102U2124

Compressor dimensions

Housing	A Height	174mm / 6,85in
	B Height	168mm / 6,61in
	C Length shell	176,5mm / 6,95in
	D Length w. cover	226mm / 8,9in
	E Width	156mm / 6,14in

Connectors		Suction	Discharge	Process
		X	Y	Z
Diameter	[mm]	øi 6,41-6,59	øi 5,12-5,22	øi 6,41-6,59
	(i:inside, o:outside) [in]	øi 0,25-0,26	øi 0,2-0,21	øi 0,25-0,26
Material		copper	copper	copper
Horizontal angle	±2°	0°	0°	0°
Vertical angle	±2°	150°	28°	31,5°
Position l/h/w	[mm]	-102/105/66	117/107/29	96/105/71
	[in]	-4/4,1/2,6	4,6/4,2/1,1	3,8/4,1/2,8
Straight tube l.	[mm]	12	12	12
	[in]	0,5	0,5	0,5

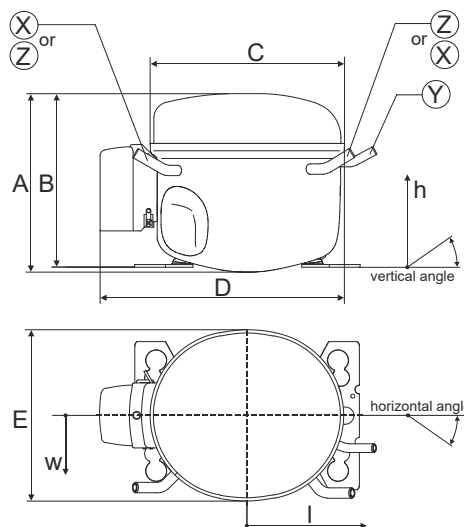

Compressor fixation

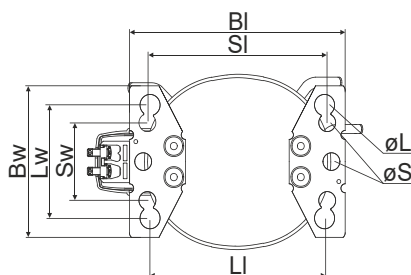

Baseplate	[mm]	[inch]
BI	204	8.03
Bw	136	5.35
Large holes		
LI	165	6.5
Lw	101.6	4
øL	ø 19	ø 0.75
Small holes		
SI	170	6.7
Sw	70	2.76
øS	ø 16	ø 0.63

Bolt joint

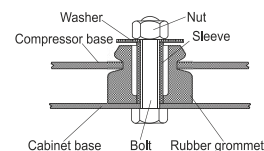

Snap-on

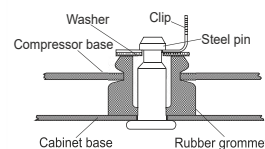

Mounting accessories

	one comp.	multi pack
Bolt joint M6 ø16mm	118-1917	118-1918
Bolt joint ø1/4" ø16mm	118-1946	
Bolt joint ø1/4" ø19mm	118-1949	
Snap-on ø7,3 ø16mm	118-1947	118-1919

Application notes

LRA value on compressor label and datasheet may differ due to different test conditions for UL approval.

Model

Designation	TF4CLX	115V/60Hz	Conf. 1	Sales code:	102U2124
-------------	---------------	------------------	----------------	-------------	-----------------

Configuration

Motor configuration	CSIR	
Power supply (nominal)	115V/60Hz 1~	
Refrigerant	R404A	
Application	LBP+MBP	
Voltage range	103-135V	
Starting torque	HST	
Approvals	UL	SA3693

Electrical accessories / wiring diagram

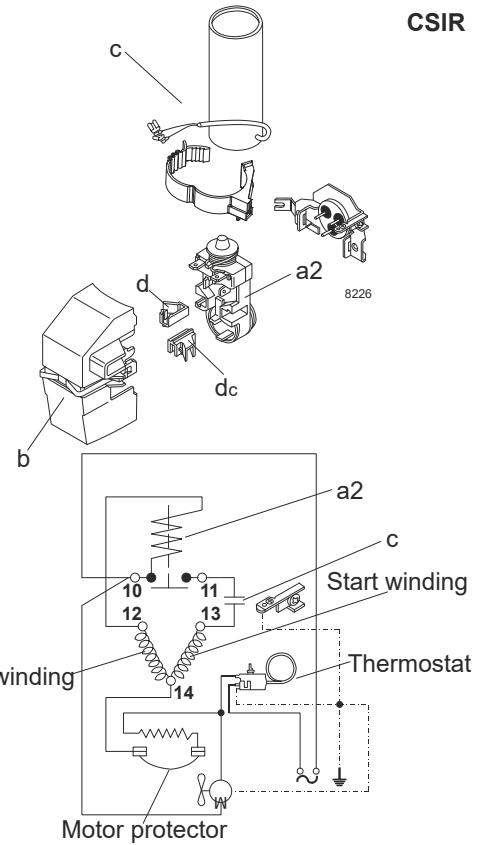

Ambient temperatures / system cooling

Ambient temperature min.:	10°C / 50°F
Ambient temperature max.:	43°C / 110°F

System cooling (n/a: outside limits)			
T ambient	LBP	MBP	HBP
32°C / 90°F	fan 1,5m/s	fan 1,5m/s	n/a
38°C / 100°F	fan 1,5m/s	fan 1,5m/s	n/a
43°C / 110°F	fan 1,5m/s	fan 1,5m/s	n/a

Operation pressure range

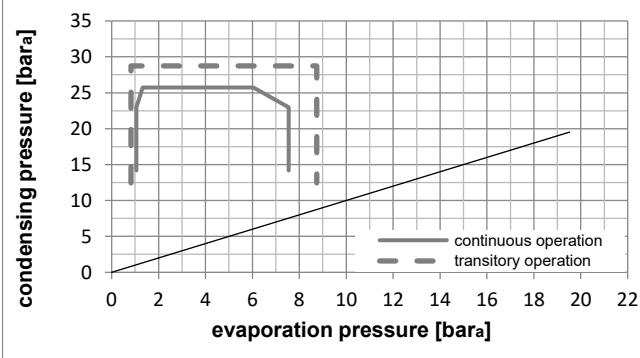
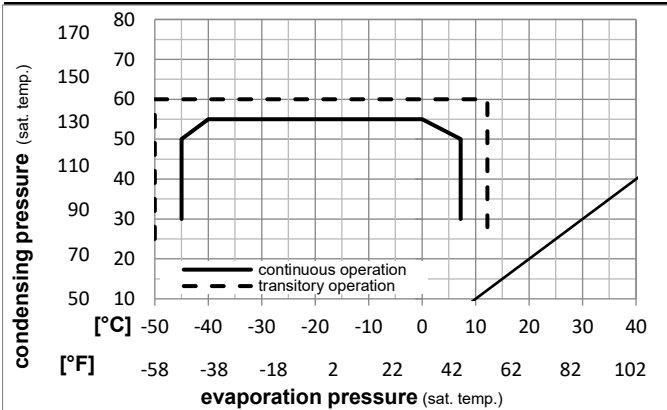

Components (already pre-assembled)

a2	assy. relay + ext. protector (MRP36EN-6)	117U4148
c	start capacitor (280µF)	117U5025
b	plastic cover	117U1021
d/dc	cord relief	117U0349
d/dc	cord relief	117U0349

Alternative components

b	plastic cover	117U1027
---	---------------	----------

Model

Designation **TF4CLX** **115V/60Hz** Conf. 1 Sales code: **102U2124**

Optimization + standard conditions

R404A, 115V/60Hz, CSIR, fan 3m/s, UL

		Evaporating pressure (saturation temperature)				Condensing pressure (saturation temperature)			Return gas temp.			Liquid temp.			Cooling capacity			COP	EER	Power consumption			
		pe	pc	RGT	Tliq	[W]	[Btu/h]	[kcal/h]	[W/W]	[Btu/Wh]	[kcal/Wh]	P1	I	Current consumption		Ref. mass flow							
[°C]	[°F]	[°C]	[°F]	[°C]	[°F]							[W]	[A]	[A]	[kg/h]		ASHRAE LBP						
-23	-10	54	130	32	90	205,8	703	177,1	1,12	3,83	0,96	183,6	2,46	4,80									
-25	-13	55	131	32	90	139,2	475	119,8	0,79	2,69	0,68	177,0	2,41	4,35			cecomaf LBP						
-35	-31	40	104	20	68	109,3	373	94,1	0,80	2,74	0,69	136,1	2,16	2,97			EN12900 LBP						
-23	-10	49	120	4,4	40	153,3	523	131,9	0,86	2,94	0,74	178,3	2,43	5,43			ARI540 LBP						
-23	-10	41	105	32	90	232,9	795	200,4	1,34	4,57	1,15	173,9	2,41	5,43			AHAM LBP						
-35	-31	45	113	32	90	100,5	343	86,5	0,74	2,53	0,64	135,8	2,14	2,69			opt						

Performance tables

R404A, 115V/60Hz, CSIR, fan 3m/s, UL

	pe		Cooling capacity			COP	EER	P1	I	m	
	[°C]	[°F]	[W]	[Btu/h]	[kcal/h]	[W/W]	[Btu/Wh]	[kcal/Wh]	[W]	[A]	[kg/h]
[°C / °F]	-45	-49	46,8	160	40,3	0,45	1,52	0,38	104,9	2,04	1,24
cond. pressure	-34	-30	104,2	356	89,6	0,76	2,59	0,65	137,5	2,15	2,79
pc= 45/113	-23	-10	193,6	661	166,6	1,10	3,76	0,95	175,8	2,41	5,23
return gas temp.	-15	5	284,9	973	245,2	1,34	4,58	1,15	212,5	2,70	7,78
RGT= 32/90	-4	25	445,3	1521	383,2	1,59	5,45	1,37	279,2	3,20	12,41
liquid temp	0	32	513,1	1752	441,6	1,66	5,67	1,43	308,9	3,41	14,43
Tliq= 45/113	7,2	45	657,0	2244	565,4	1,75	5,99	1,51	374,7	3,84	18,84
[°C / °F]	-45	-49	26,3	90	22,6	0,27	0,93	0,23	96,9	2,01	0,81
cond. pressure	-34	-30	76,6	262	65,9	0,55	1,88	0,47	138,9	2,17	2,37
pc= 55/131	-23	-10	152,3	520	131,1	0,83	2,82	0,71	184,3	2,47	4,77
return gas temp	-15	5	229,1	782	197,2	1,02	3,49	0,88	224,4	2,78	7,27
RGT= 32/90	-4	25	364,5	1245	313,7	1,24	4,25	1,07	293,2	3,32	11,83
liquid temp	0	32	422,1	1442	363,3	1,31	4,46	1,12	322,9	3,55	13,84
Tliq= 55/131	7,2	45	544,8	1861	468,9	1,40	4,80	1,21	387,8	4,01	18,29

Model

Designation	TF4CLX	115V/60Hz	Conf. 2	Sales code:	102U2124
-------------	---------------	------------------	----------------	-------------	-----------------

Configuration

Motorconfiguration	CSIR	
Power supply (nominal)	115V/60Hz 1~	
Refrigerant	R452A	
Application	LBP+MBP	
Voltage range	103-135V	
Starting torque	HST	
Approvals	UL	SA3693

Electrical accessories / wiring diagram

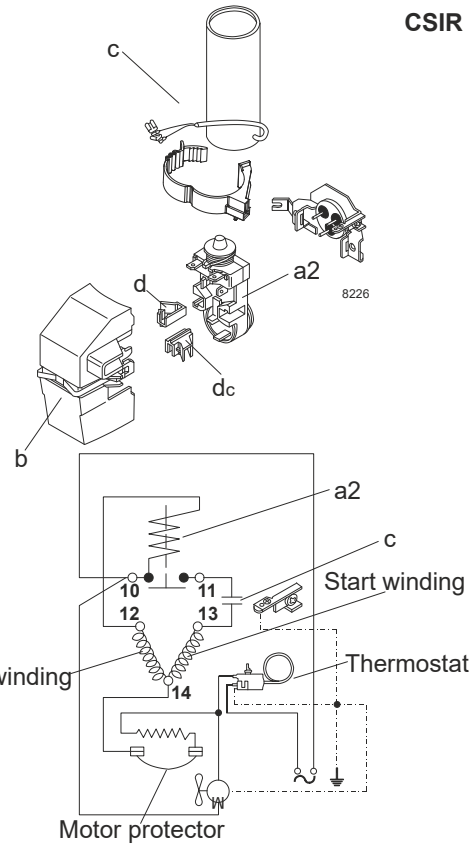

Ambient temperatures / system cooling

Ambient temperature min.:	10°C / 50°F
Ambient temperature max.:	43°C / 110°F

System cooling (n/a: outside limits)			
T ambient	LBP	MBP	HBP
32°C / 90°F	fan 1,5m/s	fan 1,5m/s	n/a
38°C / 100°F	fan 1,5m/s	fan 1,5m/s	n/a
43°C / 110°F	fan 1,5m/s	fan 1,5m/s	n/a

Operation pressure range

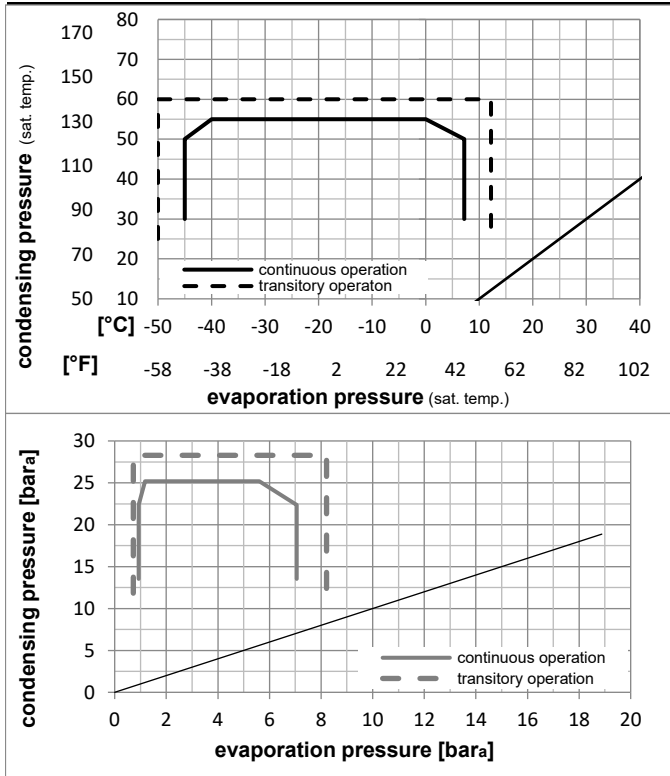

Components (already pre-assembled)

a2	assy. relay + ext. protector (MRP36EN-6)	117U4148
c	start capacitor (280µF)	117U5025
b	plastic cover	117U1021
d/dc	cord relief	117U0349
d/dc	cord relief	117U0349

Alternative components

b	plastic cover	117U1027
---	---------------	----------

Model

Designation	TF4CLX	115V/60Hz	Conf. 2	Sales code:	102U2124
-------------	---------------	------------------	----------------	-------------	-----------------

Optimization + standard conditions

R452A, 115V/60Hz, CSIR, fan 3m/s, UL

		Evaporating pressure (saturation temperature)				Condensing pressure (saturation temperature)					Power consumption				
		Return gas temp.			Liquid temp.		Cooling capacity			COP	EER	P1	Current consumption		Ref. mass flow
		pe	pc	RGT	Tliq	[W]	[Btu/h]	[kcal/h]	[W/W]	[Btu/Wh]	[kcal/Wh]	[W]	I	m	
[°C]	[°F]	[°C]	[°F]	[°C]	[°C]								[A]	[kg/h]	
[°C]	-23	54	32	32	187,7	641	161,5	1,09	3,71	0,93	172,8	2,43	4,51	ASHRAE LBP	
[°F]	-10	130	90	90											
[°C]	-25	55	32	55	128,0	437	110,1	0,77	2,63	0,66	166,3	2,39	4,07	cecomaf LBP	
[°F]	-13	131	90	131											
[°C]	-35	40	20	40	98,3	336	84,6	0,77	2,63	0,66	127,8	2,12	2,75	EN12900 LBP	
[°F]	-31	104	68	104											
[°C]	-23	49	4,4	49	142,0	485	122,2	0,84	2,89	0,73	168,1	2,40	5,11	ARI540 LBP	
[°F]	-10	120	40	120											
[°C]	-23	41	32	32	213,8	730	184,0	1,30	4,45	1,12	164,2	2,37	5,14	AHAM LBP	
[°F]	-10	105	90	90											
[°C]	-35	45	32	45	90,2	308	77,6	0,71	2,42	0,61	127,4	2,12	2,47	opt	
[°F]	-31	113	90	113											

Performance tables

R452A, 115V/60Hz, CSIR, fan 3m/s, UL

	pe		Cooling capacity			COP	EER		P1	I	m
	[°C]	[°F]	[W]	[Btu/h]	[kcal/h]	[W/W]	[Btu/Wh]	[kcal/Wh]	[W]	[A]	[kg/h]
[°C / °F]	-45	-49	39,8	136	34,3	0,40	1,37	0,35	99,1	1,92	1,09
cond. pressure	-34	-30	93,6	320	80,5	0,73	2,48	0,62	129,0	2,13	2,57
pc= 45/113	-23	-10	178,5	610	153,6	1,08	3,67	0,93	165,9	2,38	4,95
return gas temp.	-15	5	266,2	909	229,1	1,32	4,50	1,13	202,2	2,63	7,45
RGT= 32/90	-4	25	421,8	1440	363,0	1,57	5,36	1,35	268,7	3,09	12,01
liquid temp	0	32	488,1	1667	420,1	1,64	5,59	1,41	298,2	3,30	14,01
Tliq= 45/113	7,2	45	629,4	2149	541,6	1,73	5,91	1,49	363,5	3,75	18,39
[°C / °F]	-45	-49	21,2	72	18,2	0,23	0,80	0,20	90,8	1,86	0,66
cond. pressure	-34	-30	68,4	234	58,8	0,53	1,80	0,45	129,6	2,13	2,16
pc= 55/131	-23	-10	140,6	480	121,0	0,81	2,77	0,70	173,4	2,43	4,48
return gas temp	-15	5	214,8	734	184,9	1,01	3,44	0,87	213,2	2,71	6,92
RGT= 32/90	-4	25	347,3	1186	298,9	1,23	4,20	1,06	282,2	3,19	11,43
liquid temp	0	32	404,1	1380	347,7	1,29	4,42	1,11	312,1	3,39	13,42
Tliq= 55/131	7,2	45	525,7	1795	452,4	1,39	4,76	1,20	377,2	3,84	17,82