

Model

Designation	TFS4.5FT	115-127V/60Hz 1~	Sales code:	102G3451
-------------	-----------------	------------------	-------------	-----------------

Compressor design

Oil type	Polyolester	Refrigerant(s)	R134a, R513A, 0
Oil viscosity	15cST	Displacement	4,63cm ³ / 0,28cu.in
Oil quantity	285cm ³ / 9,7fl.oz	Compressors on pallet	125
Refr. charge - tech. limit	400g / 14,1oz		
Free gas volume comp.	1790cm ³ / 60,5fl.oz		
Weight	6,7kg / 14,8lbs		
Motor protection	external		
Winding resistance main	3,33Ω (at 25°C)		
Winding resistance aux	8,76Ω (at 25°C)		
Max. winding temp.	125°C / 257°F		
Max. discharge temp.	130°C / 266°F		



General - Configurations with TFS4.5FT

	Conf. 1	Conf. 2
Motorconfiguration	CSIR	RSIR
Power supply (nominal)	115-127V/60Hz	115-127V/60Hz
Number of phases	1	1
Voltage range	95-135V	95-135V
Approvals	UL	UL
Starting torque	HST	LST
Note	- / -	

Applications with TFS4.5FT

	Conf. 1	Conf. 2
Refrigerant	R134a	R134a
Application	LBP	LBP
System cooling	static	static
Hot gas defrost	-/-	-/-
Long interval pull down	-/-	-/-

Electrical data - Configurations with TFS4.5FT

	Conf. 1	Conf. 2
Starting device type	relay	PTC
Run capacitor	-/-	-/-
Start capacitor	320μF	-/-
LRA (locked rotor amps / 4s)	20,1A	
RLA (rated load amps / 1s)	2,4A	-/-A
Cut in current	20,1A	

Model

Designation

TFS4.5FT

115-127V/60Hz 1~

Sales code:

102G3451

Compressor dimensions

Housing	A Height	163,5mm / 6,44in
	B Height	159mm / 6,26in
	C Length shell	176,5mm / 6,95in
	D Length w. cover	222mm / 8,74in
	E Width	157mm / 6,18in

Connectors		Suction	Discharge	Process
		X	Y	Z
Diameter	[mm]	øi 8,11-8,29	øi 6,41-6,59	øi 6,41-6,59
	(i:inside, o:outside) [in]	øi 0,32-0,33	øi 0,25-0,26	øi 0,25-0,26
Material		steel/CU	steel/CU	steel/CU
Horizontal angle	±2°	51°	20°	135°
Vertical angle	±2°	90°	90°	90°
Position l/h/w	[mm]	72/116/75	96/116/31	-73/121/62
	[in]	2,8/4,6/2,9	3,8/4,6/1,2	-2,9/4,8/2,4
Straight tube l.	[mm]	12	12	12
	[in]	0,5	0,5	0,5

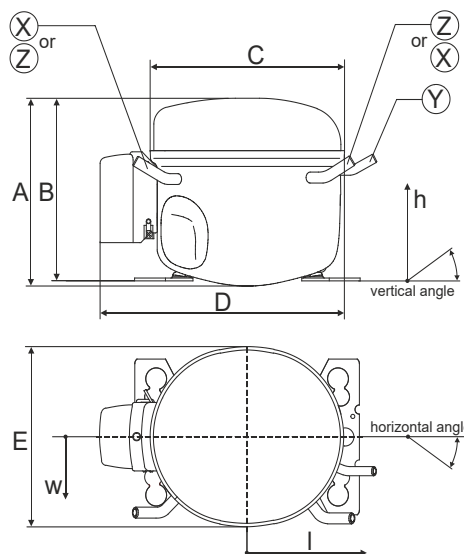

Compressor fixation

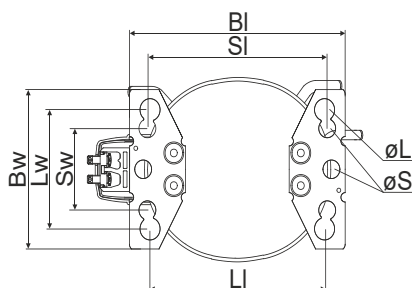

Baseplate	[mm]	[inch]
BI	204	8.03
Bw	136	5.35
Large holes		
LI	165	6.5
Lw	101.6	4
øL	ø 19	ø 0.75
Small holes		
SI	170	6.7
Sw	70	2.76
øS	ø 16	ø 0.63

Bolt joint

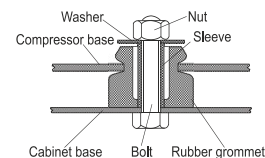

Snap-on

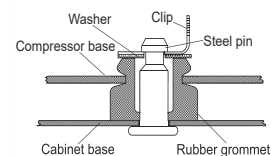

Mounting accessories	one comp.	multi pack
Bolt joint M6 ø16mm	118-1917	118-1918
Bolt joint ø1/4" ø16mm	118-1946	
Bolt joint ø1/4" ø19mm	118-1949	
Snap-on ø7,3 ø16mm	118-1947	118-1919

Application notes

Provision for PE Grounding is located at the PE Stamp on the compressor

Model

Designation	TFS4.5FT	115-127V/60Hz	Conf. 1	Sales code:	102G3451
-------------	-----------------	----------------------	---------	-------------	-----------------

Configuration

Motorconfiguration	CSIR
Power supply (nominal)	115-127V/60Hz 1~
Refrigerant	R134a
Application	LBP
Voltage range	95-135V
Starting torque	HST
Approvals	UL

Electrical accessories / wiring diagram

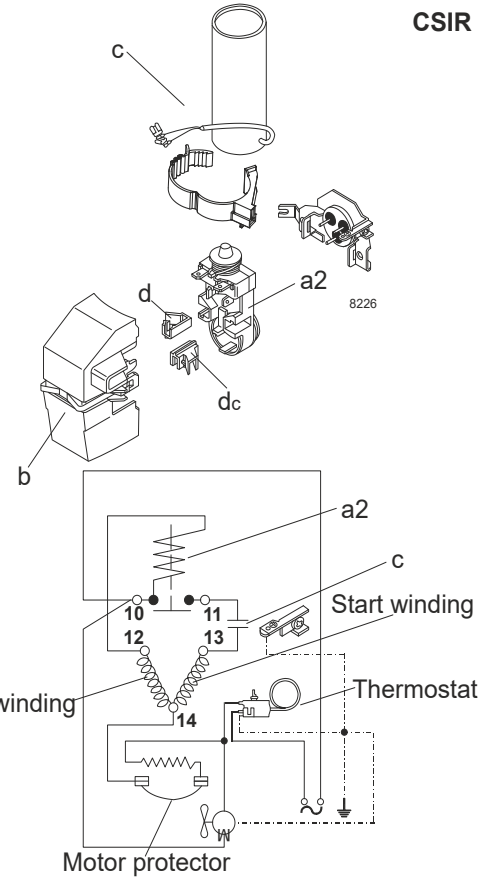

Ambient/ machine room temperatures minimum /maximum

Ambient temperature range:	10 - 43°C / 50 - 110°F
Machine room temperature range:	10 - 48°C / 50 - 119°F
Compressor cooling:	static

Operation pressure range

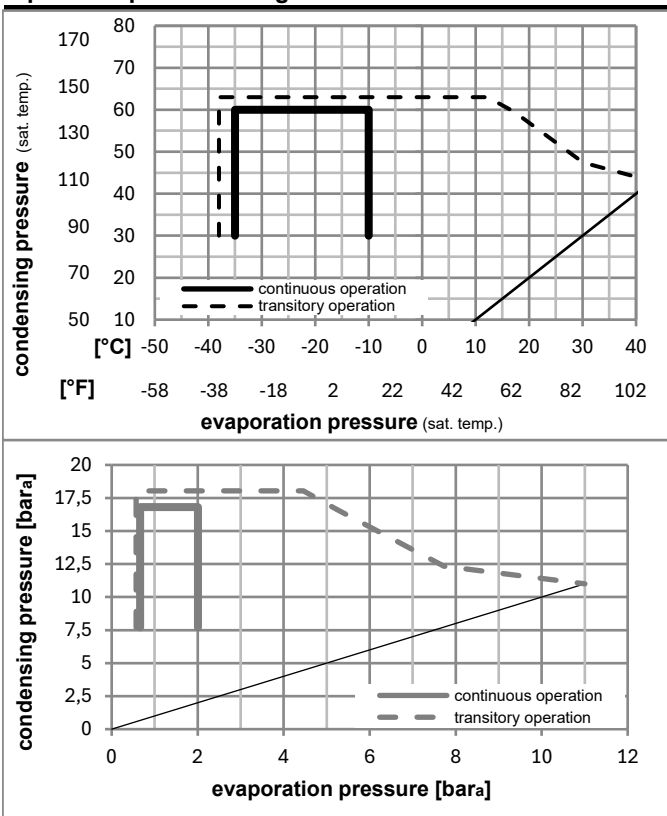

Components

a2	assy. relay + ext. protector (MRP39AIL-6)	117U4126
c	start capacitor (320µF)	117U5022
b	plastic cover	117U1021
d/dc	cord relief	117U0349
d/dc	cord relief	117U0349

Alternative components

b	plastic cover	117U1027
---	---------------	----------

Model

Designation **TFS4.5FT** **115-127V/60Hz** Conf. 1 Sales code: **102G3451**

Optimization + standard conditions

R134a, 115V/60Hz, CSIR, static, UL

		Evaporating pressure (saturation temperature)				Condensing pressure (saturation temperature)			Return gas temp.			Liquid temp.			Cooling capacity			COP	EER	Power consumption			ASHRAE LBP
		pe	pc	RGT	Tliq	[W]	[Btu/h]	[kcal/h]	[W/W]	[Btu/Wh]	[kcal/Wh]	P1	I	Ref. mass flow									
[°C]	[°F]											[W]	[A]	[kg/h]									
-23	54	32	32	139,8	477	120,3	1,10	3,76	0,95	127,1	2,02	2,71											
-10	130	90	90																				
-25	55	32	55	102,0	348	87,8	0,84	2,88	0,73	121,0	1,99	2,44											
-13	131	90	131																				
-35	40	20	40	82,3	281	70,8	0,88	3,01	0,76	93,5	1,87	1,81											
-31	104	68	104																				
-23	49	4,4	49	118,4	404	101,9	0,93	3,19	0,80	126,9	2,01	3,13											
-10	120	40	120																				
-23	41	32	32	165,1	564	142,1	1,32	4,50	1,13	125,3	1,99	3,20											
-10	105	90	90																				
-35	45	32	45	75,0	256	64,5	0,81	2,78	0,70	92,1	1,87	1,62											
-31	113	90	113																				

Performance tables

R134a, 115V/60Hz, CSIR, static, UL

	pe		Cooling capacity			COP	EER	P1	I	m	
	[°C]	[°F]	[W]	[Btu/h]	[kcal/h]	[W/W]	[Btu/Wh]	[kcal/Wh]	[W]	[A]	[kg/h]
[°C / °F]	-35	-31	75,0	256	64,5	0,81	2,78	0,70	92,1	1,87	1,62
cond. pressure	-29	-20	104,3	356	89,7	0,96	3,27	0,82	108,9	1,93	2,26
pc= 45/113	-26	-15	121,4	415	104,5	1,03	3,53	0,89	117,4	1,96	2,63
return gas temp.	-23	-10	141,0	481	121,3	1,12	3,81	0,96	126,3	2,00	3,06
RGT= 32/90	-21	-5	162,9	556	140,2	1,20	4,10	1,03	135,7	2,05	3,54
liquid temp	-15	5	214,2	732	184,4	1,37	4,69	1,18	156,0	2,16	4,67
Tliq= 45/113	-10	14	268,9	918	231,4	1,53	5,22	1,31	176,1	2,28	5,88
[°C / °F]	-35	-31	56,0	191	48,2	0,64	2,17	0,55	88,0	1,87	1,33
cond. pressure	-29	-20	80,4	275	69,2	0,75	2,55	0,64	107,5	1,94	1,92
pc= 55/131	-26	-15	95,3	326	82,1	0,81	2,78	0,70	117,1	1,98	2,28
return gas temp	-23	-10	112,8	385	97,0	0,89	3,03	0,76	127,1	2,02	2,70
RGT= 32/90	-21	-5	132,7	453	114,2	0,96	3,29	0,83	137,6	2,07	3,18
liquid temp	-15	5	179,9	614	154,8	1,12	3,84	0,97	160,1	2,18	4,33
Tliq= 55/131	-10	14	231,1	789	198,9	1,27	4,34	1,09	181,9	2,31	5,59

Model

Designation	TFS4.5FT	115-127V/60Hz	Conf. 2	Sales code:	102G3451
-------------	-----------------	----------------------	---------	-------------	-----------------

Configuration

Motorconfiguration	RSIR
Power supply (nominal)	115-127V/60Hz 1~
Refrigerant	R134a
Application	LBP
Voltage range	95-135V
Starting torque	LST
Approvals	UL

Electrical accessories / wiring diagram

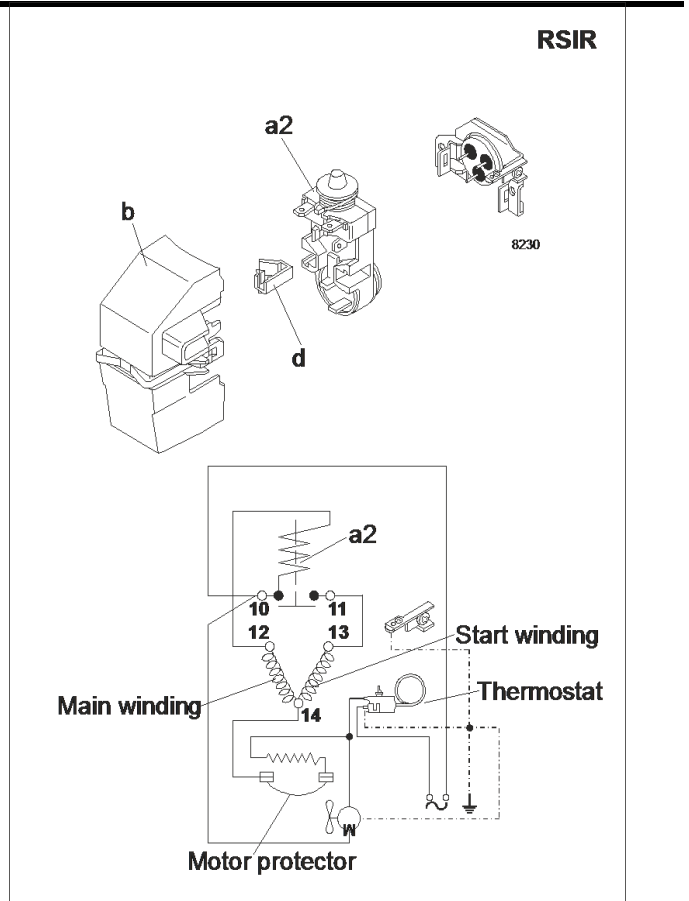

Ambient/ machine room temperatures minimum /maximum

Ambient temperature range:	10 - 43°C / 50 - 110°F
Machine room temperature range:	10 - 48°C / 50 - 119°F
Compressor cooling:	static

Operation pressure range

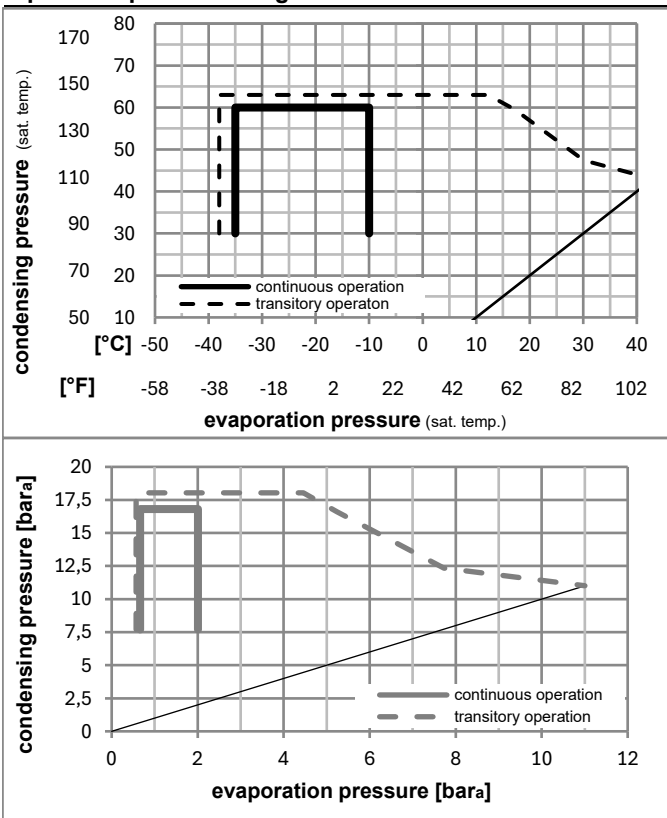

Components

a2	assy. relay + ext. protector (MRP39AIL-6)	117U4113
b	plastic cover	117U1021
d/dc	cord relief	117U0349

Model

Designation	TFS4.5FT	115-127V/60Hz	Conf. 2	Sales code:	102G3451
-------------	-----------------	----------------------	----------------	-------------	-----------------

Optimization + standard conditions

R134a, 115V/60Hz, RSIR, static, UL

		Evaporating pressure (saturation temperature)				Condensing pressure (saturation temperature)			Return gas temp.		Liquid temp.		Cooling capacity			COP	EER	Power consumption			
		pe	pc	RGT	Tliq	[W]	[Btu/h]	[kcal/h]	[W/W]	[Btu/Wh]	[kcal/Wh]	P1	I	m							
[°C]	[°F]	[°C]	[°F]	[°C]	[°F]							[W]	[A]	[kg/h]							
-23	-10	54	130	32	90	139,8	477	120,3	1,10	3,76	0,95	127,1	2,02	2,71						ASHRAE LBP	
-25	-13	55	131	32	90	102,0	348	87,8	0,84	2,88	0,73	121,0	1,99	2,44						cecomaf LBP	
-35	-31	40	104	20	68	82,3	281	70,8	0,88	3,01	0,76	93,5	1,87	1,81						EN12900 LBP	
-23	-10	49	120	4,4	40	118,4	404	101,9	0,93	3,19	0,80	126,9	2,01	3,13						ARI540 LBP	
-23	-10	41	105	32	90	165,1	564	142,1	1,32	4,50	1,13	125,3	1,99	3,20						AHAM LBP	
-35	-31	45	113	32	90	75,0	256	64,5	0,81	2,78	0,70	92,1	1,87	1,62						opt	

Performance tables

R134a, 115V/60Hz, RSIR, static, UL

	pe		Cooling capacity			COP	EER		P1	I	m
	[°C]	[°F]	[W]	[Btu/h]	[kcal/h]	[W/W]	[Btu/Wh]	[kcal/Wh]	[W]	[A]	[kg/h]
[°C / °F]	-35	-31	75,0	256	64,5	0,81	2,78	0,70	92,1	1,87	1,62
cond. pressure	-29	-20	104,3	356	89,7	0,96	3,27	0,82	108,9	1,93	2,26
pc= 45/113	-26	-15	121,4	415	104,5	1,03	3,53	0,89	117,4	1,96	2,63
return gas temp.	-23	-10	141,0	481	121,3	1,12	3,81	0,96	126,3	2,00	3,06
RGT= 32/90	-21	-5	162,9	556	140,2	1,20	4,10	1,03	135,7	2,05	3,54
liquid temp	-15	5	214,2	732	184,4	1,37	4,69	1,18	156,0	2,16	4,67
Tliq= 45/113	-10	14	268,9	918	231,4	1,53	5,22	1,31	176,1	2,28	5,88
[°C / °F]	-35	-31	56,0	191	48,2	0,64	2,17	0,55	88,0	1,87	1,33
cond. pressure	-29	-20	80,4	275	69,2	0,75	2,55	0,64	107,5	1,94	1,92
pc= 55/131	-26	-15	95,3	326	82,1	0,81	2,78	0,70	117,1	1,98	2,28
return gas temp	-23	-10	112,8	385	97,0	0,89	3,03	0,76	127,1	2,02	2,70
RGT= 32/90	-21	-5	132,7	453	114,2	0,96	3,29	0,83	137,6	2,07	3,18
liquid temp	-15	5	179,9	614	154,8	1,12	3,84	0,97	160,1	2,18	4,33
Tliq= 55/131	-10	14	231,1	789	198,9	1,27	4,34	1,09	181,9	2,31	5,59