

Model

Designation	TL2.5F	115V/60Hz 1~	Sales code:	102G3207
-------------	---------------	--------------	-------------	-----------------

Compressor design

Oil type	Polyolester	Refrigerant(s)	R134a, R513A, 0
Oil viscosity	15cST	Displacement	2,61cm ³ / 0,16cu.in
Oil quantity	184cm ³ / 6,2fl.oz	Compressors on pallet	125
Refr. charge - tech. limit	400g / 14,1oz		
Free gas volume comp.	1600cm ³ / 54,1fl.oz		
Weight	6,7kg / 14,8lbs		
Motor protection	1# internal		
Winding resistance main	7,33Ω (at 25°C)		
Winding resistance aux	4,78Ω (at 25°C)		
Max. winding temp.	125°C / 257°F		
Max. discharge temp.	130°C / 266°F		



General - Configurations with TL2.5F

	Conf. 1
Motorconfiguration	RSIR
Power supply (nominal)	115V/60Hz
Number of phases	1
Voltage range	103-127V
Approvals	UL
Starting torque	LST
Note	- / -

Applications with TL2.5F

	Conf. 1
Refrigerant	R134a
Application	LBP+MBP
System cooling	static
Hot gas defrost	OK
Long interval pull down	- / -

Electrical data - Configurations with TL2.5F

	Conf. 1
Starting device type	PTC
Run capacitor	- / -
Start capacitor	- / -
LRA (locked rotor amps / 4s)	5,3A
RLA (rated load amps / 1s)	
Cut in current	14,5A

Model

Designation

TL2.5F

115V/60Hz 1~

Sales code:

102G3207

Compressor dimensions

Housing	A Height	174mm / 6,85in
	B Height	168mm / 6,61in
	C Length shell	176mm / 6,93in
	D Length w. cover	222mm / 8,74in
	E Width	157mm / 6,18in

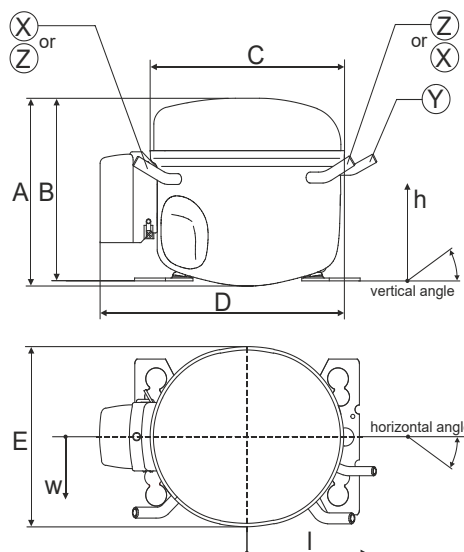

Connectors		Suction	Discharge	Process
		X	Y	Z
Diameter	[mm]	øi 6,41-6,59	øi 5,12-5,22	øi 6,41-6,59
	(i:inside, o:outside) [in]	øi 0,25-0,26	øi 0,2-0,21	øi 0,25-0,26
Material		steel/CU	steel/CU	steel/CU
Horizontal angle	±2°	0°	0°	0°
Vertical angle	±2°	31,5°	28°	150°
Position l/h/w	[mm]	96/105/71	117/107/29	-102/105/66
	[in]	3,8/4,1/2,8	4,6/4,2/1,1	-4/4,1/2,6
Straight tube l.	[mm]	12	12	12
	[in]	0,5	0,5	0,5

Compressor fixation

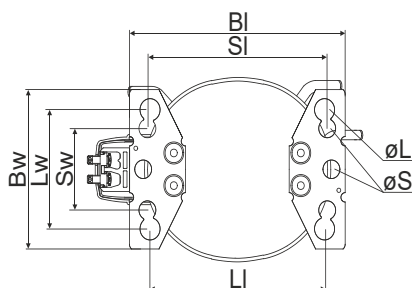

Baseplate	[mm]	[inch]
BI	204	8.03
Bw	136	5.35
Large holes		
LI	165	6.5
Lw	101.6	4
øL	ø 19	ø 0.75
Small holes		
SI	170	6.7
Sw	70	2.76
øS	ø 16	ø 0.63

Bolt joint

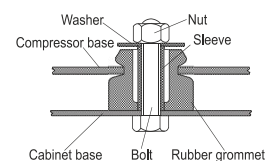

Snap-on

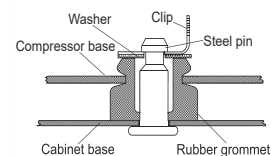

Mounting accessories	one comp.	multi pack
Bolt joint M6 ø16mm	118-1917	118-1918
Bolt joint ø1/4" ø16mm	118-1946	
Bolt joint ø1/4" ø19mm	118-1949	
Snap-on ø7,3 ø16mm	118-1947	118-1919

Application notes

Provision for PE Grounding is located at the PE Stamp on the compressor

Model

Designation	TL2.5F	115V/60Hz	Conf. 1	Sales code:	102G3207
-------------	---------------	------------------	----------------	-------------	-----------------

Configuration

Motorconfiguration	RSIR
Power supply (nominal)	115V/60Hz 1~
Refrigerant	R134a
Application	LBP+MBP
Voltage range	103-127V
Starting torque	LST
Approvals	UL

Electrical accessories / wiring diagram

RSIR

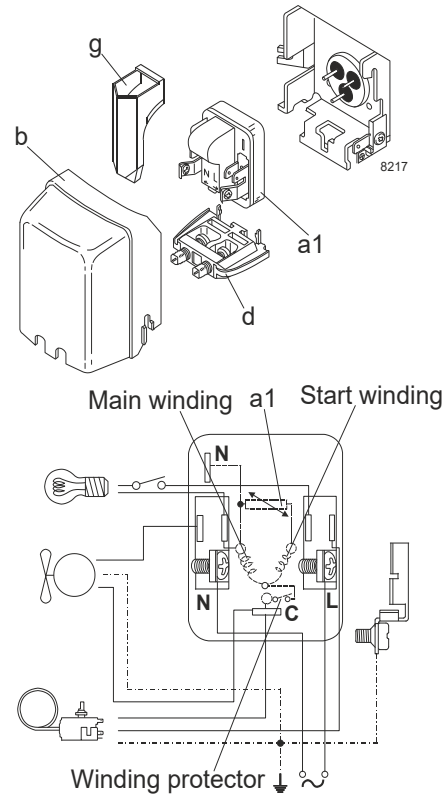

Ambient/ machine room temperatures minimum /maximum

Ambient temperature range:	10 - 43°C / 50 - 110°F
Machine room temperature range:	10 - 48°C / 50 - 119°F
Compressor cooling:	static

Operation pressure range

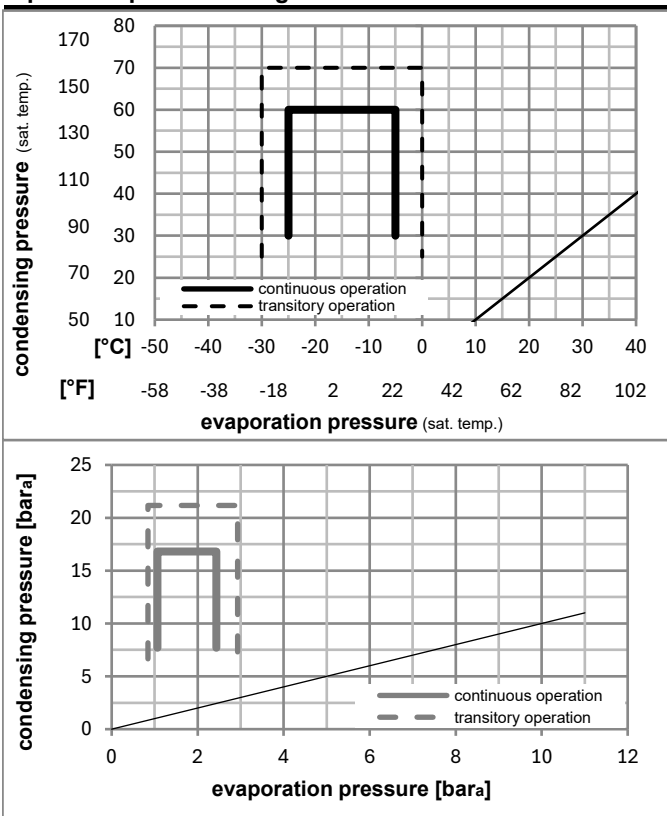

Components

a1	PTC starter (115V, 50hm, 6.3mm)	103N0026
b	plastic cover	103N2011
d	cord relief	103N1010
g	protection screen for PTC	103N0476

Alternative components

a1	PTC starter (115V, 50hm, 4.8mm)	103N0023
b	plastic cover	103N2011
d	cord relief	103N1010
g	protection screen for PTC	103N0476

Model

Designation	TL2.5F	115V/60Hz	Conf. 1	Sales code:	102G3207
-------------	---------------	------------------	----------------	-------------	-----------------

Optimization + standard conditions

R134a, 115V/60Hz, RSIR, static, UL

	Evaporating pressure (saturation temperature)				Condensing pressure (saturation temperature)			COP	EER	P1	Power consumption		Ref. mass flow	ASHRAE LBP
	pe	pc	RGT	Tliq	W	[Btu/h]	[kcal/h]				[W/W]	[Btu/Wh]		
[°C]	-23	54	32	32	59,3	202	51,0	0,91	3,12	0,79	65,0	0,94	1,15	ASHRAE LBP
[°F]	-10	130	90	90										
[°C]	-25	55	32	55	43,0	147	37,0	0,70	2,41	0,61	61,0	0,91	1,03	cecomaf LBP
[°F]	-13	131	90	131										
[°C]	-35	40	20	40	30,4	104	26,2	0,68	2,33	0,59	44,5	0,68	0,67	EN12900 LBP
[°F]	-31	104	68	104										
[°C]	-23	49	4,4	49	50,9	174	43,8	0,76	2,61	0,66	66,6	0,94	1,34	ARI540 LBP
[°F]	-10	120	40	120										
[°C]	-23	41	32	32	73,1	250	62,9	1,09	3,71	0,94	67,2	0,95	1,42	AHAM LBP
[°F]	-10	105	90	90										
[°C]	-35	45	32	45	28,9	99	24,9	0,69	2,35	0,59	42,0	0,65	0,62	opt
[°F]	-31	113	90	113										

Performance tables

R134a, 115V/60Hz, RSIR, static, UL

	pe		Cooling capacity			COP	EER	P1	I	m	
	[°C]	[°F]	[W]	[Btu/h]	[kcal/h]	[W/W]	[Btu/Wh]	[kcal/Wh]	[W]	[A]	[kg/h]
[°C / °F]	-25	-13	55,1	188	47,4	0,86	2,94	0,74	64,0	0,93	1,19
cond. pressure	-23	-10	61,4	210	52,9	0,92	3,13	0,79	67,1	0,95	1,33
pc= 45/113	-21	-5	73,3	250	63,0	1,02	3,47	0,88	72,0	0,98	1,59
return gas temp.	-18	0	86,5	296	74,5	1,12	3,84	0,97	76,9	1,00	1,88
RGT= 32/90	-15	5	101,2	346	87,1	1,23	4,21	1,06	82,0	1,03	2,21
liquid temp	-9	15	134,5	459	115,7	1,44	4,93	1,24	93,2	1,12	2,94
Tliq= 45/113	-5	23	164,7	562	141,7	1,58	5,41	1,36	104,0	1,25	3,62
[°C / °F]	-25	-13	43,0	147	37,0	0,70	2,41	0,61	61,0	0,91	1,03
cond. pressure	-23	-10	47,8	163	41,1	0,74	2,52	0,64	64,7	0,94	1,14
pc= 55/131	-21	-5	57,1	195	49,1	0,81	2,75	0,69	70,8	0,97	1,37
return gas temp	-18	0	67,8	232	58,3	0,88	3,01	0,76	76,8	1,00	1,63
RGT= 32/90	-15	5	79,9	273	68,8	0,96	3,29	0,83	83,0	1,04	1,92
liquid temp	-9	15	108,1	369	93,0	1,12	3,83	0,96	96,4	1,14	2,61
Tliq= 55/131	-5	23	134,2	458	115,5	1,23	4,20	1,06	109,0	1,29	3,26