

## Model

Designation **CU NLE12.6MN R290 230/1/50 CAP**



Sales code: 314H5003

Engineering code: CUNLE126MNCE

## Application Data

Power supply 220-240V / 50Hz 1~  
 Refrigerants R290  
 Refr. charge - tech. limit 150g / 5,3oz  
 Starter HST / capillary tube or expansion valve  
 Sound pressure (10m) 31,9dB(A)

## Generic data

Voltage range 198 - 254V / 50Hz  
 Refrigerant R290  
 Application MBP  
  
 Rated performance pe=-10°C, Tsuc=20°C, Tamb=25°C, subccoling: 0K  
 Cooling capacity 944W / 3224Btu/h  
 Power consumption 493,8W  
 Current consumption 2,9A  
 COP/EER 1,91 / 6,53Btu/Wh  
  
 Approvals Eco design (EU) 2015/1095,  
 CE, UK CA, VDE

## Compressor

Designation **NLE12.6MN**  
 Motor configuration CSIR  
 Locked rotor amperage 15,6A  
 Rated load amperage 2,7A  
 Winding resistance main 5Ω  
 Winding resistance aux 9,9Ω  
 Oil quantity 300cm<sup>3</sup> / 10,1fl.oz  
 Oil type POE  
 Horsepower rating 3/5 HP

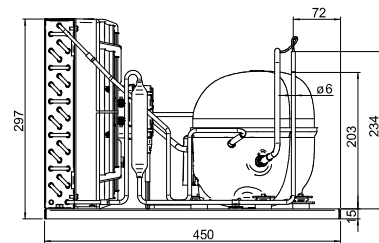

## Dimensions

### Condensing unit

Height x Width x Depth 297 x 350 x 450 [mm] / 11,7 x 13,8 x 17,7 [in]  
 Weight 19,6kg / 43,2lbs  
 Suction adapter OD ø8mm / 1/3in  
 Discharge adapter OD ø6mm / 1/4in  
 Process connector ø6,2mm / 0,24in

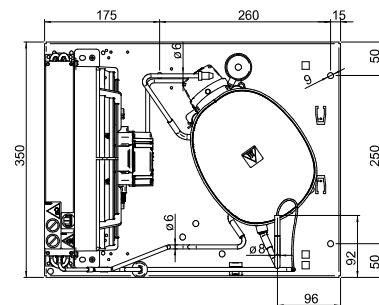

### Package data

Height x Width x Depth 340 x 372 x 570 [mm] / 13,4 x 14,6 x 22,4 [in]  
 Weight 22,6kg / 49,8lbs

## Model

Designation **CU NLE12.6MN R290 230/1/50 CAP**

Sales code: 314H5003

Engineering code: CUNLE126MNCE

## Components Condensing-Unit / Spare Parts

Component	Type	Spare part code number
Compressor code	NLE12.6MN	105H6377
Condenser	Condenser (3 rows x 11 tubes)	314S0010
Fan motor	30W	314S0016
Blade code	ø254mm 22°	314S0026
Air flow	551,4m³/h	
Receiver code	not installed	-/-
Suction valve code	OD ø8mm / 1/3in	-/-
Liquid valve code	OD ø6mm / 1/4in	-/-

Compressor starting equipment	Spare part code number
pos. a2 - relay	117U7011
pos. c - start capacitor (80µF)	117U5015
pos. b - plastic cover	103N2010
pos. d - cord relief	103N1010

## Wiring Sketch Compressor

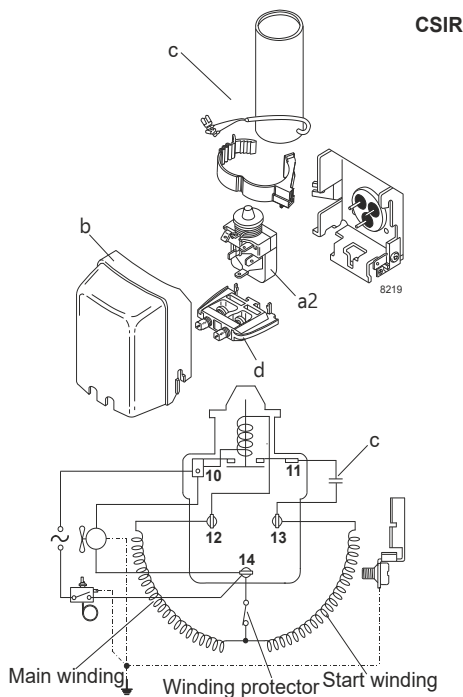

## Model

Designation	<b>CU NLE12.6MN R290 230/1/50 CAP</b>	Sales code:	314H5003
		Engineering code:	CUNLE126MNCE

## Cooling performance - Conf. 1

Power supply	220-240V / 50Hz 1~	Voltage range	198 - 254V / 50Hz
Refr. charge - tech. limit	150g / 5,3oz		
Starter	HST / capillary tube or expansion valve		
Motor configuration	CSIR		
Refrigerant	R290		
Application	MBP		
Approvals	Eco design (EU) 2015/1095, CE, UK CA, VDE		

ambient temperature	[°C / °F]	25 / 77							(suction gas temperature [°C / °F]: 20 / 68, subcooling: 0K)
evaporating temperature	[°C / °F]	-25 / -13	-20 / -4	-15 / 5	-10 / 14	0 / 32	5 / 41	10 / 50	
cooling capacity	[W]	572	685	810	944	1230	1376	1520	
COP	[W/W]	1,56	1,69	1,81	1,91	2,02	2,01	1,96	
cooling capacity	[Btu/h]	1953	2339	2766	3224	4201	4700	5192	
power consumption	[W]	367	406	448	494	609	685	776	
current consumption	[A]	2,5	2,6	2,8	2,9	3,4	3,7	4,2	

ambient temperature	[°C / °F]	32 / 90							(suction gas temperature [°C / °F]: 20 / 68, subcooling: 0K)
evaporating temperature	[°C / °F]	-25 / -13	-20 / -4	-15 / 5	-10 / 14	0 / 32	5 / 41	10 / 50	
cooling capacity	[W]	522	622	734	855	1111	1243	1372	
COP	[W/W]	1,37	1,47	1,57	1,64	1,7	1,68	1,62	
cooling capacity	[Btu/h]	1781	2126	2508	2919	3795	4244	4684	
power consumption	[W]	380	422	468	521	655	741	845	
current consumption	[A]	2,6	2,7	2,9	3,1	3,6	4	4,5	

ambient temperature	[°C / °F]	38 / 100							(suction gas temperature [°C / °F]: 20 / 68, subcooling: 0K)
evaporating temperature	[°C / °F]	-25 / -13	-20 / -4	-15 / 5	-10 / 14	0 / 32			
cooling capacity	[W]	475	567	669	780	1015			
COP	[W/W]	1,21	1,3	1,37	1,43	1,46			
cooling capacity	[Btu/h]	1621	1937	2286	2663	3468			
power consumption	[W]	393	437	487	545	694			
current consumption	[A]	2,6	2,8	3	3,2	3,8			

ambient temperature	[°C / °F]	43 / 109							(suction gas temperature [°C / °F]: 20 / 68, subcooling: 0K)
evaporating temperature	[°C / °F]	-25 / -13	-20 / -4	-15 / 5	-10 / 14				
cooling capacity	[W]	436	523	619	722				
COP	[W/W]	1,08	1,17	1,23	1,28				
cooling capacity	[Btu/h]	1489	1786	2113	2465				
power consumption	[W]	402	448	502	564				
current consumption	[A]	2,6	2,8	3	3,2				