

**Model**

Designation	<b>DLE4CNT</b>	<b>220-240V/50Hz 1~</b>	Sales code:	<b>102H4460</b>
-------------	----------------	-------------------------	-------------	-----------------

**Compressor design**

Oil type	Polyolester	Refrigerant(s)	<b>R290</b>
Oil viscosity	32cSt	Displacement	4cm <sup>3</sup> / 0,24cu.in
Oil quantity	221cm <sup>3</sup> / 7,5fl.oz	Compressors on pallet	100
Refr. charge - tech. limit	150g / 5,3oz		
Free gas volume comp.	1390cm <sup>3</sup> / 47fl.oz		
Weight	8,15kg / 18lbs		
Motor protection	1# internal		
Winding resistance main	20,3Ω (at 25°C)		
Winding resistance aux	11,7Ω (at 25°C)		
Max. winding temp.	125°C / 257°F		
Max. discharge temp.	120°C / 248°F		



**General - Configurations with DLE4CNT**

	<b>Conf. 1</b>	<b>Conf. 2</b>	<b>Conf. 3</b>
Motorconfiguration	CSIR	RSIR	RSCR
Power supply (nominal)	220-240V/50Hz	220-240V/50Hz	220-240V/50Hz
Number of phases	1	1	1
Voltage range	187-254V	187-254V	187-254V
Approvals			
Starting torque	HST	LST	LST
Note	- / -		

**Applications with DLE4CNT**

	<b>Conf. 1</b>	<b>Conf. 2</b>	<b>Conf. 3</b>
Refrigerant	R290	R290	R290
Application	LBP+MBP	LBP+MBP	LBP+MBP
System cooling	fan 3m/s	fan 3m/s	fan 3m/s
Hot gas defrost	OK	OK	OK
Long interval pull down	OK	OK	OK

**Electrical data - Configurations with DLE4CNT**

	<b>Conf. 1</b>	<b>Conf. 2</b>	<b>Conf. 3</b>
Starting device type	relay	PTC	PTC
Run capacitor	-/-	-/-	5μF
Start capacitor	60μF	-/-	-/-
LRA (locked rotor amps / 4s)	5,4A	5A	5A
RLA (rated load amps / 1s)	1,04A	1,04A	0,85A
Cut in current	5,4A	9,9A	9,9A
IP class	21	21	21

**Model**

Designation	<b>DLE4CNT</b>	<b>220-240V/50Hz 1~</b>	Sales code:	<b>102H4460</b>
-------------	----------------	-------------------------	-------------	-----------------

**Compressor dimensions**

<b>Housing</b>	A Height	174mm / 6,85in
	B Height	168mm / 6,61in
	C Length shell	183mm / 7,2in
	D Length w. cover	232mm / 9,13in
	E Width	156mm / 6,14in

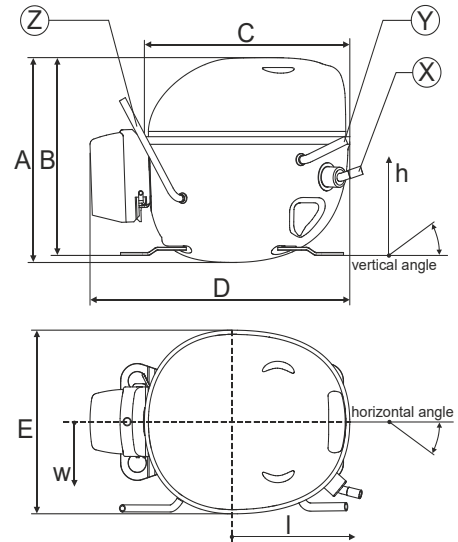

Connectors		Suction	Discharge	Process
		X	Y	Z
Diameter	[mm]	øi 6,11-6,29	øi 5,12-5,22	øi 6,1-6,3
	(i:inside, o:outside) [in]	øi 0,24-0,25	øi 0,2-0,21	øi 0,24-0,25
Material		copper	copper	copper
Horizontal angle	±2°	10°	0°	0°
Vertical angle	±2°	18°	25°	119°
Position l/h/w	[mm]	127/74/66	98/96/72	-98/133/73
	[in]	5/2,9/2,6	3,8/3,8/2,8	-3,9/5,2/2,9
Straight tube l.	[mm]	12	12	12
	[in]	0,5	0,5	0,5

**Compressor fixation**

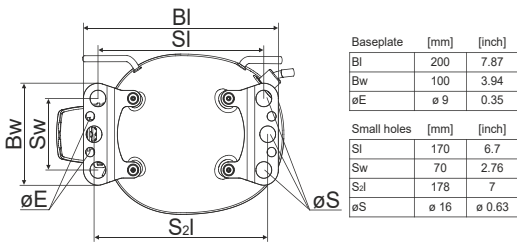

**Bolt joint**

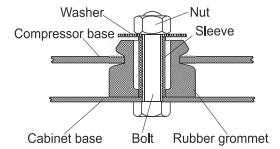

**Snap-on**

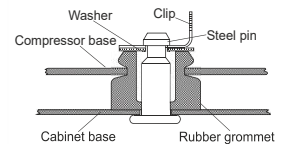

Mounting accessories	one comp.	multi pack
Bolt joint   M6   ø16mm	118-1917	118-1918
Bolt joint   ø1/4"   ø16mm	118-1946	
Snap-on   ø7,3   ø16mm	118-1947	118-1919

**Model**

Designation	<b>DLE4CNT</b>	<b>220-240V/50Hz</b>	<b>Conf. 1</b>	Sales code:	<b>102H4460</b>
-------------	----------------	----------------------	----------------	-------------	-----------------

**Configuration**

Motorconfiguration	CSIR
Power supply (nominal)	220-240V/50Hz 1~
Refrigerant	R290
Application	LBP+MBP
Voltage range	187-254V
Starting torque	HST
Approvals	

**Electrical accessories / wiring diagram**

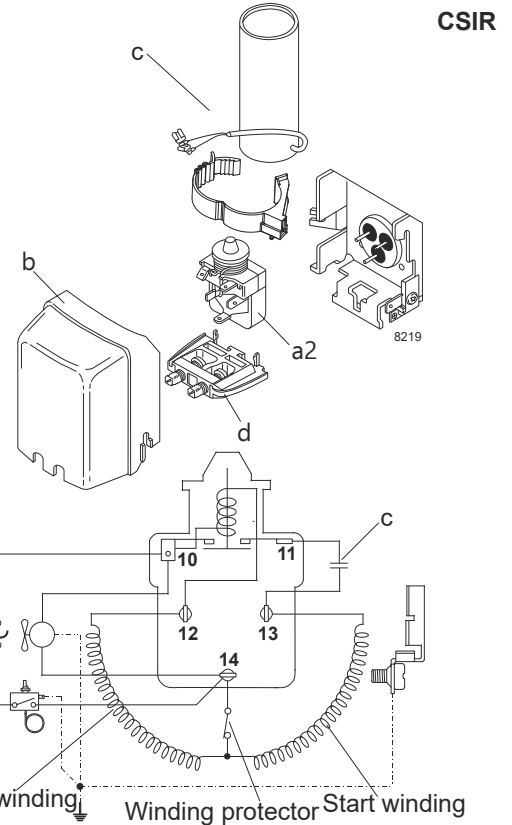

**Ambient temperatures / system cooling**

Ambient temperature min.:	10°C / 50°F
Ambient temperature max.:	43°C / 110°F

System cooling (n/a: outside limits)			
T ambient	LBP	MBP	HBP
32°C / 90°F	fan 3m/s	fan 3m/s	n/a
38°C / 100°F	fan 3m/s	fan 3m/s	n/a
43°C / 110°F	fan 3m/s	fan 3m/s	n/a

**Operation pressure range**

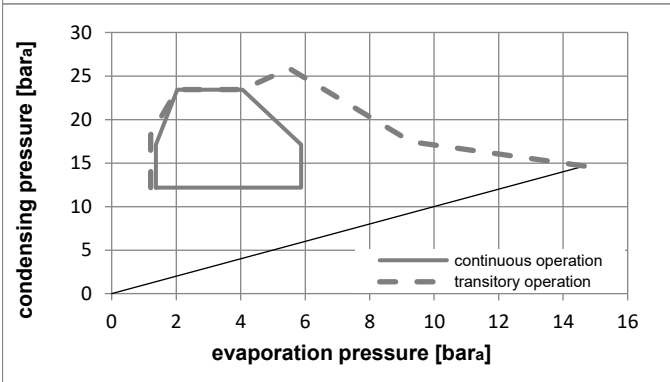
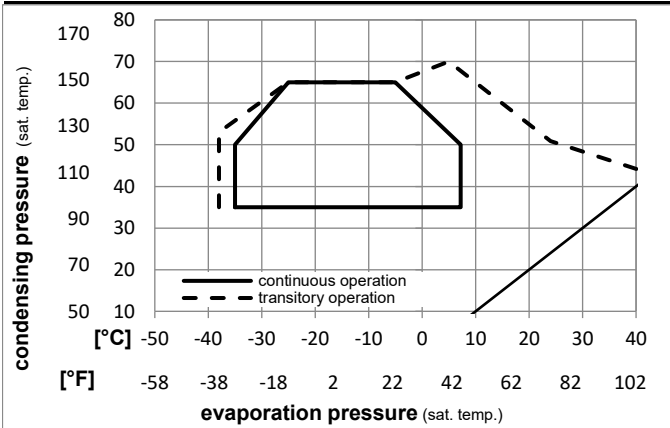

**Components**

a2	assy. relay	117U7000
c	start capacitor (60μF)	117U5014
b	plastic cover	103N0491
d	cord relief	103N1010

**Model**

Designation **DLE4CNT 220-240V/50Hz** Conf. 1 Sales code: **102H4460**

**Optimization + standard conditions**

220-240V/50Hz 1~, CSIR, fan 3m/s,

		Evaporating pressure (saturation temperature)				Condensing pressure (saturation temperature)						Power consumption			
		Return gas temp.				Liquid temp.						Current consumption		Ref. mass flow	
		Cooling capacity				COP		EER		P1	I	m			
	pe	pc	RGT	Tliq	[W]	[Btu/h]	[kcal/h]	[W/W]	[Btu/Wh]	[kcal/Wh]	[W]	[A]	[kg/h]		
[°C]	-23,3	54,4	32,2	32,2	190,2	650	163,7	1,47	5,03	1,27	129,1	0,84	1,93	ASHRAE LBP	
[°F]	-10	130	90	90											
[°C]	-25	55	32	55	141,8	484	122,0	1,14	3,88	0,98	124,9	0,82	1,77	cecomaf LBP	
[°F]	-13	131	89,6	131											
[°C]	-35	40	20	40	107,3	366	92,3	1,14	3,90	0,98	94,0	0,74	1,23	EN12900 LBP	
[°F]	-31	104	68	104											
[°C]	-6,66	54,4	35	46,1	338,4	1156	291,3	1,97	6,73	1,70	171,8	0,99	3,86	ASHRAE MBP	
[°F]	20	130	95	115											
[°C]	-10	55	32	55	270,9	925	233,2	1,64	5,61	1,41	164,8	0,96	3,43	cecomaf MBP	
[°F]	14	131	89,6	131											
[°C]	-10	45	20	45	303,4	1036	261,1	2,04	6,95	1,75	149,0	0,91	3,73	EN12900 MBP	
[°F]	14	113	68	113											

**Performance tables**

220-240V/50Hz 1~, CSIR, fan 3m/s,

	pe	Cooling capacity			COP		EER		P1	I	m		
	[°C]	[°F]	[W]	[Btu/h]	[kcal/h]	[W/W]	[Btu/Wh]	[kcal/Wh]	[W]	[A]	[kg/h]		
[°C / °F]	-35	-31	101,0	345	86,9	1,06	3,61	0,91	95,5	0,74	1,13		
cond. pressure	-25	-13	167,7	573	144,3	1,42	4,86	1,23	117,8	0,80	1,89		
pc= 45/113	-15	5	261,0	891	224,6	1,87	6,40	1,61	139,4	0,87	2,97		
return gas temp.	-10	14	315,8	1079	271,8	2,12	7,24	1,82	149,0	0,91	3,61		
RGT= 32/90	-5	23	375,2	1282	322,9	2,38	8,14	2,05	157,3	0,94	4,32		
liquid temp	0	32	438,5	1497	377,3	2,67	9,13	2,30	164,1	0,97	5,09		
Tliq= 45/113	7,2	45	534,8	1826	460,3	3,14	10,73	2,70	170,2	1,01	6,28		
[°C / °F]	-35	-31	83,6	285	71,9	0,86	2,92	0,74	97,6	0,74	1,03		
cond. pressure	-25	-13	141,8	484	122,0	1,14	3,88	0,98	124,9	0,82	1,77		
pc= 55/131	-15	5	223,3	762	192,1	1,47	5,01	1,26	152,1	0,92	2,81		
return gas temp	-10	14	270,9	925	233,2	1,64	5,61	1,41	164,8	0,96	3,43		
RGT= 32/90	-5	23	322,3	1101	277,4	1,83	6,24	1,57	176,5	1,00	4,11		
liquid temp	0	32	376,7	1286	324,2	2,02	6,89	1,74	186,7	1,04	4,84		
Tliq= 55/131	7,2	45	458,8	1567	394,9	2,31	7,90	1,99	198,2	1,09	5,98		

**Model**

Designation	<b>DLE4CNT</b>	<b>220-240V/50Hz</b>	<b>Conf. 2</b>	Sales code:	<b>102H4460</b>
-------------	----------------	----------------------	----------------	-------------	-----------------

**Configuration**

Motorconfiguration	RSIR
Power supply (nominal)	220-240V/50Hz 1~
Refrigerant	R290
Application	LBP+MBP
Voltage range	187-254V
Starting torque	LST
Approvals	

**Electrical accessories / wiring diagram**

RSIR

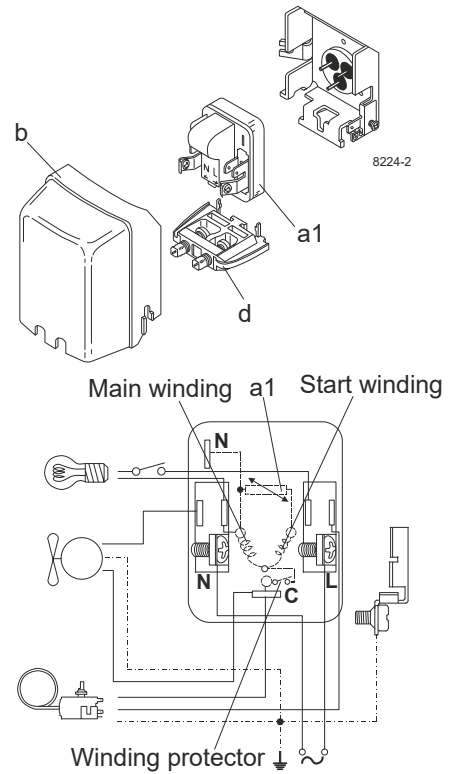

**Ambient temperatures / system cooling**

Ambient temperature min.:	10°C / 50°F
Ambient temperature max.:	43°C / 110°F

System cooling (n/a: outside limits)			
T ambient	LBP	MBP	HBP
32°C / 90°F	fan 3m/s	fan 3m/s	n/a
38°C / 100°F	fan 3m/s	fan 3m/s	n/a
43°C / 110°F	fan 3m/s	fan 3m/s	n/a

**Operation pressure range**

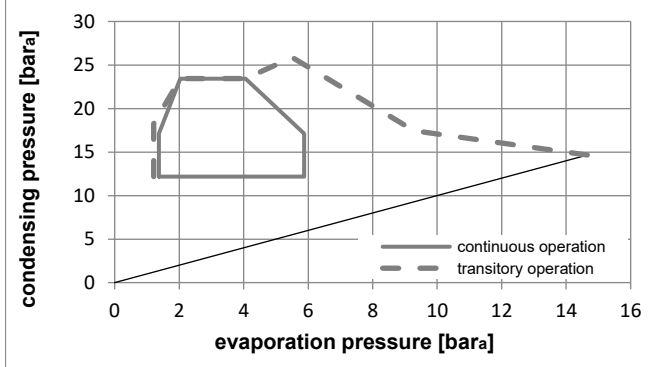
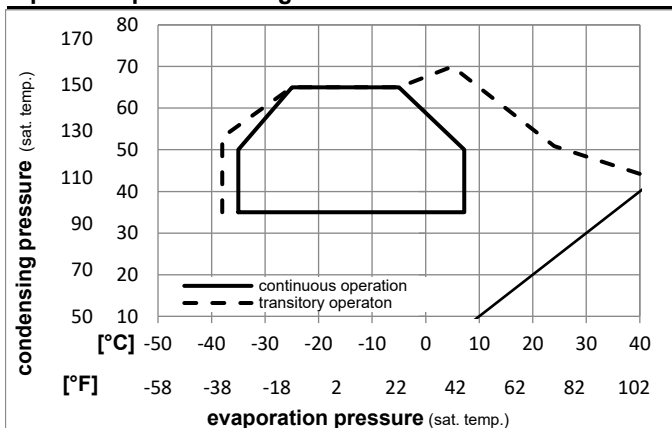

**Components**

a1	e-PTC starter (220V, 250hm, 4.8mm)	103N0050
b	plastic cover	103N0491
d	cord relief	103N1010

**Model**

Designation	<b>DLE4CNT</b>	<b>220-240V/50Hz</b>	<b>Conf. 2</b>	Sales code:	<b>102H4460</b>
-------------	----------------	----------------------	----------------	-------------	-----------------

**Optimization + standard conditions**

220-240V/50Hz 1~, RSIR, fan 3m/s,

Evaporating pressure (saturation temperature)		Condensing pressure (saturation temperature)				Cooling capacity				COP		EER		Power consumption		ASHRAE LBP
pe		pc		RGT	Tliq		[W]	[Btu/h]	[kcal/h]	[W/W]	[Btu/Wh]	[kcal/Wh]	P1	I	Ref. mass flow	
[°C]	[°F]	[°C]	[°F]	[°C]	[°C]	[°F]	[W]	[Btu/h]	[kcal/h]	[W/W]	[Btu/Wh]	[kcal/Wh]	[W]	[A]	[kg/h]	
-23,3	54,4	32,2	32,2	190,2	650	163,7	1,47	5,03	1,27	129,1	0,84	1,93				
-10	130	90	90													
-25	55	32	55	141,8	484	122,0	1,14	3,88	0,98	124,9	0,82	1,77				cecomaf LBP
-13	131	89,6	131													
-35	40	20	40	107,3	366	92,3	1,14	3,90	0,98	94,0	0,74	1,23				EN12900 LBP
-31	104	68	104													
-6,66	54,4	35	46,1	338,4	1156	291,3	1,97	6,73	1,70	171,8	0,99	3,86				ASHRAE MBP
20	130	95	115													
-10	55	32	55	270,9	925	233,2	1,64	5,61	1,41	164,8	0,96	3,43				cecomaf MBP
14	131	89,6	131													
-10	45	20	45	303,4	1036	261,1	2,04	6,95	1,75	149,0	0,91	3,73				EN12900 MBP
14	113	68	113													

**Performance tables**

220-240V/50Hz 1~, RSIR, fan 3m/s,

[°C / °F]	pe	Cooling capacity			COP			EER			P1	I	m
	[°C]	[°F]	[W]	[Btu/h]	[kcal/h]	[W/W]	[Btu/Wh]	[kcal/Wh]	[W]	[A]	[kg/h]		
-35	-31	101,0	345	86,9	1,06	3,61	0,91	95,5	0,74	1,13			
cond. pressure	-25	-13	167,7	573	144,3	1,42	4,86	1,23	117,8	0,80	1,89		
pc= 45/113	-15	5	261,0	891	224,6	1,87	6,40	1,61	139,4	0,87	2,97		
return gas temp.	-10	14	315,8	1079	271,8	2,12	7,24	1,82	149,0	0,91	3,61		
RGT= 32/90	-5	23	375,2	1282	322,9	2,38	8,14	2,05	157,3	0,94	4,32		
liquid temp	0	32	438,5	1497	377,3	2,67	9,13	2,30	164,1	0,97	5,09		
Tliq= 45/113	7,2	45	534,8	1826	460,3	3,14	10,73	2,70	170,2	1,01	6,28		
-35	-31	83,6	285	71,9	0,86	2,92	0,74	97,6	0,74	1,03			
cond. pressure	-25	-13	141,8	484	122,0	1,14	3,88	0,98	124,9	0,82	1,77		
pc= 55/131	-15	5	223,3	762	192,1	1,47	5,01	1,26	152,1	0,92	2,81		
return gas temp	-10	14	270,9	925	233,2	1,64	5,61	1,41	164,8	0,96	3,43		
RGT= 32/90	-5	23	322,3	1101	277,4	1,83	6,24	1,57	176,5	1,00	4,11		
liquid temp	0	32	376,7	1286	324,2	2,02	6,89	1,74	186,7	1,04	4,84		
Tliq= 55/131	7,2	45	458,8	1567	394,9	2,31	7,90	1,99	198,2	1,09	5,98		

**Model**

Designation	<b>DLE4CNT</b>	<b>220-240V/50Hz</b>	<b>Conf. 3</b>	Sales code:	<b>102H4460</b>
-------------	----------------	----------------------	----------------	-------------	-----------------

**Configuration**

Motorconfiguration	RSCR
Power supply (nominal)	220-240V/50Hz 1~
Refrigerant	R290
Application	LBP+MBP
Voltage range	187-254V
Starting torque	LST
Approvals	

**Electrical accessories / wiring diagram**

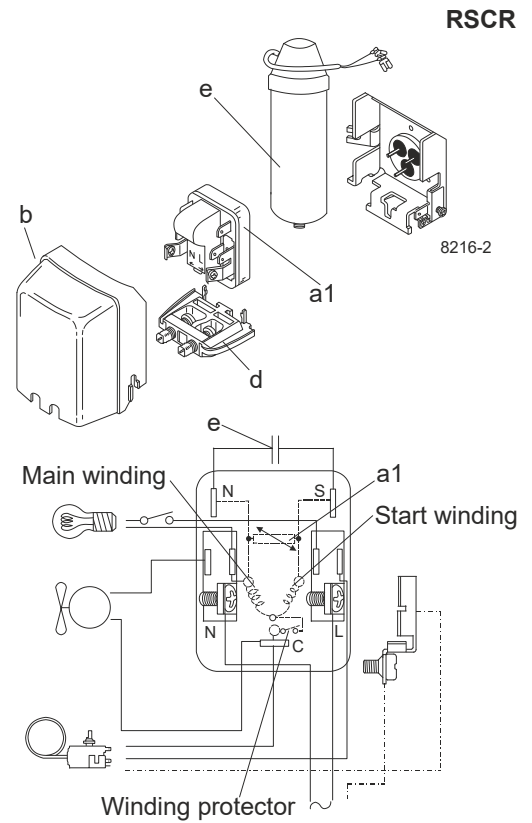

**Ambient temperatures / system cooling**

Ambient temperature min.:	10°C / 50°F
Ambient temperature max.:	43°C / 110°F

System cooling (n/a: outside limits)			
T ambient	LBP	MBP	HBP
32°C / 90°F	fan 3m/s	fan 3m/s	n/a
38°C / 100°F	fan 3m/s	fan 3m/s	n/a
43°C / 110°F	fan 3m/s	fan 3m/s	n/a

**Operation pressure range**

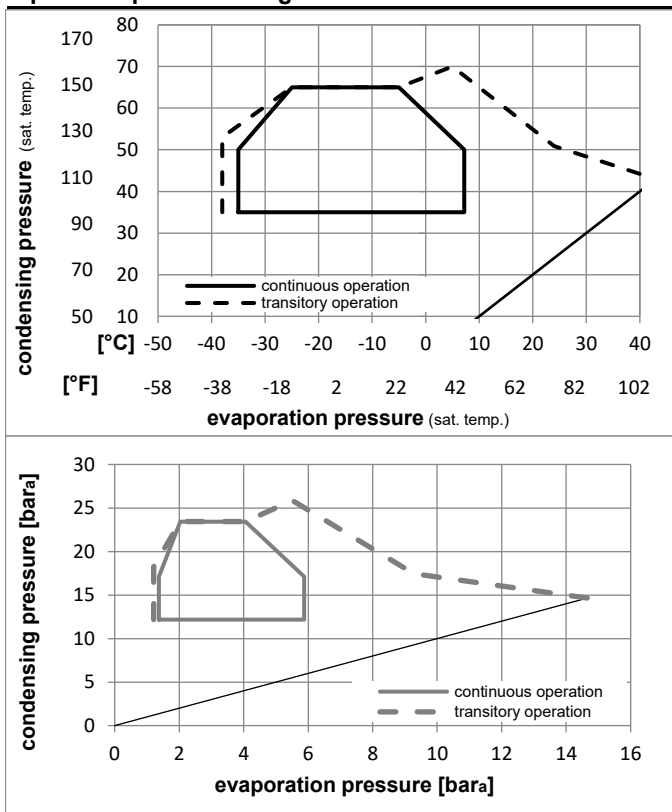

**Components**

a1	e-PTC starter (220V, 250hm, 4.8mm)	103N0050
e	run capacitor (5μF, 4.8mm)	117-7129
b	plastic cover	103N0491
d	cord relief	103N1010
	bracket for run capacitor	117-0300
	screw M4x8mm	117-0301

**Model**

Designation **DLE4CNT 220-240V/50Hz** Conf. **3** Sales code: **102H4460**

**Optimization + standard conditions**

220-240V/50Hz 1~, RSCR, fan 3m/s,

	Evaporating pressure (saturation temperature)				Condensing pressure (saturation temperature)						Power consumption			ASHRAE LBP
	pe	pc	RGT	Tliq	Cooling capacity			COP	EER	P1	I	Ref. mass flow		
	[°C]	[°C]	[°C]	[°C]	[W]	[Btu/h]	[kcal/h]	[W/W]	[Btu/Wh]	[kcal/Wh]	[W]	[A]	[kg/h]	
	-23,3	54,4	32,2	32,2	192,1	656	165,4	1,58	5,38	1,36	122,0	0,80	1,95	ASHRAE LBP
	[-10]	130	90	90										
	-25	55	32	55	143,2	489	123,3	1,21	4,14	1,04	118,1	0,78	1,78	cecomaf LBP
	[-13]	131	89,6	131										
	-35	40	20	40	108,3	370	93,2	1,21	4,14	1,04	89,4	0,70	1,24	EN12900 LBP
	[-31]	104	68	104										
	-6,66	54,4	35	46,1	341,8	1167	294,2	2,15	7,33	1,85	159,2	0,90	3,90	ASHRAE MBP
	[20]	130	95	115										
	-10	55	32	55	273,6	935	235,5	1,78	6,09	1,53	153,4	0,89	3,46	cecomaf MBP
	[14]	131	89,6	131										
	-10	45	20	45	306,4	1047	263,7	2,19	7,49	1,89	139,6	0,85	3,76	EN12900 MBP
	[14]	113	68	113										

**Performance tables**

220-240V/50Hz 1~, RSCR, fan 3m/s,

	pe	Cooling capacity			COP	EER	P1	I	m		
	[°C]	[°F]	[W]	[Btu/h]	[kcal/h]	[W/W]	[Btu/Wh]	[kcal/Wh]	[W]	[A]	[kg/h]
[°C / °F]	-35	-31	102,0	348	87,8	1,12	3,84	0,97	90,7	0,70	1,14
cond. pressure	-25	-13	169,4	578	145,8	1,52	5,18	1,31	111,6	0,76	1,91
pc= 45/113	-15	5	263,6	900	226,9	2,01	6,86	1,73	131,2	0,83	3,00
return gas temp.	-10	14	319,0	1089	274,5	2,28	7,80	1,97	139,6	0,85	3,65
RGT= 32/90	-5	23	379,0	1294	326,2	2,59	8,83	2,23	146,5	0,85	4,36
liquid temp	0	32	442,8	1512	381,1	2,92	9,98	2,51	151,6	0,82	5,14
Tliq= 45/113	7,2	45	540,2	1845	464,9	3,49	11,92	3,00	154,8	0,73	6,35
[°C / °F]	-35	-31	84,4	288	72,7	0,91	3,10	0,78	93,0	0,70	1,04
cond. pressure	-25	-13	143,2	489	123,3	1,21	4,14	1,04	118,1	0,78	1,78
pc= 55/131	-15	5	225,5	770	194,1	1,58	5,40	1,36	142,5	0,87	2,83
return gas temp	-10	14	273,6	935	235,5	1,78	6,09	1,53	153,4	0,89	3,46
RGT= 32/90	-5	23	325,5	1112	280,2	2,00	6,82	1,72	163,0	0,90	4,15
liquid temp	0	32	380,5	1299	327,4	2,23	7,60	1,92	170,9	0,88	4,89
Tliq= 55/131	7,2	45	463,4	1583	398,8	2,60	8,87	2,24	178,4	0,80	6,04