

Model

Designation	DLE4.8CN	115-127V/60Hz 1~	Sales code:	102H3583
-------------	-----------------	-------------------------	-------------	-----------------

Compressor design

Oil type	Polyolester	Refrigerant(s)	R290
Oil viscosity	32cSt	Displacement	4,8cm ³ / 0,29cu.in
Oil quantity	221cm ³ / 7,5fl.oz	Compressors on pallet	80
Refr. charge - tech. limit	150g / 5,3oz		
Free gas volume comp.	1465cm ³ / 49,5fl.oz		
Weight	8,2kg / 18,1lbs		
Motor protection	1# internal		
Winding resistance main	2,72Ω (at 25°C)		
Winding resistance aux	6,35Ω (at 25°C)		
Max. winding temp.	125°C / 257°F		
Max. discharge temp.	130°C / 266°F		



General - Configurations with DLE4.8CN

	Conf. 1
Motorconfiguration	CSIR
Power supply (nominal)	115V/60Hz
Number of phases	1
Voltage range	95-135V
Approvals	UL
Starting torque	HST
Note	Electrical equipment is included and pre-assembled to compressor.

Applications with DLE4.8CN

	Conf. 1
Refrigerant	R290
Application	LBP+MBP
System cooling	static
Hot gas defrost	OK
Long interval pull down	OK

Electrical data - Configurations with DLE4.8CN

	Conf. 1
Starting device type	relay
Run capacitor	-/-
Start capacitor	240μF
LRA (locked rotor amps / 4s)	21,14A
RLA (rated load amps / 1s)	3,64A
Cut in current	21,14A
IP class	21

Model

Designation	DLE4.8CN	115-127V/60Hz 1~	Sales code:	102H3583
-------------	-----------------	------------------	-------------	-----------------

Compressor dimensions

Housing	A Height	174mm / 6,85in
	B Height	168mm / 6,61in
	C Length shell	183mm / 7,2in
	D Length w. cover	232mm / 9,13in
	E Width	156mm / 6,14in

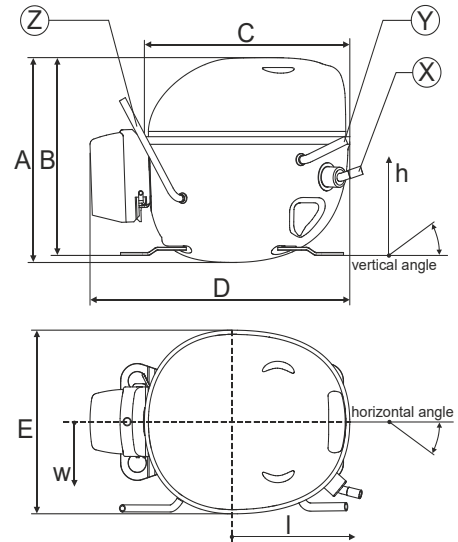

Connectors		Suction	Discharge	Process
		X	Y	Z
Diameter	[mm]	øi 8,11-8,29	øi 6,41-6,59	øi 6,4-6,6
	(i:inside, o:outside) [in]	øi 0,32-0,33	øi 0,25-0,26	øi 0,25-0,26
Material		copper	copper	copper
Horizontal angle	±2°	10°	0°	0°
Vertical angle	±2°	18°	25°	119°
Position l/h/w	[mm]	135/77/67	98/96/72	-98/133/73
	[in]	5,3/3/2,6	3,8/3,8/2,8	-3,9/5,2/2,9
Straight tube l.	[mm]	12	12	12
	[in]	0,5	0,5	0,5

Compressor fixation

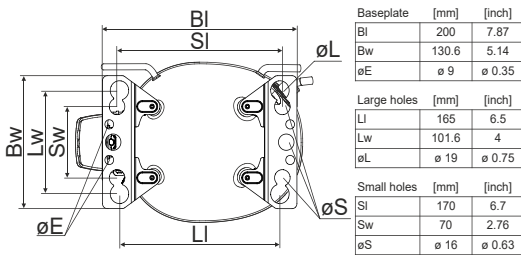

Bolt joint

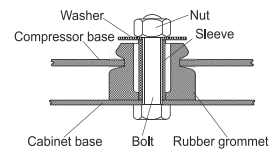

Snap-on

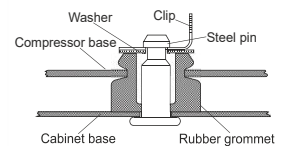

Mounting accessories	one comp.	multi pack
Bolt joint M6 ø16mm	118-1917	118-1918
Bolt joint ø1/4" ø16mm	118-1946	
Bolt joint ø1/4" ø19mm	118-1949	
Snap-on ø7,3 ø16mm	118-1947	118-1919

Model

Designation	DLE4.8CN	115V/60Hz	Conf. 1	Sales code:	102H3583
-------------	-----------------	------------------	----------------	-------------	-----------------

Configuration

Motorconfiguration	CSIR	
Power supply (nominal)	115V/60Hz 1~	
Refrigerant	R290	
Application	LBP+MBP	
Voltage range	95-135V	
Starting torque	HST	
Approvals	UL	SA3693

Electrical accessories / wiring diagram

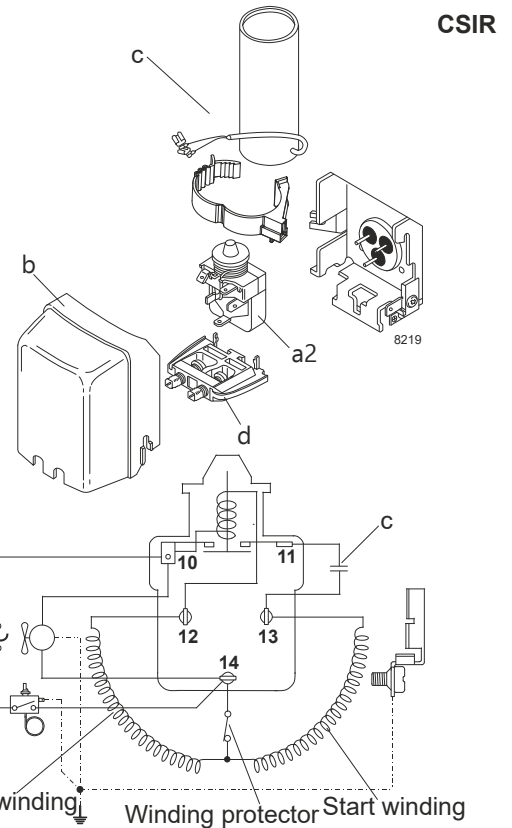

Ambient temperatures / system cooling

Ambient temperature min.:	10°C / 50°F
Ambient temperature max.:	43°C / 110°F

System cooling (n/a: outside limits)			
T ambient	LBP	MBP	HBP
32°C / 90°F	static	static	n/a
38°C / 100°F	static	static	n/a
43°C / 110°F	fan 3m/s	fan 3m/s	n/a

Operation pressure range

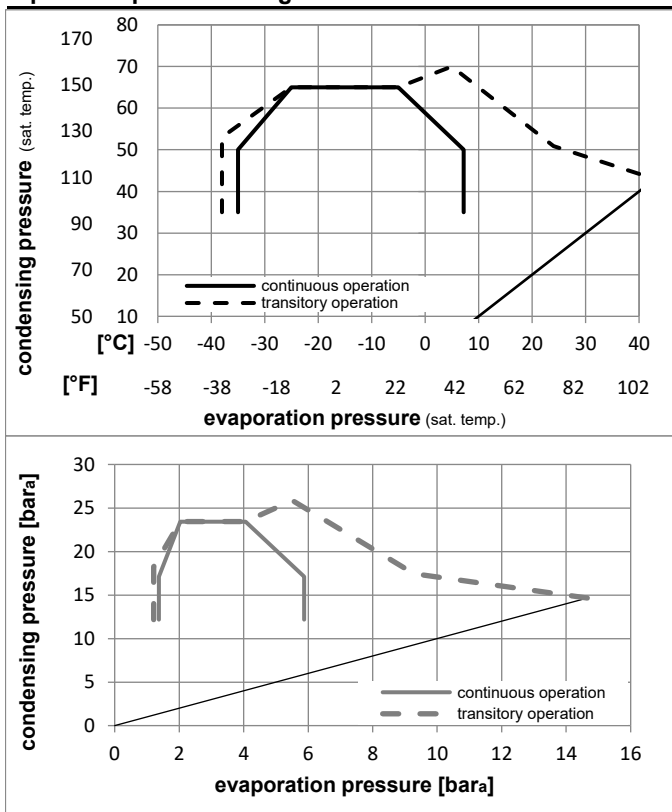

Components (already pre-assembled)

a2	relay	117U7011
c	start capacitor (240µF)	117U5023
b	plastic cover	103N0492
d	cord relief	103N1010

Model

Designation **DLE4.8CN 115V/60Hz** Conf. 1 Sales code: **102H3583**

Optimization + standard conditions

115V/60Hz 1~, CSIR, fan 3m/s, UL

Evaporating pressure (saturation temperature)														
Condensing pressure (saturation temperature)														
Return gas temp.														
Liquid temp.														
Cooling capacity														
COP														
EER														
Power consumption														
Current consumption														
Ref. mass flow														
	pe	pc	RGT	Tliq	[W]	[Btu/h]	[kcal/h]	[W/W]	[Btu/Wh]	[kcal/Wh]	P1	I	m	
[°C]	[°C]	[°C]	[°C]	[W]	[Btu/h]	[kcal/h]	[W/W]	[Btu/Wh]	[kcal/Wh]	[W]	[A]	[kg/h]		
[°C]	-23,3	54,4	32,2	32,2	284,6	972	245,0	1,47	5,00	1,26	194,3	2,63	2,88	ASHRAE LBP
[°F]	-10	130	90	90										
[°C]	-25	55	32	55	213,2	728	183,5	1,13	3,87	0,97	188,2	2,60	2,65	cecomaf LBP
[°F]	-13	131	89,6	131										
[°C]	-35	40	20	40	168,5	576	145,0	1,13	3,86	0,97	148,9	2,37	1,93	EN12900 LBP
[°F]	-31	104	68	104										
[°C]	-6,66	54,4	35	46,1	504,3	1722	434,0	2,00	6,82	1,72	252,4	3,00	5,75	ASHRAE MBP
[°F]	20	130	95	115										
[°C]	-10	55	32	55	401,3	1370	345,3	1,65	5,64	1,42	243,1	2,94	5,08	cecomaf MBP
[°F]	14	131	89,6	131										
[°C]	-10	45	20	45	448,6	1532	386,1	1,99	6,81	1,72	225,0	2,80	5,51	EN12900 MBP
[°F]	14	113	68	113										

Performance tables

115V/60Hz 1~, CSIR, fan 3m/s, UL

	pe	Cooling capacity			COP			EER			P1	I	m
	[°C]	[°F]	[W]	[Btu/h]	[kcal/h]	[W/W]	[Btu/Wh]	[kcal/Wh]	[W]	[A]	[kg/h]		
[°C / °F]	-35	-31	160,0	546	137,7	1,06	3,62	0,91	150,9	2,38	1,79		
cond. pressure	-23,3	-10	272,4	930	234,4	1,47	5,00	1,26	185,9	2,58	3,08		
pc= 45/113	-15	5	384,4	1313	330,9	1,82	6,23	1,57	210,9	2,72	4,37		
return gas temp.	-9,4	15	477,0	1629	410,5	2,11	7,19	1,81	226,5	2,81	5,46		
RGT= 32/90	-3,9	25	585,8	2001	504,1	2,43	8,31	2,09	240,9	2,89	6,75		
liquid temp	0	32	672,5	2297	578,7	2,69	9,19	2,32	249,8	2,94	7,80		
Tliq= 45/113	7,2	45	858,6	2932	738,9	3,26	11,13	2,80	263,6	3,02	10,09		
[°C / °F]	-35	-31	124,2	424	106,9	0,84	2,86	0,72	148,0	2,41	1,54		
cond. pressure	-23,3	-10	230,4	787	198,3	1,18	4,04	1,02	194,7	2,64	2,87		
pc= 55/131	-15	5	329,7	1126	283,7	1,46	4,98	1,26	226,0	2,82	4,15		
return gas temp	-9,4	15	409,9	1400	352,7	1,67	5,72	1,44	244,9	2,95	5,19		
RGT= 32/90	-3,9	25	503,1	1718	433,0	1,92	6,57	1,65	261,7	3,08	6,42		
liquid temp	0	32	577,1	1971	496,7	2,12	7,25	1,83	271,9	3,16	7,41		
Tliq= 55/131	7,2	45	735,6	2512	633,1	2,56	8,75	2,21	287,1	3,32	9,58		