

Model

Designation	DLE4.8CN	115-127V/60Hz 1~	Sales code:	102H3587
-------------	-----------------	-------------------------	-------------	-----------------

Compressor design

Oil type	Polyolester	Refrigerant(s)	R290
Oil viscosity	32cSt	Displacement	4,8cm ³ / 0,29cu.in
Oil quantity	221cm ³ / 7,5fl.oz	Compressors on pallet	100
Refr. charge - tech. limit	150g / 5,3oz		
Free gas volume comp.	1465cm ³ / 49,5fl.oz		
Weight	8kg / 17,6lbs		
Motor protection	1# internal		
Winding resistance main	2,72Ω (at 25°C)		
Winding resistance aux	6,35Ω (at 25°C)		
Max. winding temp.	125°C / 257°F		
Max. discharge temp.	130°C / 266°F		



General - Configurations with DLE4.8CN

	Conf. 1	Conf. 2	Conf. 3
Motorconfiguration	CSIR	RSIR	RSCR
Power supply (nominal)	115V/60Hz	115V/60Hz	115V/60Hz
Number of phases	1	1	1
Voltage range	95-135V	95-135V	95-135V
Approvals	UL, CCC	UL, CCC	UL, CCC
Starting torque	HST	LST	LST
Note	Housing with dip-tray fixture (omega bracket).		

Applications with DLE4.8CN

	Conf. 1	Conf. 2	Conf. 3
Refrigerant	R290	R290	R290
Application	LBP+MBP	LBP+MBP	LBP+MBP
System cooling	static	static	static
Hot gas defrost	OK	OK	OK
Long interval pull down	OK	OK	OK

Electrical data - Configurations with DLE4.8CN

	Conf. 1	Conf. 2	Conf. 3
Starting device type	relay	PTC	PTC
Run capacitor	-/-	-/-	15μF
Start capacitor	240μF	-/-	-/-
LRA (locked rotor amps / 4s)	21,14A	17,59A	17,59A
RLA (rated load amps / 1s)	3,64A	3,64A	3,35A
Cut in current	21,14A	25,4A	25,4A
IP class	21	21	21

Model

Designation	DLE4.8CN	115-127V/60Hz 1~	Sales code:	102H3587
-------------	-----------------	------------------	-------------	-----------------

Compressor dimensions

Housing	A Height	174mm / 6,85in
	B Height	168mm / 6,61in
	C Length shell	183mm / 7,2in
	D Length w. cover	232mm / 9,13in
	E Width	156mm / 6,14in

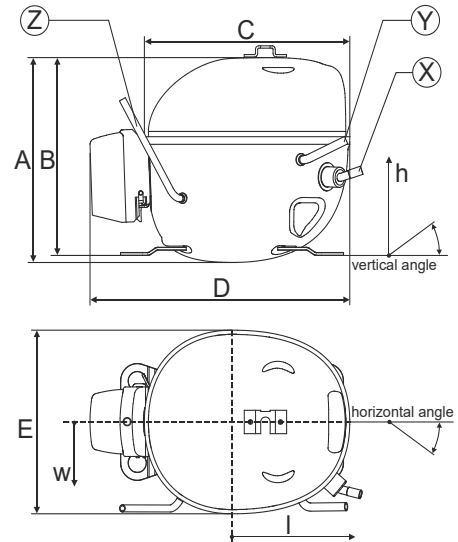

Connectors		Suction	Discharge	Process
		X	Y	Z
Diameter	[mm]	øi 8,11-8,29	øi 6,41-6,59	øi 6,4-6,6
(i:inside, o:outside)	[in]	øi 0,32-0,33	øi 0,25-0,26	øi 0,25-0,26
Material		copper	copper	copper
Horizontal angle	±2°	10°	0°	0°
Vertical angle	±2°	18°	25°	119°
Position l/h/w	[mm]	135/77/67	98/96/72	-98/133/73
	[in]	5,3/3/2,6	3,8/3,8/2,8	-3,9/5,2/2,9
Straight tube l.	[mm]	12	12	12
	[in]	0,5	0,5	0,5

Compressor fixation

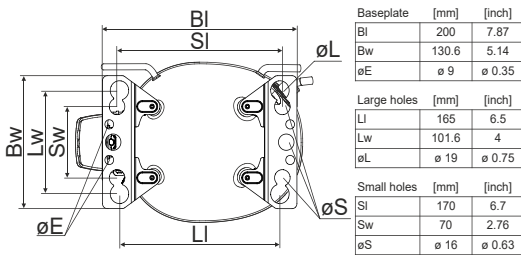

Bolt joint

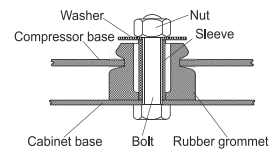

Snap-on

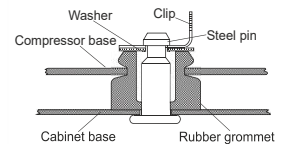

Mounting accessories

	one comp.	multi pack
Bolt joint M6 ø16mm	118-1917	118-1918
Bolt joint ø1/4" ø16mm	118-1946	
Bolt joint ø1/4" ø19mm	118-1949	
Snap-on ø7,3 ø16mm	118-1947	118-1919

Application notes

Housing with dip-tray fixture (omega bracket).

Model

Designation **DLE4.8CN 115V/60Hz** Conf. 1 Sales code: **102H3587**

Configuration

Motorconfiguration CSIR
 Power supply (nominal) 115V/60Hz 1~
 Refrigerant R290
 Application LBP+MBP
 Voltage range 95-135V
 Starting torque HST
 Approvals UL SA3693
 CCC

Electrical accessories / wiring diagram

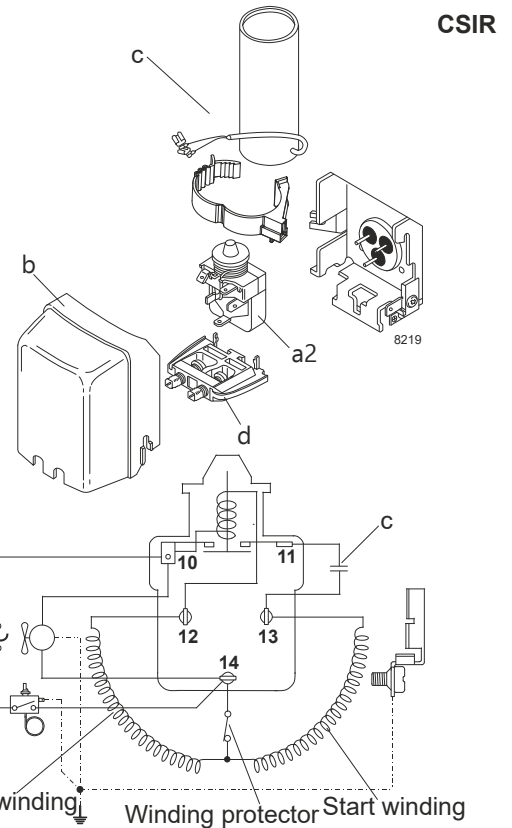

Ambient temperatures / system cooling

Ambient temperature min.: 10°C / 50°F
 Ambient temperature max.: 43°C / 110°F

System cooling (n/a: outside limits)			
T ambient	LBP	MBP	HBP
32°C / 90°F	static	static	n/a
38°C / 100°F	static	static	n/a
43°C / 110°F	fan 3m/s	fan 3m/s	n/a

Operation pressure range

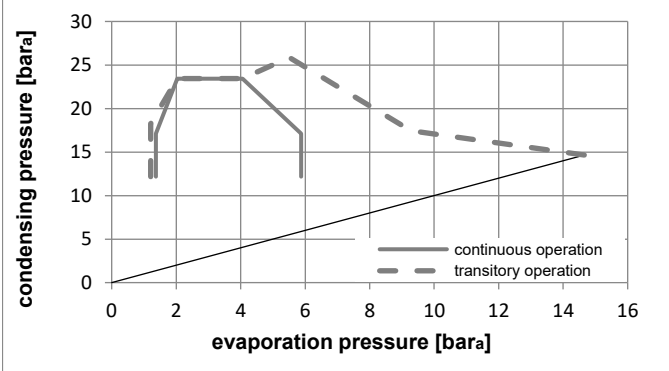
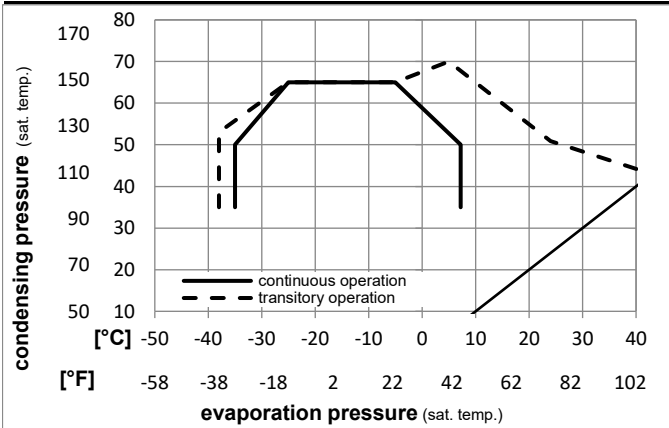

Components

- a2 relay 117U7011
- c start capacitor (240µF) 117U5023
- b plastic cover 103N0492
- d cord relief 103N1010

Model

Designation **DLE4.8CN 115V/60Hz** Conf. 1 Sales code: **102H3587**

Optimization + standard conditions

115V/60Hz 1~, CSIR, fan 3m/s, UL, CCC

	Evaporating pressure (saturation temperature)				Condensing pressure (saturation temperature)						Power consumption			ASHRAE LBP				
	pe	pc	RGT	Tliq	Cooling capacity			COP	EER	P1	I	Ref. mass flow						
	[°C]	[°F]	[°C]	[°F]	[W]	[Btu/h]	[kcal/h]	[W/W]	[Btu/Wh]	[kcal/Wh]	[W]	[A]	[kg/h]					
	-23,3	-10	54,4	130	32,2	90	32,2	90	284,6	972	245,0	1,47	5,00	1,26	194,3	2,63	2,88	ASHRAE LBP
	-25	-13	55	131	32	89,6	55	131	213,2	728	183,5	1,13	3,87	0,97	188,2	2,60	2,65	cecomaf LBP
	-35	-31	40	104	20	68	40	104	168,5	576	145,0	1,13	3,86	0,97	148,9	2,37	1,93	EN12900 LBP
	-6,66	20	54,4	130	35	95	46,1	115	504,3	1722	434,0	2,00	6,82	1,72	252,4	3,00	5,75	ASHRAE MBP
	-10	14	55	131	32	89,6	55	131	401,3	1370	345,3	1,65	5,64	1,42	243,1	2,94	5,08	cecomaf MBP
	-10	14	45	113	20	68	45	113	448,6	1532	386,1	1,99	6,81	1,72	225,0	2,80	5,51	EN12900 MBP

Performance tables

115V/60Hz 1~, CSIR, fan 3m/s, UL, CCC

	pe	Cooling capacity			COP	EER	P1	I	m		
	[°C]	[°F]	[W]	[Btu/h]	[kcal/h]	[W/W]	[Btu/Wh]	[kcal/Wh]	[W]	[A]	[kg/h]
[°C / °F]	-35	-31	160,0	546	137,7	1,06	3,62	0,91	150,9	2,38	1,79
cond. pressure	-23,3	-10	272,4	930	234,4	1,47	5,00	1,26	185,9	2,58	3,08
pc= 45/113	-15	5	384,4	1313	330,9	1,82	6,23	1,57	210,9	2,72	4,37
return gas temp.	-9,4	15	477,0	1629	410,5	2,11	7,19	1,81	226,5	2,81	5,46
RGT= 32/90	-3,9	25	585,8	2001	504,1	2,43	8,31	2,09	240,9	2,89	6,75
liquid temp	0	32	672,5	2297	578,7	2,69	9,19	2,32	249,8	2,94	7,80
Tliq= 45/113	7,2	45	858,6	2932	738,9	3,26	11,13	2,80	263,6	3,02	10,09
[°C / °F]	-35	-31	124,2	424	106,9	0,84	2,86	0,72	148,0	2,41	1,54
cond. pressure	-23,3	-10	230,4	787	198,3	1,18	4,04	1,02	194,7	2,64	2,87
pc= 55/131	-15	5	329,7	1126	283,7	1,46	4,98	1,26	226,0	2,82	4,15
return gas temp	-9,4	15	409,9	1400	352,7	1,67	5,72	1,44	244,9	2,95	5,19
RGT= 32/90	-3,9	25	503,1	1718	433,0	1,92	6,57	1,65	261,7	3,08	6,42
liquid temp	0	32	577,1	1971	496,7	2,12	7,25	1,83	271,9	3,16	7,41
Tliq= 55/131	7,2	45	735,6	2512	633,1	2,56	8,75	2,21	287,1	3,32	9,58

Model

Designation	DLE4.8CN	115V/60Hz	Conf. 2	Sales code:	102H3587
-------------	-----------------	------------------	----------------	-------------	-----------------

Configuration

Motorconfiguration	RSIR
Power supply (nominal)	115V/60Hz 1~
Refrigerant	R290
Application	LBP+MBP
Voltage range	95-135V
Starting torque	LST
Approvals	UL SA3693
	CCC

Electrical accessories / wiring diagram

RSIR

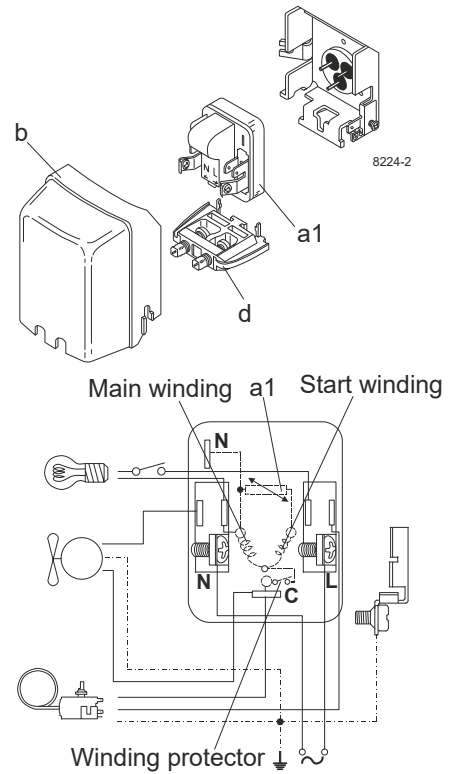

Ambient temperatures / system cooling

Ambient temperature min.:	10°C / 50°F
Ambient temperature max.:	43°C / 110°F

System cooling (n/a: outside limits)			
T ambient	LBP	MBP	HBP
32°C / 90°F	static	static	n/a
38°C / 100°F	static	static	n/a
43°C / 110°F	fan 3m/s	fan 3m/s	n/a

Operation pressure range

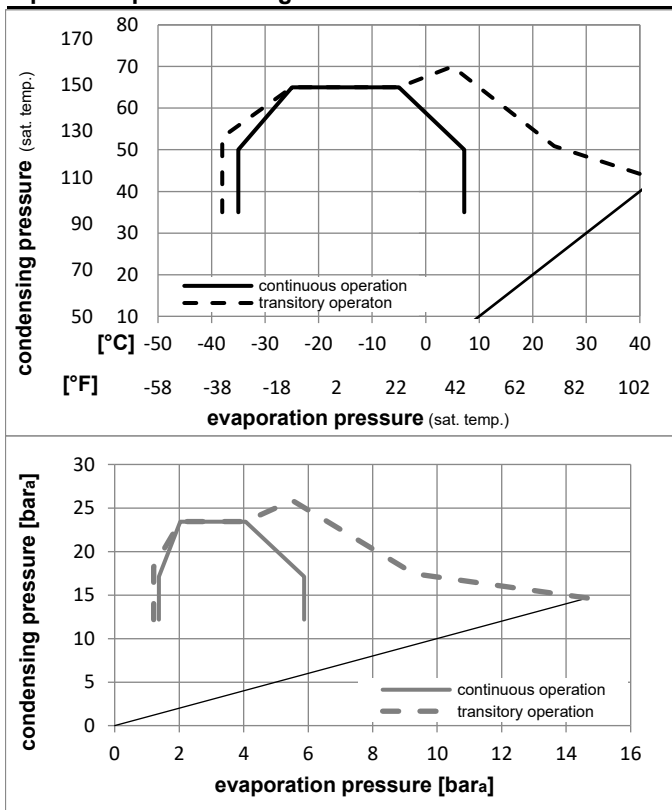

Components

a1	e-PTC starter	103N0058
b	plastic cover	103N0492
d	cord relief	103N1010

Alternative components

a1	e-PTC starter (115V, 50Ohm, 6.3mm, 4.8-cap)	103N0057
b	plastic cover	103N0492
d	cord relief	103N1010

Model

Designation **DLE4.8CN 115V/60Hz** Conf. **2** Sales code: **102H3587**

Optimization + standard conditions

115V/60Hz 1~, RSIR, fan 3m/s, UL, CCC

		Evaporating pressure (saturation temperature)				Condensing pressure (saturation temperature)						Power consumption			
		Return gas temp.		Liquid temp.		Cooling capacity			COP	EER	P1		Current consumption		Ref. mass flow
		pe	pc	RGT	Tliq	[W]	[Btu/h]	[kcal/h]	[W/W]	[Btu/Wh]	[kcal/Wh]	[W]	[A]	[kg/h]	
[°C]	-23,3	54,4	32,2	32,2	284,6	972	245,0	1,47	5,00	1,26	194,3	2,63	2,88	ASHRAE LBP	
[°F]	-10	130	90	90											
[°C]	-25	55	32	55	213,2	728	183,5	1,13	3,87	0,97	188,2	2,60	2,65	cecomaf LBP	
[°F]	-13	131	89,6	131											
[°C]	-35	40	20	40	168,5	576	145,0	1,13	3,86	0,97	148,9	2,37	1,93	EN12900 LBP	
[°F]	-31	104	68	104											
[°C]	-6,66	54,4	35	46,1	504,3	1722	434,0	2,00	6,82	1,72	252,4	3,00	5,75	ASHRAE MBP	
[°F]	20	130	95	115											
[°C]	-10	55	32	55	401,3	1370	345,3	1,65	5,64	1,42	243,1	2,94	5,08	cecomaf MBP	
[°F]	14	131	89,6	131											
[°C]	-10	45	20	45	448,6	1532	386,1	1,99	6,81	1,72	225,0	2,80	5,51	EN12900 MBP	
[°F]	14	113	68	113											

Performance tables

115V/60Hz 1~, RSIR, fan 3m/s, UL, CCC

	pe	Cooling capacity			COP	EER	P1	I	m		
	[°C]	[°F]	[W]	[Btu/h]	[kcal/h]	[W/W]	[Btu/Wh]	[kcal/Wh]	[W]	[A]	[kg/h]
[°C / °F]	-35	-31	160,0	546	137,7	1,06	3,62	0,91	150,9	2,38	1,79
cond. pressure	-23,3	-10	272,4	930	234,4	1,47	5,00	1,26	185,9	2,58	3,08
pc= 45/113	-15	5	384,4	1313	330,9	1,82	6,23	1,57	210,9	2,72	4,37
return gas temp.	-9,4	15	477,0	1629	410,5	2,11	7,19	1,81	226,5	2,81	5,46
RGT= 32/90	-3,9	25	585,8	2001	504,1	2,43	8,31	2,09	240,9	2,89	6,75
liquid temp	0	32	672,5	2297	578,7	2,69	9,19	2,32	249,8	2,94	7,80
Tliq= 45/113	7,2	45	858,6	2932	738,9	3,26	11,13	2,80	263,6	3,02	10,09
[°C / °F]	-35	-31	124,2	424	106,9	0,84	2,86	0,72	148,0	2,41	1,54
cond. pressure	-23,3	-10	230,4	787	198,3	1,18	4,04	1,02	194,7	2,64	2,87
pc= 55/131	-15	5	329,7	1126	283,7	1,46	4,98	1,26	226,0	2,82	4,15
return gas temp	-9,4	15	409,9	1400	352,7	1,67	5,72	1,44	244,9	2,95	5,19
RGT= 32/90	-3,9	25	503,1	1718	433,0	1,92	6,57	1,65	261,7	3,08	6,42
liquid temp	0	32	577,1	1971	496,7	2,12	7,25	1,83	271,9	3,16	7,41
Tliq= 55/131	7,2	45	735,6	2512	633,1	2,56	8,75	2,21	287,1	3,32	9,58

Model

Designation	DLE4.8CN	115V/60Hz	Conf. 3	Sales code:	102H3587
-------------	-----------------	------------------	----------------	-------------	-----------------

Configuration

Motorconfiguration	RSCR	
Power supply (nominal)	115V/60Hz 1~	
Refrigerant	R290	
Application	LBP+MBP	
Voltage range	95-135V	
Starting torque	LST	
Approvals	UL	SA3693
	CCC	

Electrical accessories / wiring diagram

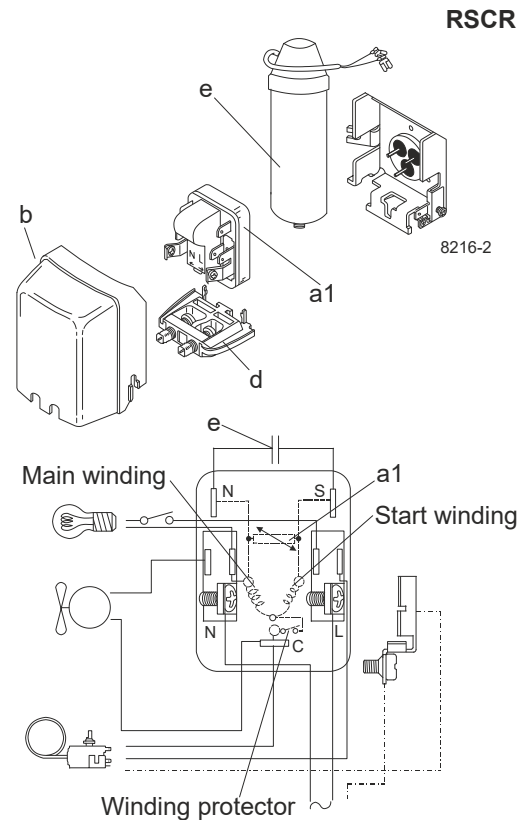

Ambient temperatures / system cooling

Ambient temperature min.:	10°C / 50°F
Ambient temperature max.:	43°C / 110°F

System cooling (n/a: outside limits)			
T ambient	LBP	MBP	HBP
32°C / 90°F	static	static	n/a
38°C / 100°F	static	static	n/a
43°C / 110°F	fan 3m/s	fan 3m/s	n/a

Operation pressure range

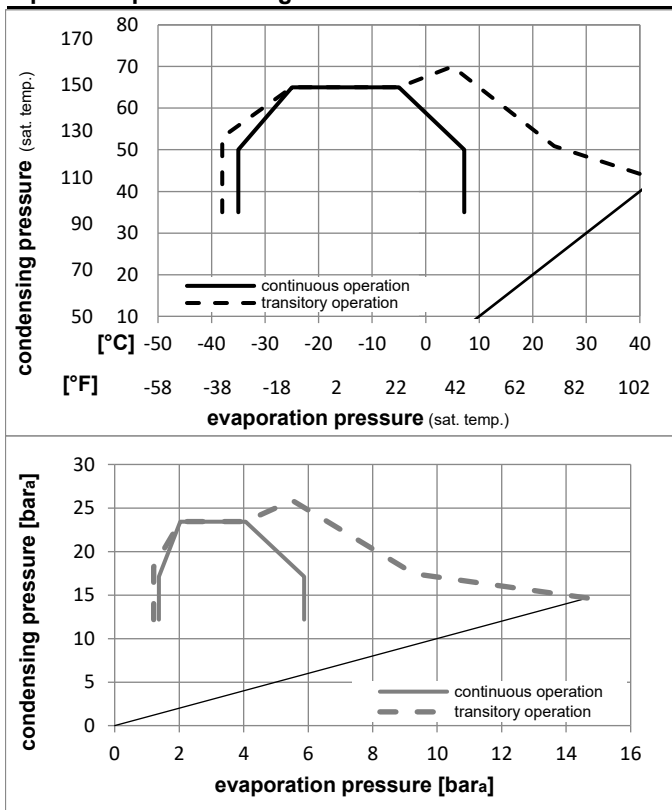

Components

a1	e-PTC starter	103N0058
e	run capacitor (15µF, 6.3mm)	117-7118
b	plastic cover	103N0492
d	cord relief	103N1010
	bracket for run capacitor	117-0300
	screw M4x8mm	117-0301

Alternative components

a1	e-PTC starter (115V, 50Ohm, 6.3mm, 4.8-cap)	103N0057
e	run capacitor (15µF, 4.8mm)	117-7120
b	plastic cover	103N0492
d	cord relief	103N1010
	bracket for run capacitor	117-0300
	screw M4x8mm	117-0301

Model

Designation **DLE4.8CN 115V/60Hz** Conf. **3** Sales code: **102H3587**

Optimization + standard conditions

115V/60Hz 1~, RSCR, fan 3m/s, UL, CCC

Evaporating pressure (saturation temperature)		Condensing pressure (saturation temperature)				Cooling capacity				COP		EER		Power consumption		ASHRAE LBP
pe		pc		RGT	Tliq		[W]	[Btu/h]	[kcal/h]	[W/W]	[Btu/Wh]	[kcal/Wh]	P1	I	Ref. mass flow	
[°C]	[°F]	[°C]	[°F]	[°C]	[°C]	[°F]	[W]	[Btu/h]	[kcal/h]	[W/W]	[Btu/Wh]	[kcal/Wh]	[W]	[A]	[kg/h]	
-23,3	54,4	32,2	32,2	290,3	992	249,9	1,56	5,34	1,34	185,8	1,89	2,94				
-10	130	90	90													
-25	55	32	55	217,4	743	187,1	1,21	4,12	1,04	180,1	1,85	2,71				
-13	131	89,6	131													
-35	40	20	40	171,9	587	147,9	1,20	4,09	1,03	143,5	1,56	1,96				
-31	104	68	104													
-6,66	54,4	35	46,1	514,4	1757	442,7	2,14	7,32	1,85	239,9	2,31	5,87				
20	130	95	115													
-10	55	32	55	409,3	1398	352,3	1,77	6,05	1,52	231,2	2,24	5,18				
14	131	89,6	131													
-10	45	20	45	457,6	1563	393,8	2,13	7,29	1,84	214,4	2,09	5,62				
14	113	68	113													

Performance tables

115V/60Hz 1~, RSCR, fan 3m/s, UL, CCC

pe	Cooling capacity			COP			EER			P1	I	m
	[°C]	[°F]	[W]	[Btu/h]	[kcal/h]	[W/W]	[Btu/Wh]	[kcal/Wh]				
[°C / °F]	-35	-31	163,2	557	140,4	1,12	3,83	0,97	145,4	1,58	1,83	
cond. pressure	-23,3	-10	277,8	949	239,1	1,56	5,33	1,34	178,0	1,82	3,14	
pc= 45/113	-15	5	392,1	1339	337,5	1,95	6,66	1,68	201,2	1,99	4,46	
return gas temp.	-9,4	15	486,5	1662	418,7	2,25	7,70	1,94	215,8	2,10	5,57	
RGT= 32/90	-3,9	25	597,5	2041	514,2	2,61	8,91	2,24	229,1	2,20	6,89	
liquid temp	0	32	685,9	2342	590,3	2,89	9,86	2,49	237,5	2,26	7,96	
Tliq= 45/113	7,2	45	875,7	2991	753,7	3,50	11,95	3,01	250,4	2,35	10,29	
[°C / °F]	-35	-31	126,6	433	109,0	0,89	3,03	0,76	142,7	1,60	1,57	
cond. pressure	-23,3	-10	235,0	803	202,3	1,26	4,31	1,09	186,2	1,89	2,93	
pc= 55/131	-15	5	336,3	1148	289,4	1,56	5,33	1,34	215,3	2,11	4,23	
return gas temp	-9,4	15	418,1	1428	359,8	1,80	6,13	1,54	232,9	2,25	5,29	
RGT= 32/90	-3,9	25	513,2	1753	441,7	2,06	7,05	1,78	248,5	2,39	6,55	
liquid temp	0	32	588,7	2010	506,6	2,28	7,79	1,96	258,1	2,48	7,56	
Tliq= 55/131	7,2	45	750,3	2563	645,7	2,76	9,41	2,37	272,3	2,63	9,78	