

**Model**

Designation	<b>DLE4.8CN</b>	<b>220-240V/50Hz 1~</b>	Sales code:	<b>102H4585</b>
-------------	-----------------	-------------------------	-------------	-----------------

**Compressor design**

Oil type	Polyolester	Refrigerant(s)	<b>R290</b>
Oil viscosity	32cSt	Displacement	4,8cm <sup>3</sup> / 0,29cu.in
Oil quantity	221cm <sup>3</sup> / 7,5fl.oz	Compressors on pallet	80
Refr. charge - tech. limit	150g / 5,3oz		
Free gas volume comp.	1390cm <sup>3</sup> / 47fl.oz		
Weight	8,15kg / 18lbs		
Motor protection	1# internal		
Winding resistance main	17,3Ω (at 25°C)		
Winding resistance aux	18,76Ω (at 25°C)		
Max. winding temp.	125°C / 257°F		
Max. discharge temp.	130°C / 266°F		



**General - Configurations with DLE4.8CN**

	<b>Conf. 1</b>
Motorconfiguration	CSIR
Power supply (nominal)	220-240V/50Hz
Number of phases	1
Voltage range	198-254V
Approvals	VDE, CCC
Starting torque	HST
Note	Electrical equipment is included and pre-assembled to compressor.

**Applications with DLE4.8CN**

	<b>Conf. 1</b>
Refrigerant	R290
Application	LBP+MBP
System cooling	fan 3m/s
Hot gas defrost	OK
Long interval pull down	OK

**Electrical data - Configurations with DLE4.8CN**

	<b>Conf. 1</b>
Starting device type	relay
Run capacitor	-/-
Start capacitor	60μF
LRA (locked rotor amps / 4s)	6,54A
RLA (rated load amps / 1s)	1,25A
Cut in current	6,54A
IP class	21

**Model**

Designation	<b>DLE4.8CN</b>	<b>220-240V/50Hz 1~</b>	Sales code:	<b>102H4585</b>
-------------	-----------------	-------------------------	-------------	-----------------

**Compressor dimensions**

<b>Housing</b>	A Height	174mm / 6,85in
	B Height	168mm / 6,61in
	C Length shell	183mm / 7,2in
	D Length w. cover	232mm / 9,13in
	E Width	156mm / 6,14in

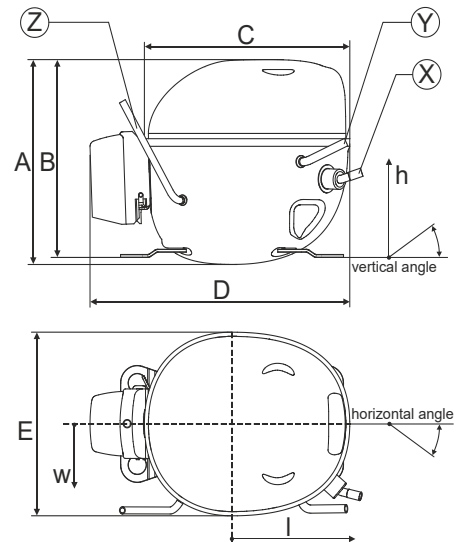

<b>Connectors</b>		<b>Suction</b>	<b>Discharge</b>	<b>Process</b>
		<b>X</b>	<b>Y</b>	<b>Z</b>
Diameter	[mm]	øi 8,11-8,29	øi 6,11-6,29	øi 6,1-6,3
(i:inside, o:outside)	[in]	øi 0,32-0,33	øi 0,24-0,25	øi 0,24-0,25
Material		copper	copper	copper
Horizontal angle	±2°	10°	0°	0°
Vertical angle	±2°	18°	25°	119°
Position l/h/w	[mm]	135/77/67	98/96/72	-98/133/73
	[in]	5,3/3/2,6	3,8/3,8/2,8	-3,9/5,2/2,9
Straight tube l.	[mm]	12	12	12
	[in]	0,5	0,5	0,5

**Compressor fixation**

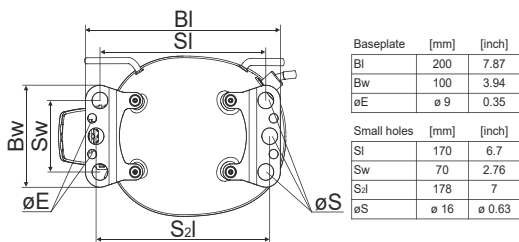

**Bolt joint**

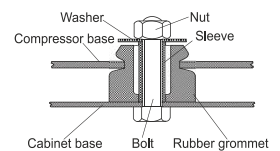

**Snap-on**

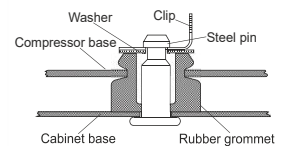

<b>Mounting accessories</b>	one comp.	multi pack
Bolt joint   M6   ø16mm	118-1917	118-1918
Bolt joint   ø1/4"   ø16mm	118-1946	
Snap-on   ø7,3   ø16mm	118-1947	118-1919

**Model**

Designation	<b>DLE4.8CN</b>	<b>220-240V/50Hz</b>	<b>Conf. 1</b>	Sales code:	<b>102H4585</b>
-------------	-----------------	----------------------	----------------	-------------	-----------------

**Configuration**

Motorconfiguration	CSIR
Power supply (nominal)	220-240V/50Hz 1~
Refrigerant	R290
Application	LBP+MBP
Voltage range	198-254V
Starting torque	HST
Approvals	VDE
	CCC

**Electrical accessories / wiring diagram**

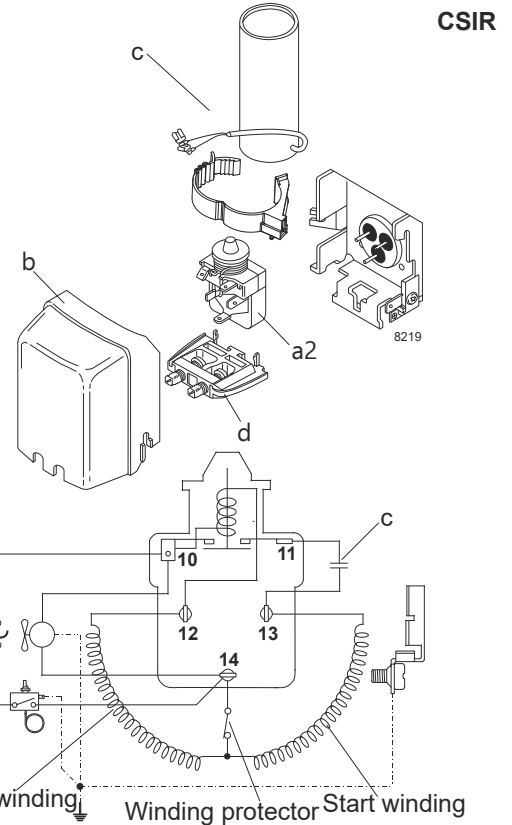

**Ambient temperatures / system cooling**

Ambient temperature min.:	10°C / 50°F
Ambient temperature max.:	43°C / 110°F

System cooling (n/a: outside limits)			
T ambient	LBP	MBP	HBP
32°C / 90°F	fan 3m/s	fan 3m/s	n/a
38°C / 100°F	fan 3m/s	fan 3m/s	n/a
43°C / 110°F	fan 3m/s	fan 3m/s	n/a

**Operation pressure range**

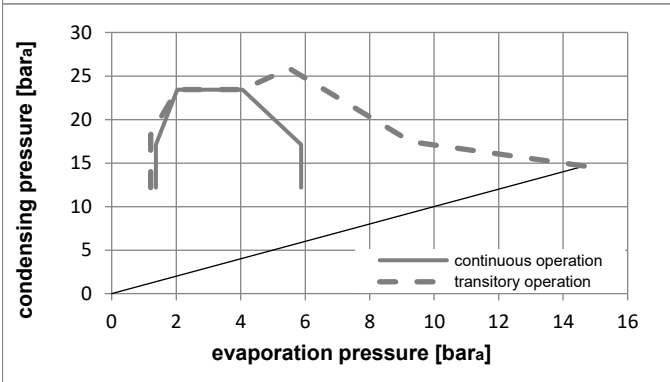
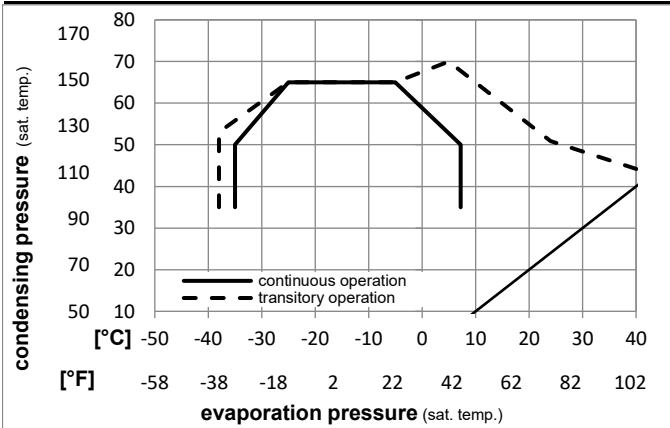

**Components (already pre-assembled)**

a2	current relay	117U7001
c	start capacitor (60μF)	117U5014
b	plastic cover	103N0491
d	cord relief	103N1010

**Model**

Designation **DLE4.8CN 220-240V/50Hz** Conf. 1 Sales code: **102H4585**

**Optimization + standard conditions**

220-240V/50Hz 1~, CSIR, fan 3m/s, VDE, CCC

	Evaporating pressure (saturation temperature)				Condensing pressure (saturation temperature)						Power consumption			ASHRAE LBP
	pe	pc	RGT	Tliq	Cooling capacity			COP	EER	P1	I	Ref. mass flow		
	[°C]	[°C]	[°C]	[°C]	[W]	[Btu/h]	[kcal/h]	[W/W]	[Btu/Wh]	[kcal/Wh]	[W]	[A]	[kg/h]	
	-23,3	54,4	32,2	32,2	242,1	827	208,3	1,56	5,32	1,34	155,3	1,01	2,45	ASHRAE LBP
	[-10]	130	90	90										
	-25	55	32	55	182,3	623	156,9	1,21	4,14	1,04	150,2	0,99	2,27	cecomaf LBP
	[-13]	131	89,6	131										
	-35	40	20	40	114,0	389	98,1	0,99	3,37	0,85	115,6	0,86	1,30	EN12900 LBP
	[-31]	104	68	104										
	-6,66	54,4	35	46,1	415,7	1420	357,8	1,98	6,75	1,70	210,4	1,20	4,74	ASHRAE MBP
	[20]	130	95	115										
	-10	55	32	55	330,8	1130	284,6	1,65	5,62	1,42	200,9	1,17	4,18	cecomaf MBP
	[14]	131	89,6	131										
	-10	45	20	45	362,5	1238	312,0	2,00	6,81	1,72	181,7	1,09	4,45	EN12900 MBP
	[14]	113	68	113										

**Performance tables**

220-240V/50Hz 1~, CSIR, fan 3m/s, VDE, CCC

	pe	Cooling capacity			COP	EER	P1	I	m		
	[°C]	[°F]	[W]	[Btu/h]	[kcal/h]	[W/W]	[Btu/Wh]	[kcal/Wh]	[W]	[A]	[kg/h]
[°C / °F]	-35	-31	107,0	365	92,1	0,91	3,10	0,78	117,9	0,87	1,20
cond. pressure	-25	-13	200,9	686	172,9	1,40	4,80	1,21	143,0	0,96	2,27
pc= 45/113	-15	5	310,5	1061	267,3	1,83	6,26	1,58	169,4	1,05	3,53
return gas temp.	-10	14	377,4	1289	324,8	2,08	7,09	1,79	181,7	1,09	4,32
RGT= 32/90	-5	23	455,5	1556	392,0	2,36	8,07	2,03	192,8	1,13	5,24
liquid temp	0	32	547,4	1869	471,1	2,71	9,25	2,33	202,2	1,17	6,35
Tliq= 45/113	7,2	45	708,6	2420	609,8	3,35	11,44	2,88	211,6	1,21	8,33
[°C / °F]	-35	-31	103,9	355	89,5	0,87	2,99	0,75	118,9	0,89	1,29
cond. pressure	-25	-13	182,3	623	156,9	1,21	4,14	1,04	150,2	0,99	2,27
pc= 55/131	-15	5	273,9	935	235,7	1,49	5,08	1,28	184,2	1,11	3,44
return gas temp	-10	14	330,8	1130	284,6	1,65	5,62	1,42	200,9	1,17	4,18
RGT= 32/90	-5	23	398,2	1360	342,7	1,84	6,27	1,58	216,9	1,23	5,07
liquid temp	0	32	478,8	1635	412,1	2,07	7,07	1,78	231,4	1,29	6,15
Tliq= 55/131	7,2	45	622,7	2127	535,9	2,50	8,54	2,15	249,0	1,37	8,11