

Model

Designation	DLE5.7CN	115-127V/60Hz 1~	Sales code:	102H3682
-------------	-----------------	-------------------------	-------------	-----------------

Compressor design

Oil type	Polyolester	Refrigerant(s)	R290
Oil viscosity	32cSt	Displacement	5,7cm ³ / 0,35cu.in
Oil quantity	221cm ³ / 7,5fl.oz	Compressors on pallet	100
Refr. charge - tech. limit	150g / 5,3oz		
Free gas volume comp.	1465cm ³ / 49,5fl.oz		
Weight	8,2kg / 18,1lbs		
Motor protection	1# internal		
Winding resistance main	2,72Ω (at 25°C)		
Winding resistance aux	6,35Ω (at 25°C)		
Max. winding temp.	125°C / 257°F		
Max. discharge temp.	130°C / 266°F		



General - Configurations with DLE5.7CN

	Conf. 1	Conf. 2	Conf. 3
Motorconfiguration	CSIR	RSIR	RSCR
Power supply (nominal)	115-127V/60Hz	115-127V/60Hz	115-127V/60Hz
Number of phases	1	1	1
Voltage range	95-135V	95-135V	95-135V
Approvals	UL, CCC	UL, CCC	UL, CCC
Starting torque	HST	LST	LST
Note	- / -		

Applications with DLE5.7CN

	Conf. 1	Conf. 2	Conf. 3
Refrigerant	R290	R290	R290
Application	LBP+MBP	LBP+MBP	LBP+MBP
System cooling	fan 3m/s	fan 3m/s	fan 3m/s
Hot gas defrost	OK	OK	OK
Long interval pull down	OK	OK	OK

Electrical data - Configurations with DLE5.7CN

	Conf. 1	Conf. 2	Conf. 3
Starting device type	relay	PTC	PTC
Run capacitor	-/-	-/-	15μF
Start capacitor	240μF	-/-	-/-
LRA (locked rotor amps / 4s)	21,14A	17,59A	17,59A
RLA (rated load amps / 1s)	3,64A	3,64A	3,35A
Cut in current	21,14A	25,4A	25,4A
IP class	21	21	21

Model

Designation	DLE5.7CN	115-127V/60Hz 1~	Sales code:	102H3682
-------------	-----------------	------------------	-------------	-----------------

Compressor dimensions

Housing	A Height	174mm / 6,85in
	B Height	168mm / 6,61in
	C Length shell	183mm / 7,2in
	D Length w. cover	232mm / 9,13in
	E Width	156mm / 6,14in

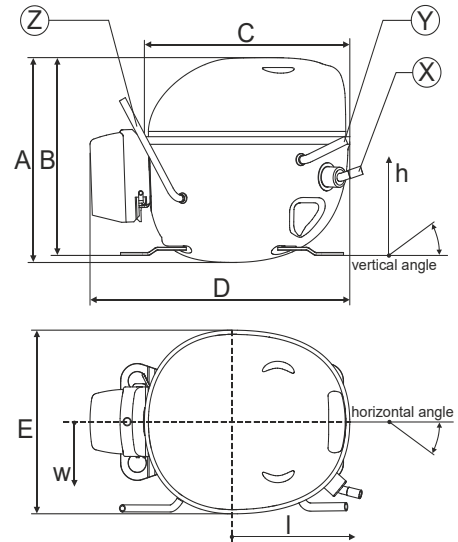

Connectors		Suction	Discharge	Process
		X	Y	Z
Diameter	[mm]	øi 8,11-8,29	øi 6,41-6,59	øi 6,4-6,6
(i:inside, o:outside)	[in]	øi 0,32-0,33	øi 0,25-0,26	øi 0,25-0,26
Material		copper	copper	copper
Horizontal angle	±2°	10°	0°	0°
Vertical angle	±2°	18°	25°	119°
Position l/h/w	[mm]	135/77/67	98/96/72	-98/133/73
	[in]	5,3/3/2,6	3,8/3,8/2,8	-3,9/5,2/2,9
Straight tube l.	[mm]	12	12	12
	[in]	0,5	0,5	0,5

Compressor fixation

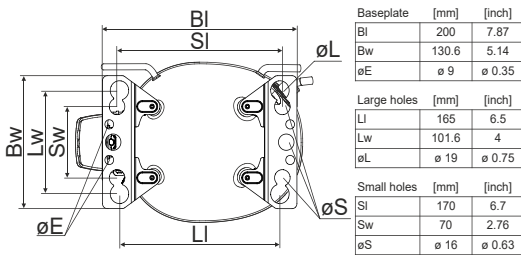

Bolt joint

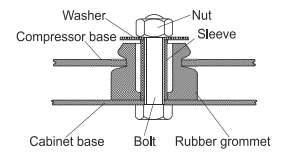

Snap-on

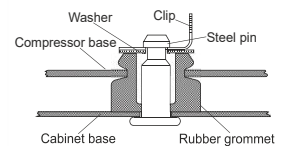

Mounting accessories	one comp.	multi pack
Bolt joint M6 ø16mm	118-1917	118-1918
Bolt joint ø1/4" ø16mm	118-1946	
Bolt joint ø1/4" ø19mm	118-1949	
Snap-on ø7,3 ø16mm	118-1947	118-1919

Model

Designation	DLE5.7CN	115-127V/60Hz	Conf. 1	Sales code:	102H3682
-------------	-----------------	----------------------	----------------	-------------	-----------------

Configuration

Motorconfiguration	CSIR	
Power supply (nominal)	115-127V/60Hz 1~	
Refrigerant	R290	
Application	LBP+MBP	
Voltage range	95-135V	
Starting torque	HST	
Approvals	UL	SA3693
	CCC	

Electrical accessories / wiring diagram

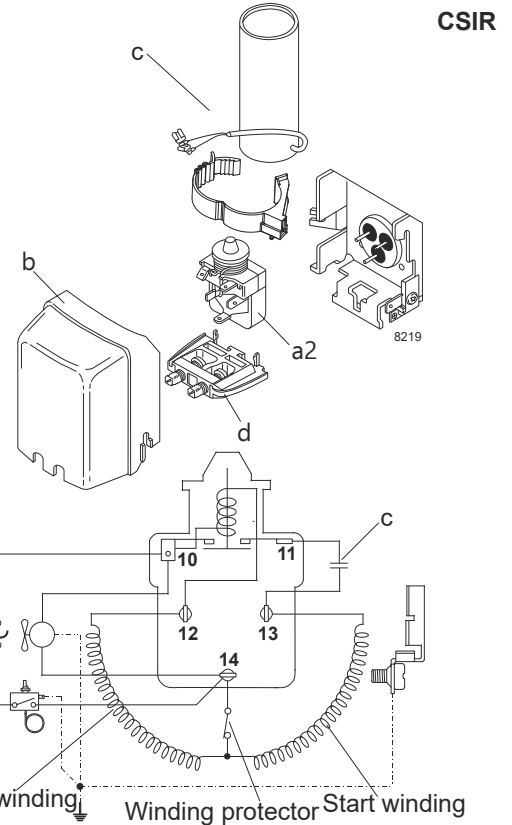

Ambient temperatures / system cooling

Ambient temperature min.:	10°C / 50°F
Ambient temperature max.:	43°C / 110°F

System cooling (n/a: outside limits)			
T ambient	LBP	MBP	HBP
32°C / 90°F	fan 3m/s	fan 3m/s	n/a
38°C / 100°F	fan 3m/s	fan 3m/s	n/a
43°C / 110°F	fan 3m/s	fan 3m/s	n/a

Operation pressure range

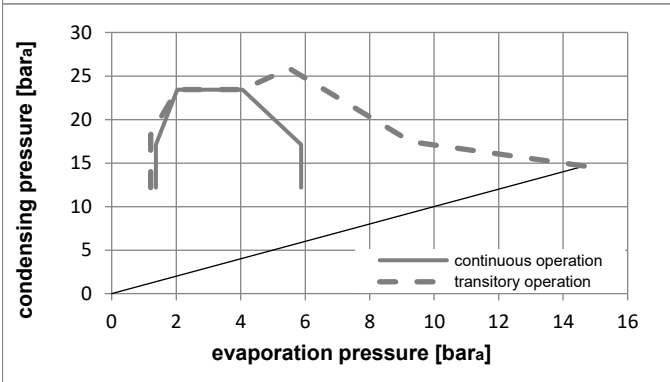
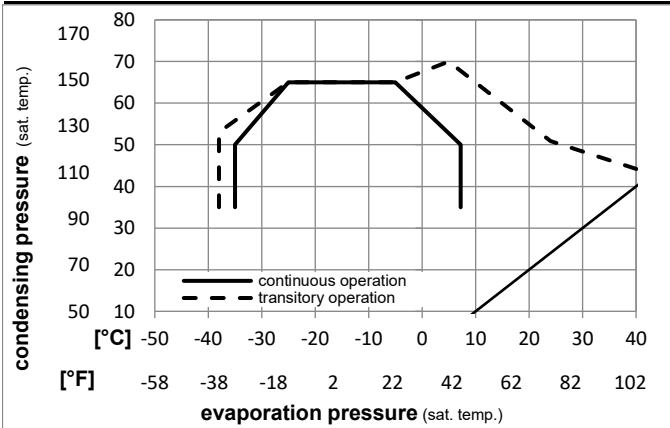

Components

a2	relay	117U7011
c	start capacitor (240µF)	117U5023
b	plastic cover	103N0492
d	cord relief	103N1010

Model

Designation **DLE5.7CN 115-127V/60Hz** Conf. 1 Sales code: **102H3682**

Optimization + standard conditions

115-127V/60Hz 1~, CSIR, fan 3m/s, UL, CCC

	Evaporating pressure (saturation temperature)				Condensing pressure (saturation temperature)						Power consumption			ASHRAE LBP
	pe	pc	RGT	Tliq	Cooling capacity			COP	EER	P1	I	Ref. mass flow		
	[°C]	[°C]	[°C]	[°C]	[W]	[Btu/h]	[kcal/h]	[W/W]	[Btu/Wh]	[kcal/Wh]	[W]	[A]	[kg/h]	
	-23,3	54,4	32,2	32,2	347,8	1188	299,4	1,49	5,10	1,29	232,9	2,90	3,52	
	[°F]													
	-10	130	90	90										
	-25	55	32	55	261,2	892	224,8	1,16	3,96	1,00	225,3	2,86	3,25	cecomaf LBP
	[°F]													
	-13	131	89,6	131										
	-35	40	20	40	199,0	680	171,2	1,16	3,96	1,00	171,6	2,57	2,27	EN12900 LBP
	[°F]													
	-31	104	68	104										
	-6,66	54,4	35	46,1	609,3	2081	524,4	1,96	6,69	1,69	311,0	3,45	6,95	ASHRAE MBP
	[°F]													
	20	130	95	115										
	-10	55	32	55	485,8	1659	418,1	1,63	5,57	1,40	297,7	3,35	6,15	cecomaf MBP
	[°F]													
	14	131	89,6	131										
	-10	45	20	45	538,7	1840	463,6	1,98	6,75	1,70	272,4	3,18	6,61	EN12900 MBP
	[°F]													
	14	113	68	113										

Performance tables

115-127V/60Hz 1~, CSIR, fan 3m/s, UL, CCC

	pe	Cooling capacity			COP	EER	P1	I	m		
	[°C]	[°F]	[W]	[Btu/h]	[kcal/h]	[W/W]	[Btu/Wh]	[kcal/Wh]	[W]	[A]	[kg/h]
[°C / °F]	-35	-31	190,5	650	163,9	1,09	3,73	0,94	174,3	2,58	2,13
cond. pressure	-23,3	-10	328,7	1122	282,9	1,49	5,09	1,28	220,5	2,83	3,71
pc= 45/113	-15	5	463,1	1582	398,5	1,83	6,24	1,57	253,5	3,04	5,27
return gas temp.	-9,4	15	572,6	1955	492,8	2,09	7,13	1,80	274,4	3,19	6,55
RGT= 32/90	-3,9	25	700,0	2391	602,4	2,38	8,13	2,05	294,0	3,34	8,07
liquid temp	0	32	800,8	2735	689,2	2,61	8,92	2,25	306,4	3,43	9,29
Tliq= 45/113	7,2	45	1015,6	3469	874,1	3,11	10,63	2,68	326,4	3,59	11,93
[°C / °F]	-35	-31	156,3	534	134,5	0,89	3,03	0,76	176,4	2,58	1,93
cond. pressure	-23,3	-10	281,7	962	242,4	1,21	4,12	1,04	233,6	2,91	3,51
pc= 55/131	-15	5	400,2	1367	344,5	1,46	4,98	1,26	274,2	3,18	5,03
return gas temp	-9,4	15	496,1	1694	426,9	1,65	5,64	1,42	300,2	3,37	6,28
RGT= 32/90	-3,9	25	607,3	2074	522,7	1,87	6,39	1,61	324,7	3,56	7,75
liquid temp	0	32	695,4	2375	598,4	2,04	6,97	1,76	340,6	3,68	8,93
Tliq= 55/131	7,2	45	883,3	3016	760,1	2,41	8,22	2,07	366,8	3,90	11,51

Model

Designation	DLE5.7CN	115-127V/60Hz	Conf. 2	Sales code:	102H3682
-------------	-----------------	----------------------	----------------	-------------	-----------------

Configuration

Motorconfiguration	RSIR
Power supply (nominal)	115-127V/60Hz 1~
Refrigerant	R290
Application	LBP+MBP
Voltage range	95-135V
Starting torque	LST
Approvals	UL SA3693
	CCC

Electrical accessories / wiring diagram

RSIR

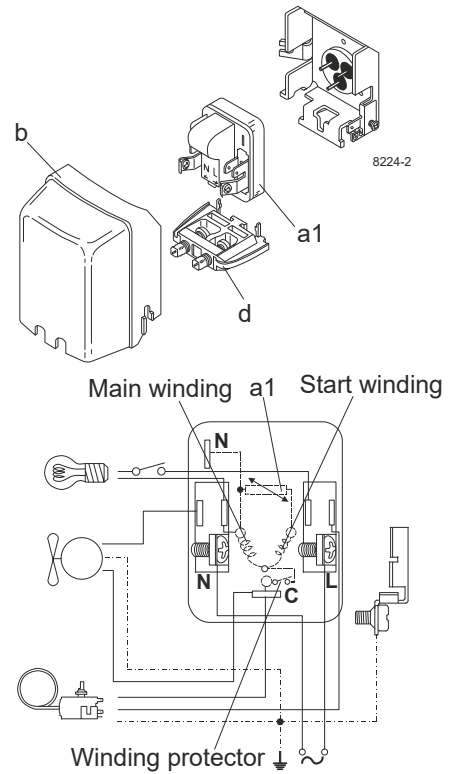

Ambient temperatures / system cooling

Ambient temperature min.:	10°C / 50°F
Ambient temperature max.:	43°C / 110°F

System cooling (n/a: outside limits)			
T ambient	LBP	MBP	HBP
32°C / 90°F	fan 3m/s	fan 3m/s	n/a
38°C / 100°F	fan 3m/s	fan 3m/s	n/a
43°C / 110°F	fan 3m/s	fan 3m/s	n/a

Operation pressure range

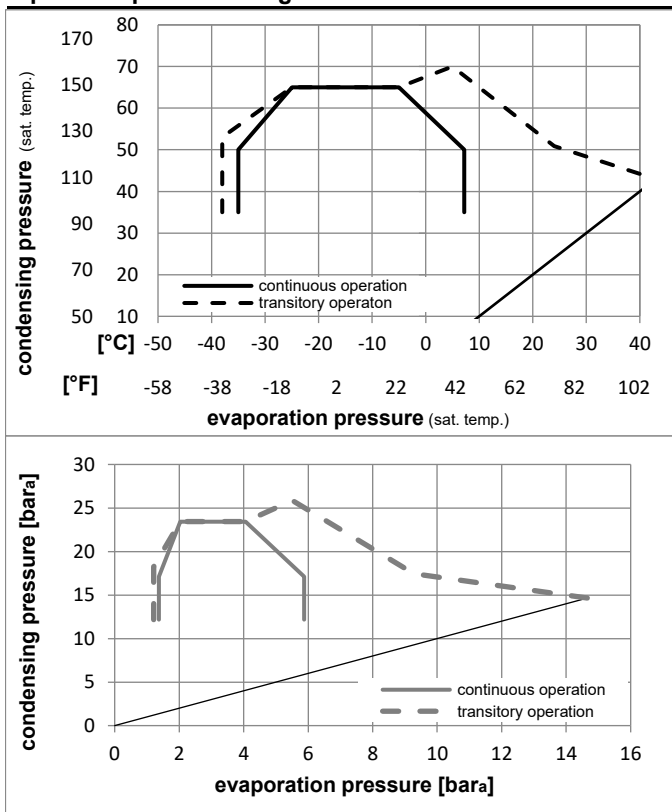

Components

a1	e-PTC starter	103N0058
b	plastic cover	103N0492
d	cord relief	103N1010

Alternative components

a1	e-PTC starter (115V, 50Ohm, 6.3mm, 4.8-cap)	103N0057
b	plastic cover	103N0492
d	cord relief	103N1010

Model

Designation **DLE5.7CN 115-127V/60Hz** Conf. **2** Sales code: **102H3682**

Optimization + standard conditions

115-127V/60Hz 1~, RSIR, fan 3m/s, UL, CCC

		Evaporating pressure (saturation temperature)				Condensing pressure (saturation temperature)						Power consumption			
		Return gas temp.				Liquid temp.						Current consumption		Ref. mass flow	
		Cooling capacity				COP		EER		P1	I	m			
		pe	pc	RGT	Tliq	[W]	[Btu/h]	[kcal/h]	[W/W]	[Btu/Wh]	[kcal/Wh]	[W]	[A]	[kg/h]	
[°C]	-23,3	54,4	32,2	32,2	347,8	1188	299,4	1,49	5,10	1,29	232,9	2,90	3,52	ASHRAE LBP	
[°F]	-10	130	90	90											
[°C]	-25	55	32	55	261,2	892	224,8	1,16	3,96	1,00	225,3	2,86	3,25	cecomaf LBP	
[°F]	-13	131	89,6	131											
[°C]	-35	40	20	40	199,0	680	171,2	1,16	3,96	1,00	171,6	2,57	2,27	EN12900 LBP	
[°F]	-31	104	68	104											
[°C]	-6,66	54,4	35	46,1	609,3	2081	524,4	1,96	6,69	1,69	311,0	3,45	6,95	ASHRAE MBP	
[°F]	20	130	95	115											
[°C]	-10	55	32	55	485,8	1659	418,1	1,63	5,57	1,40	297,7	3,35	6,15	cecomaf MBP	
[°F]	14	131	89,6	131											
[°C]	-10	45	20	45	538,7	1840	463,6	1,98	6,75	1,70	272,4	3,18	6,61	EN12900 MBP	
[°F]	14	113	68	113											

Performance tables

115-127V/60Hz 1~, RSIR, fan 3m/s, UL, CCC

	pe	Cooling capacity			COP		EER		P1	I	m
	[°C]	[°F]	[W]	[Btu/h]	[kcal/h]	[W/W]	[Btu/Wh]	[kcal/Wh]	[W]	[A]	[kg/h]
[°C / °F]	-35	-31	190,5	650	163,9	1,09	3,73	0,94	174,3	2,58	2,13
cond. pressure	-23,3	-10	328,7	1122	282,9	1,49	5,09	1,28	220,5	2,83	3,71
pc= 45/113	-15	5	463,1	1582	398,5	1,83	6,24	1,57	253,5	3,04	5,27
return gas temp.	-9,4	15	572,6	1955	492,8	2,09	7,13	1,80	274,4	3,19	6,55
RGT= 32/90	-3,9	25	700,0	2391	602,4	2,38	8,13	2,05	294,0	3,34	8,07
liquid temp	0	32	800,8	2735	689,2	2,61	8,92	2,25	306,4	3,43	9,29
Tliq= 45/113	7,2	45	1015,6	3469	874,1	3,11	10,63	2,68	326,4	3,59	11,93
[°C / °F]	-35	-31	156,3	534	134,5	0,89	3,03	0,76	176,4	2,58	1,93
cond. pressure	-23,3	-10	281,7	962	242,4	1,21	4,12	1,04	233,6	2,91	3,51
pc= 55/131	-15	5	400,2	1367	344,5	1,46	4,98	1,26	274,2	3,18	5,03
return gas temp.	-9,4	15	496,1	1694	426,9	1,65	5,64	1,42	300,2	3,37	6,28
RGT= 32/90	-3,9	25	607,3	2074	522,7	1,87	6,39	1,61	324,7	3,56	7,75
liquid temp	0	32	695,4	2375	598,4	2,04	6,97	1,76	340,6	3,68	8,93
Tliq= 55/131	7,2	45	883,3	3016	760,1	2,41	8,22	2,07	366,8	3,90	11,51

Model

Designation	DLE5.7CN	115-127V/60Hz	Conf. 3	Sales code:	102H3682
-------------	-----------------	----------------------	----------------	-------------	-----------------

Configuration

Motorconfiguration	RSCR	
Power supply (nominal)	115-127V/60Hz 1~	
Refrigerant	R290	
Application	LBP+MBP	
Voltage range	95-135V	
Starting torque	LST	
Approvals	UL	SA3693
	CCC	

Electrical accessories / wiring diagram

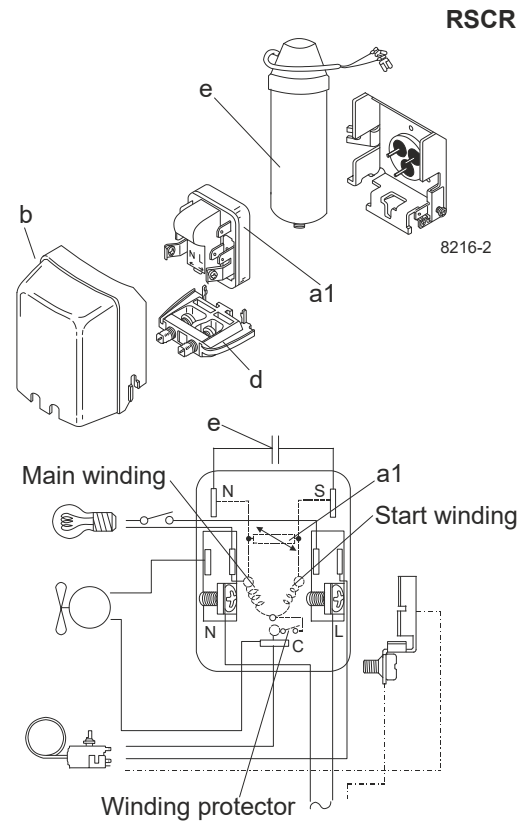

Ambient temperatures / system cooling

Ambient temperature min.:	10°C / 50°F
Ambient temperature max.:	43°C / 110°F

System cooling (n/a: outside limits)			
T ambient	LBP	MBP	HBP
32°C / 90°F	fan 3m/s	fan 3m/s	n/a
38°C / 100°F	fan 3m/s	fan 3m/s	n/a
43°C / 110°F	fan 3m/s	fan 3m/s	n/a

Operation pressure range

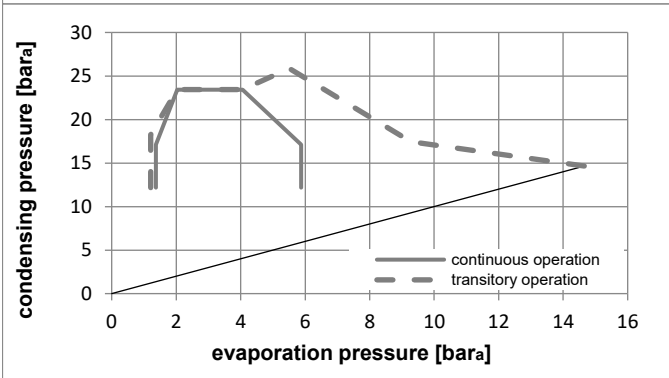
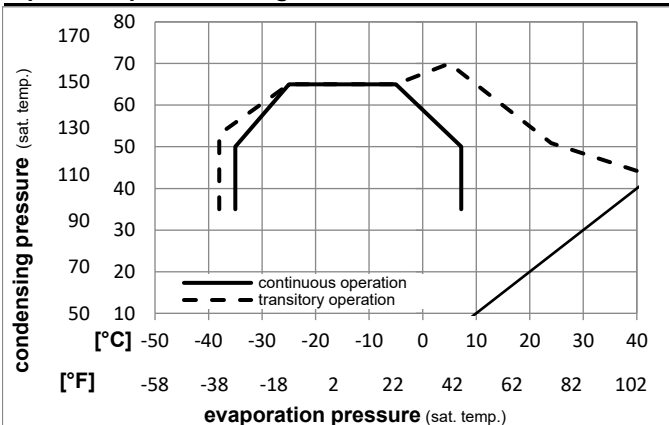

Components

a1	e-PTC starter	103N0058
e	run capacitor (15µF, 6.3mm)	117-7118
b	plastic cover	103N0492
d	cord relief	103N1010
	bracket for run capacitor	117-0300
	screw M4x8mm	117-0301

Alternative components

a1	e-PTC starter (115V, 50Ohm, 6.3mm, 4.8-cap)	103N0057
e	run capacitor (15µF, 4.8mm)	117-7120
b	plastic cover	103N0492
d	cord relief	103N1010
	bracket for run capacitor	117-0300
	screw M4x8mm	117-0301

Model

Designation **DLE5.7CN 115-127V/60Hz** Conf. **3** Sales code: **102H3682**

Optimization + standard conditions

115-127V/60Hz 1~, RSCR, fan 3m/s, UL, CCC

	Evaporating pressure (saturation temperature)				Condensing pressure (saturation temperature)						Power consumption			ASHRAE LBP
	pe	pc	RGT	Tliq	Cooling capacity			COP	EER	P1	I	Ref. mass flow		
	[°C]	[°C]	[°C]	[°C]	[W]	[Btu/h]	[kcal/h]	[W/W]	[Btu/Wh]	[kcal/Wh]	[W]	[A]	[kg/h]	
	-23,3	54,4	32,2	32,2	351,4	1200	302,4	1,60	5,46	1,38	219,6	2,74	3,56	ASHRAE LBP
	[-10]	130	90	90										
	-25	55	32	55	263,7	901	226,9	1,24	4,23	1,07	212,7	2,70	3,28	cecomaf LBP
	[-13]	131	89,6	131										
	-35	40	20	40	200,3	684	172,4	1,23	4,19	1,06	163,1	2,44	2,29	EN12900 LBP
	[-31]	104	68	104										
	-6,66	54,4	35	46,1	616,1	2104	530,2	2,11	7,22	1,82	291,4	3,24	7,03	ASHRAE MBP
	[20]	130	95	115										
	-10	55	32	55	491,5	1679	423,0	1,76	6,01	1,51	279,2	3,14	6,22	cecomaf MBP
	[14]	131	89,6	131										
	-10	45	20	45	545,0	1861	469,0	2,13	7,28	1,84	255,5	2,98	6,69	EN12900 MBP
	[14]	113	68	113										

Performance tables

115-127V/60Hz 1~, RSCR, fan 3m/s, UL, CCC

	pe	Cooling capacity			COP	EER	P1	I	m		
	[°C]	[°F]	[W]	[Btu/h]	[kcal/h]	[W/W]	[Btu/Wh]	[kcal/Wh]	[W]	[A]	[kg/h]
[°C / °F]	-35	-31	191,8	655	165,0	1,16	3,95	1,00	165,6	2,45	2,15
cond. pressure	-23,3	-10	332,1	1134	285,8	1,60	5,45	1,37	207,9	2,67	3,75
pc= 45/113	-15	5	468,6	1600	403,3	1,97	6,72	1,69	238,2	2,86	5,33
return gas temp.	-9,4	15	579,2	1978	498,5	2,25	7,68	1,94	257,4	2,99	6,63
RGT= 32/90	-3,9	25	707,3	2416	608,7	2,57	8,78	2,21	275,3	3,12	8,16
liquid temp	0	32	808,2	2760	695,5	2,82	9,63	2,43	286,7	3,21	9,37
Tliq= 45/113	7,2	45	1022,0	3490	879,5	3,35	11,44	2,88	305,0	3,36	12,01
[°C / °F]	-35	-31	157,4	538	135,5	0,94	3,21	0,81	167,7	2,46	1,95
cond. pressure	-23,3	-10	284,6	972	244,9	1,29	4,41	1,11	220,3	2,74	3,55
pc= 55/131	-15	5	405,0	1383	348,5	1,57	5,37	1,35	257,7	2,99	5,09
return gas temp	-9,4	15	501,8	1714	431,9	1,78	6,09	1,53	281,6	3,16	6,35
RGT= 32/90	-3,9	25	613,7	2096	528,2	2,02	6,89	1,74	304,1	3,33	7,83
liquid temp	0	32	701,8	2397	604,0	2,20	7,52	1,90	318,7	3,45	9,01
Tliq= 55/131	7,2	45	888,7	3035	764,8	2,59	8,85	2,23	342,8	3,65	11,58