

Model

Designation	DLE5.7CN	115-127V/60Hz 1~	Sales code:	102H3683
-------------	-----------------	-------------------------	-------------	-----------------

Compressor design

Oil type	Polyolester	Refrigerant(s)	R290
Oil viscosity	32cSt	Displacement	5,7cm ³ / 0,35cu.in
Oil quantity	221cm ³ / 7,5fl.oz	Compressors on pallet	80
Refr. charge - tech. limit	150g / 5,3oz		
Free gas volume comp.	1465cm ³ / 49,5fl.oz		
Weight	8,2kg / 18,1lbs		
Motor protection	1# internal		
Winding resistance main	2,72Ω (at 25°C)		
Winding resistance aux	6,35Ω (at 25°C)		
Max. winding temp.	125°C / 257°F		
Max. discharge temp.	130°C / 266°F		



General - Configurations with DLE5.7CN

	Conf. 1
Motorconfiguration	CSIR
Power supply (nominal)	115-127V/60Hz
Number of phases	1
Voltage range	95-135V
Approvals	UL
Starting torque	HST
Note	Electrical equipment is included and pre-assembled to compressor.

Applications with DLE5.7CN

	Conf. 1
Refrigerant	R290
Application	LBP+MBP
System cooling	fan 3m/s
Hot gas defrost	OK
Long interval pull down	OK

Electrical data - Configurations with DLE5.7CN

	Conf. 1
Starting device type	relay
Run capacitor	-/-
Start capacitor	240μF
LRA (locked rotor amps / 4s)	21,14A
RLA (rated load amps / 1s)	3,64A
Cut in current	21,14A
IP class	21

Model

Designation	DLE5.7CN	115-127V/60Hz 1~	Sales code:	102H3683
-------------	-----------------	------------------	-------------	-----------------

Compressor dimensions

Housing	A Height	174mm / 6,85in
	B Height	168mm / 6,61in
	C Length shell	183mm / 7,2in
	D Length w. cover	232mm / 9,13in
	E Width	156mm / 6,14in

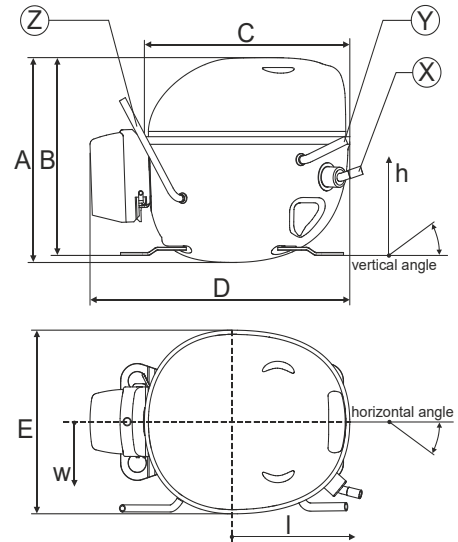

Connectors		Suction	Discharge	Process
		X	Y	Z
Diameter	[mm]	øi 8,11-8,29	øi 6,41-6,59	øi 6,4-6,6
(i:inside, o:outside)	[in]	øi 0,32-0,33	øi 0,25-0,26	øi 0,25-0,26
Material		copper	copper	copper
Horizontal angle	±2°	10°	0°	0°
Vertical angle	±2°	18°	25°	119°
Position l/h/w	[mm]	135/77/67	98/96/72	-98/133/73
	[in]	5,3/3/2,6	3,8/3,8/2,8	-3,9/5,2/2,9
Straight tube l.	[mm]	12	12	12
	[in]	0,5	0,5	0,5

Compressor fixation

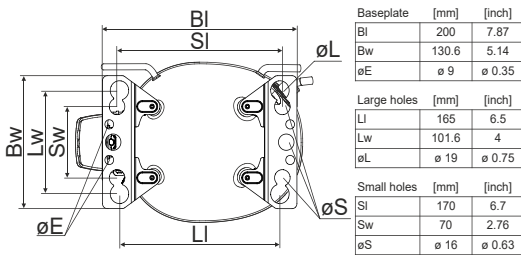

Bolt joint

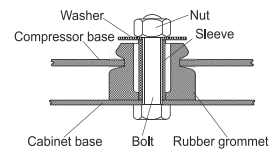

Snap-on

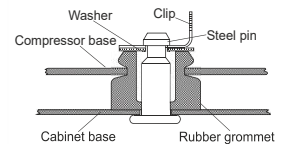

Mounting accessories	one comp.	multi pack
Bolt joint M6 ø16mm	118-1917	118-1918
Bolt joint ø1/4" ø16mm	118-1946	
Bolt joint ø1/4" ø19mm	118-1949	
Snap-on ø7,3 ø16mm	118-1947	118-1919

Model

Designation	DLE5.7CN	115-127V/60Hz	Conf. 1	Sales code:	102H3683
-------------	-----------------	----------------------	----------------	-------------	-----------------

Configuration

Motorconfiguration	CSIR
Power supply (nominal)	115-127V/60Hz 1~
Refrigerant	R290
Application	LBP+MBP
Voltage range	95-135V
Starting torque	HST
Approvals	UL SA3693

Electrical accessories / wiring diagram

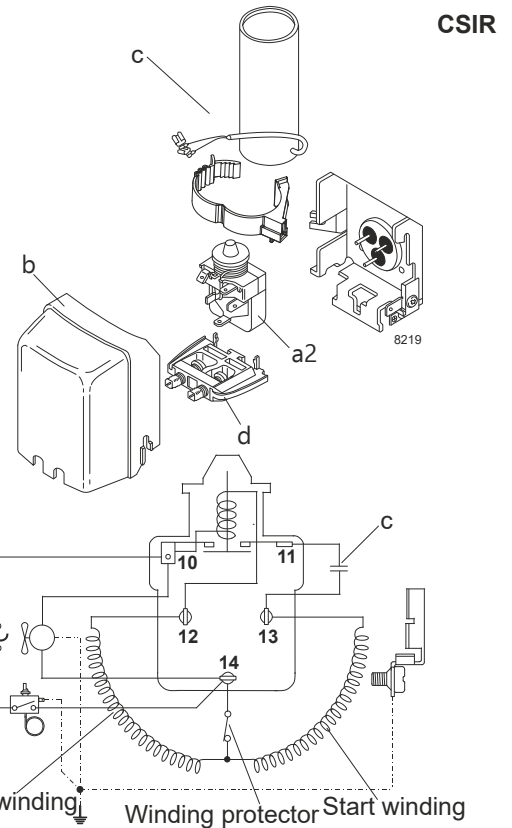

Ambient temperatures / system cooling

Ambient temperature min.:	10°C / 50°F
Ambient temperature max.:	43°C / 110°F

System cooling (n/a: outside limits)			
T ambient	LBP	MBP	HBP
32°C / 90°F	fan 3m/s	fan 3m/s	n/a
38°C / 100°F	fan 3m/s	fan 3m/s	n/a
43°C / 110°F	fan 3m/s	fan 3m/s	n/a

Operation pressure range

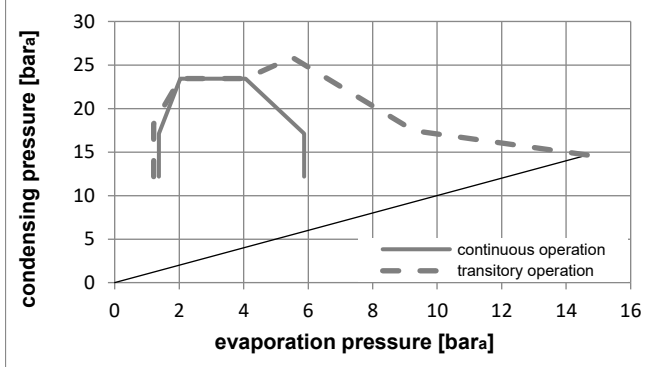
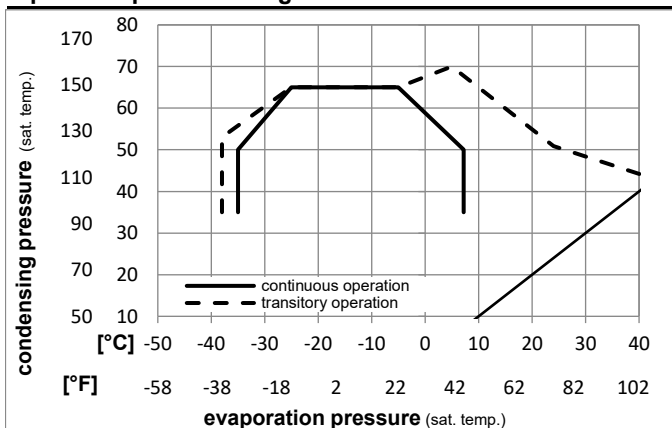

Components (already pre-assembled)

a2	relay	117U7011
c	start capacitor (240µF)	117U5023
b	plastic cover	103N0492
d	cord relief	103N1010

Model

Designation **DLE5.7CN 115-127V/60Hz** Conf. 1 Sales code: **102H3683**

Optimization + standard conditions

115-127V/60Hz 1~, CSIR, fan 3m/s, UL

	Evaporating pressure (saturation temperature)				Condensing pressure (saturation temperature)						Power consumption			ASHRAE LBP
	pe	pc	RGT	Tliq	Cooling capacity			COP	EER	P1	I	Ref. mass flow		
	[°C]	[°C]	[°C]	[°C]	[W]	[Btu/h]	[kcal/h]	[W/W]	[Btu/Wh]	[kcal/Wh]	[W]	[A]	[kg/h]	
	-23,3	54,4	32,2	32,2	347,8	1188	299,4	1,49	5,10	1,29	232,9	2,90	3,52	ASHRAE LBP
	[-10]	130	90	90										
	-25	55	32	55	261,2	892	224,8	1,16	3,96	1,00	225,3	2,86	3,25	cecomaf LBP
	[-13]	131	89,6	131										
	-35	40	20	40	199,0	680	171,2	1,16	3,96	1,00	171,6	2,57	2,27	EN12900 LBP
	[-31]	104	68	104										
	-6,66	54,4	35	46,1	609,3	2081	524,4	1,96	6,69	1,69	311,0	3,45	6,95	ASHRAE MBP
	[20]	130	95	115										
	-10	55	32	55	485,8	1659	418,1	1,63	5,57	1,40	297,7	3,35	6,15	cecomaf MBP
	[14]	131	89,6	131										
	-10	45	20	45	538,7	1840	463,6	1,98	6,75	1,70	272,4	3,18	6,61	EN12900 MBP
	[14]	113	68	113										

Performance tables

115-127V/60Hz 1~, CSIR, fan 3m/s, UL

	pe	Cooling capacity			COP			EER			P1	I	m
	[°C]	[°F]	[W]	[Btu/h]	[kcal/h]	[W/W]	[Btu/Wh]	[kcal/Wh]	[W]	[A]	[kg/h]		
[°C / °F]	-35	-31	190,5	650	163,9	1,09	3,73	0,94	174,3	2,58	2,13		
cond. pressure	-23,3	-10	328,7	1122	282,9	1,49	5,09	1,28	220,5	2,83	3,71		
pc= 45/113	-15	5	463,1	1582	398,5	1,83	6,24	1,57	253,5	3,04	5,27		
return gas temp.	-9,4	15	572,6	1955	492,8	2,09	7,13	1,80	274,4	3,19	6,55		
RGT= 32/90	-3,9	25	700,0	2391	602,4	2,38	8,13	2,05	294,0	3,34	8,07		
liquid temp	0	32	800,8	2735	689,2	2,61	8,92	2,25	306,4	3,43	9,29		
Tliq= 45/113	7,2	45	1015,6	3469	874,1	3,11	10,63	2,68	326,4	3,59	11,93		
[°C / °F]	-35	-31	156,3	534	134,5	0,89	3,03	0,76	176,4	2,58	1,93		
cond. pressure	-23,3	-10	281,7	962	242,4	1,21	4,12	1,04	233,6	2,91	3,51		
pc= 55/131	-15	5	400,2	1367	344,5	1,46	4,98	1,26	274,2	3,18	5,03		
return gas temp	-9,4	15	496,1	1694	426,9	1,65	5,64	1,42	300,2	3,37	6,28		
RGT= 32/90	-3,9	25	607,3	2074	522,7	1,87	6,39	1,61	324,7	3,56	7,75		
liquid temp	0	32	695,4	2375	598,4	2,04	6,97	1,76	340,6	3,68	8,93		
Tliq= 55/131	7,2	45	883,3	3016	760,1	2,41	8,22	2,07	366,8	3,90	11,51		