

Model

Designation	DLE5.7CN	220-240V/50Hz 1~	Sales code:	102H4665
-------------	-----------------	-------------------------	-------------	-----------------

Compressor design

Oil type	Polyolester	Refrigerant(s)	R290
Oil viscosity	32cST	Displacement	5,7cm ³ / 0,35cu.in
Oil quantity	221cm ³ / 7,5fl.oz	Compressors on pallet	80
Refr. charge - tech. limit	150g / 5,3oz		
Free gas volume comp.	1390cm ³ / 47fl.oz		
Weight	8,2kg / 18,1lbs		
Motor protection	1# internal		
Winding resistance main	13,53Ω (at 25°C)		
Winding resistance aux	14,27Ω (at 25°C)		
Max. winding temp.	125°C / 257°F		
Max. discharge temp.	130°C / 266°F		



General - Configurations with DLE5.7CN

	Conf. 1
Motorconfiguration	CSIR
Power supply (nominal)	220-240V/50Hz
Number of phases	1
Voltage range	198-254V
Approvals	VDE, CCC
Starting torque	LST
Note	Electrical equipment is included and pre-assembled to compressor.

Applications with DLE5.7CN

	Conf. 1
Refrigerant	R290
Application	LBP+MBP
System cooling	fan 3m/s
Hot gas defrost	OK
Long interval pull down	OK

Electrical data - Configurations with DLE5.7CN

	Conf. 1
Starting device type	relay
Run capacitor	-/-
Start capacitor	80μF
LRA (locked rotor amps / 4s)	7,4A
RLA (rated load amps / 1s)	1,57A
Cut in current	11,92A
IP class	21

Model

Designation

DLE5.7CN

220-240V/50Hz 1~

Sales code:

102H4665

Compressor dimensions

Housing	A Height	174mm / 6,85in
	B Height	168mm / 6,61in
	C Length shell	183mm / 7,2in
	D Length w. cover	232mm / 9,13in
	E Width	156mm / 6,14in

Connectors		Suction	Discharge	Process
		X	Y	Z
Diameter	[mm]	øi 8,11-8,29	øi 6,11-6,29	øi 6,1-6,3
(i:inside, o:outside)	[in]	øi 0,32-0,33	øi 0,24-0,25	øi 0,24-0,25
Material		copper	copper	copper
Horizontal angle	±2°	10°	0°	0°
Vertical angle	±2°	18°	25°	119°
Position l/h/w	[mm]	135/77/67	98/96/72	-98/133/73
	[in]	5,3/3/2,6	3,8/3,8/2,8	-3,9/5,2/2,9
Straight tube l.	[mm]	12	12	12
	[in]	0,5	0,5	0,5

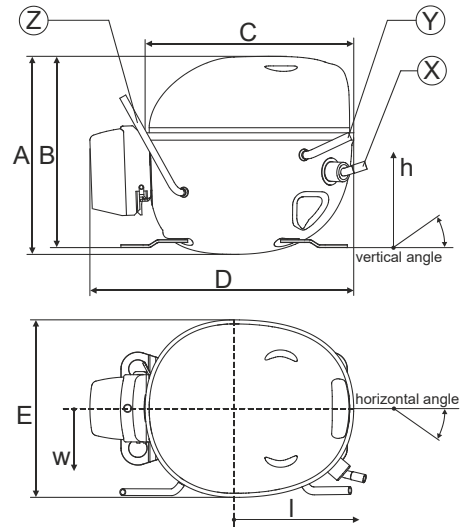

Compressor fixation

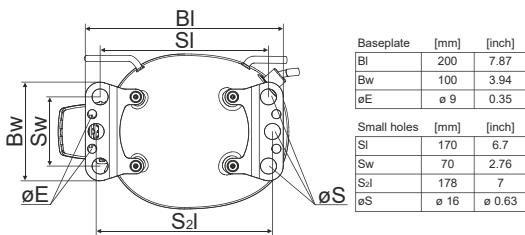

Bolt joint

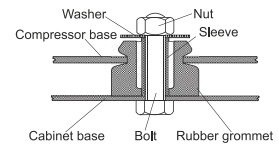

Snap-on

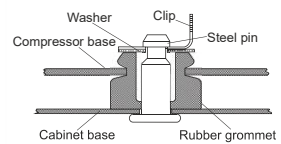

Mounting accessories

	one comp.	multi pack
Bolt joint M6 ø16mm	118-1917	118-1918
Bolt joint ø1/4" ø16mm	118-1946	
Snap-on ø7,3 ø16mm	118-1947	118-1919

Model

Designation **DLE5.7CN 220-240V/50Hz** Conf. 1 Sales code: **102H4665**

Configuration

Motorconfiguration CSIR
 Power supply (nominal) 220-240V/50Hz 1~
 Refrigerant R290
 Application LBP+MBP
 Voltage range 198-254V
 Starting torque LST
 Approvals VDE
 CCC

Electrical accessories / wiring diagram

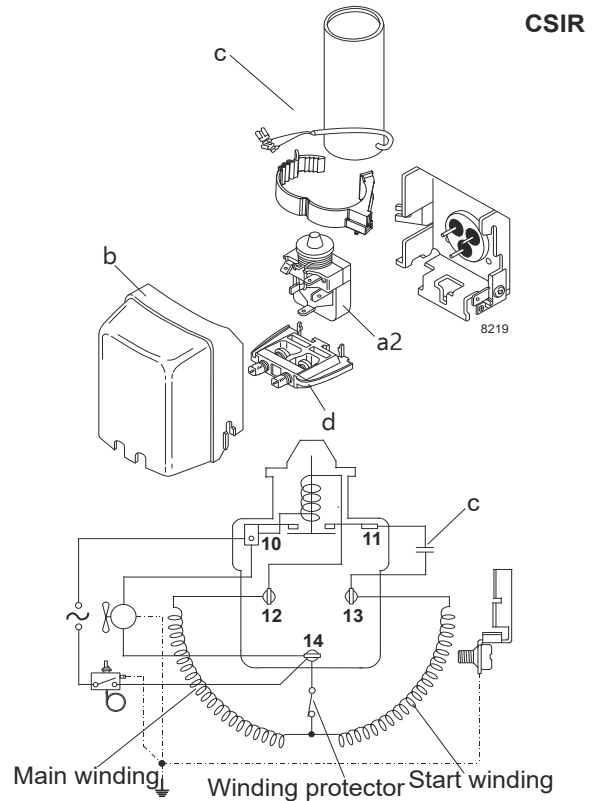

Ambient temperatures / system cooling

Ambient temperature min.: 10°C / 50°F
 Ambient temperature max.: 43°C / 110°F

System cooling (n/a: outside limits)			
T ambient	LBP	MBP	HBP
32°C / 90°F	fan 3m/s	fan 3m/s	n/a
38°C / 100°F	fan 3m/s	fan 3m/s	n/a
43°C / 110°F	fan 3m/s	fan 3m/s	n/a

Operation pressure range

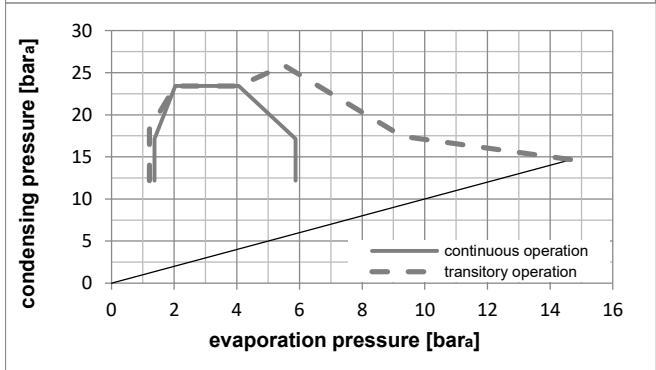
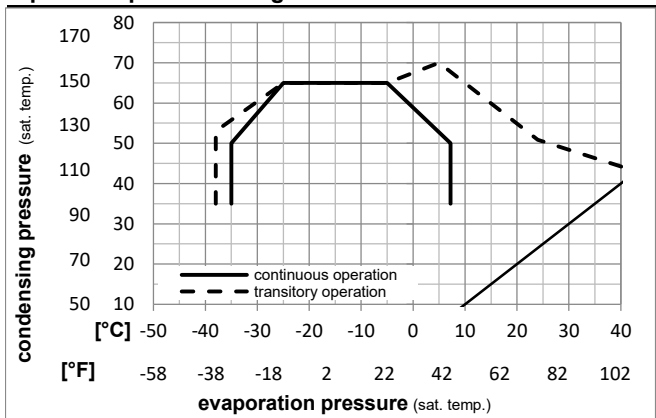

Components (already pre-assembled)

- a2 current relay 117U7015
- c start capacitor (80µF) 117U5015
- b plastic cover 103N0491
- d cord relief 103N1010

Model

Designation **DLE5.7CN 220-240V/50Hz** Conf. 1 Sales code: **102H4665**

Optimization + standard conditions

220V/50Hz, CSIR, fan 3m/s, VDE, CCC

Evaporating pressure (saturation temperature)		Condensing pressure (saturation temperature)				Cooling capacity			COP	EER	P1	Current consumption		Ref. mass flow	
pe	pc	RGT	Tliq		[W]	[Btu/h]	[kcal/h]	[W/W]	[Btu/Wh]	[kcal/Wh]	[W]	I	m		
[°C]	[°C]	[°C]	[°C]									[A]	[kg/h]		
-23,3	54,4	32,2	32,2		297,1	1015	255,7	1,52	5,21	1,31	194,9	1,28	3,01		ASHRAE LBP
[°F]															
-10	130	90	90												
-25	55	32	55		224,0	765	192,8	1,18	4,05	1,02	189,1	1,26	2,79		cecomaf LBP
[°F]															
-13	131	89,6	131												
-35	40	20	40		166,8	570	143,6	1,20	4,11	1,04	138,6	1,13	1,91		EN12900 LBP
[°F]															
-31	104	68	104												
-6,66	54,4	35	46,1		507,7	1734	437,0	1,97	6,72	1,69	258,2	1,50	5,79		ASHRAE MBP
[°C]															
[°F]															
20	130	95	115												
-10	55	32	55		405,1	1383	348,6	1,64	5,60	1,41	247,1	1,46	5,12		cecomaf MBP
[°C]															
[°F]															
14	131	89,6	131												
-10	45	20	45		446,0	1523	383,8	2,01	6,85	1,73	222,3	1,37	5,48		EN12900 MBP
[°C]															
[°F]															
14	113	68	113												

Performance tables

220V/50Hz, CSIR, fan 3m/s, VDE, CCC

	pe	Cooling capacity			COP	EER	P1	I	m		
	[°C]	[°F]	[W]	[Btu/h]	[kcal/h]	[W/W]	[Btu/Wh]	[kcal/Wh]	[W]	[A]	[kg/h]
[°C / °F]	-35	-31	162,1	554	139,5	1,14	3,90	0,98	141,9	1,13	1,82
cond. pressure	-25	-13	258,1	881	222,1	1,46	5,00	1,26	176,3	1,23	2,91
pc= 45/113	-15	5	384,5	1313	330,9	1,85	6,32	1,59	207,7	1,32	4,37
return gas temp.	-10	14	464,3	1586	399,6	2,09	7,13	1,80	222,3	1,37	5,31
RGT= 32/90	-5	23	557,9	1905	480,2	2,36	8,07	2,03	236,0	1,42	6,42
liquid temp	0	32	667,4	2279	574,4	2,68	9,16	2,31	248,8	1,47	7,74
Tliq= 45/113	7,2	45	857,2	2927	737,7	3,23	11,02	2,78	265,6	1,54	10,07
[°C / °F]	-35	-31	135,4	462	116,5	0,91	3,09	0,78	149,5	1,15	1,67
cond. pressure	-25	-13	224,0	765	192,8	1,18	4,05	1,02	189,1	1,26	2,79
pc= 55/131	-15	5	335,6	1146	288,8	1,47	5,03	1,27	228,0	1,39	4,22
return gas temp	-10	14	405,1	1383	348,6	1,64	5,60	1,41	247,1	1,46	5,12
RGT= 32/90	-5	23	486,5	1662	418,7	1,83	6,25	1,57	265,9	1,53	6,20
liquid temp	0	32	582,0	1988	500,9	2,05	6,99	1,76	284,5	1,60	7,48
Tliq= 55/131	7,2	45	748,2	2555	643,9	2,41	8,23	2,07	310,5	1,71	9,75