

Model

Designation	DLE5.7CNT	220-240V/50Hz 1~ 208-230V/60Hz 1~	Sales code:	102H4679
-------------	------------------	-----------------------------------	-------------	-----------------

Compressor design

Oil type	Polyolester	Refrigerant(s)	R290
Oil viscosity	32cST	Displacement	5,7cm ³ / 0,35cu.in
Oil quantity	223cm ³ / 7,6fl.oz	Compressors on pallet	100
Refr. charge - tech. limit	150g / 5,3oz		
Free gas volume comp.	1325cm ³ / 44,8fl.oz		
Weight	8,5kg / 18,7lbs		
Motor protection	1# internal		
Winding resistance main	10,84Ω (at 25°C)		
Winding resistance aux	11,36Ω (at 25°C)		
Max. winding temp.	125°C / 257°F		
Max. discharge temp.	130°C / 266°F		



General - Configurations with DLE5.7CNT

	Conf. 1	Conf. 2	Conf. 3	Conf. 4	Conf. 5
Motorconfiguration	CSIR	CSIR	RSIR	RSCR	RSCR
Power supply (nominal)	208-230V/60Hz	220-240V/50Hz	220-240V/50Hz	208-230V/60Hz	220-240V/50Hz
Number of phases	1	1	1	1	1
Voltage range	187-253V	187-254V	187-254V	187-253V	187-254V
Approvals	UL, CCC	UL, CCC	UL, CCC	UL, CCC	UL, CCC
Starting torque	HST	HST	LST	LST	LST
Note	Housing with dip-tray fixture (omega bracket).				

Applications with DLE5.7CNT

	Conf. 1	Conf. 2	Conf. 3	Conf. 4	Conf. 5
Refrigerant	R290	R290	R290	R290	R290
Application	LBP+MBP	LBP+MBP	LBP+MBP	LBP+MBP	LBP+MBP
System cooling	fan 3m/s	fan 3m/s	fan 3m/s	fan 3m/s	fan 3m/s
Hot gas defrost	OK	OK	OK	OK	OK
Long interval pull down	OK	OK	OK	OK	OK

Electrical data - Configurations with DLE5.7CNT

	Conf. 1	Conf. 2	Conf. 3	Conf. 4	Conf. 5
Starting device type	relay	relay	PTC	PTC	PTC
Run capacitor	-/-	-/-	-/-	5μF	5μF
Start capacitor	80μF	80μF	-/-	-/-	-/-
LRA (locked rotor amps / 4s)	9,34A	9,65A	9,18A	8,39A	9,18A
RLA (rated load amps / 1s)	1,67A	1,91A	1,91A	1,65A	1,7A
Cut in current	9,34A	9,65A	14,3A	13,34A	14,3A

Model

Designation

DLE5.7CNT

220-240V/50Hz 1~ 208-230V/60Hz 1~

Sales code:

102H4679

Compressor dimensions

Housing	A Height	174mm / 6,85in
	B Height	168mm / 6,61in
	C Length shell	183mm / 7,2in
	D Length w. cover	232mm / 9,13in
	E Width	156mm / 6,14in

Connectors		Suction	Discharge	Process
		X	Y	Z
Diameter	[mm]	øi 8,11-8,29	øi 6,41-6,59	øi 6,4-6,6
	(i:inside, o:outside) [in]	øi 0,32-0,33	øi 0,25-0,26	øi 0,25-0,26
Material		copper	copper	copper
Horizontal angle	±2°	10°	0°	0°
Vertical angle	±2°	18°	25°	119°
Position l/h/w	[mm]	135/77/67	98/96/72	-98/133/73
	[in]	5,3/3/2,6	3,8/3,8/2,8	-3,9/5,2/2,9
Straight tube l.	[mm]	12	12	12
	[in]	0,5	0,5	0,5

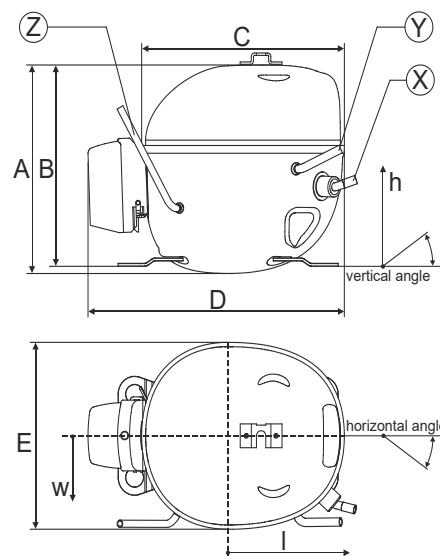

Compressor fixation

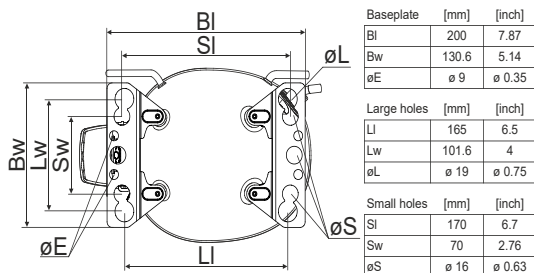

Bolt joint



Snap-on



Mounting accessories

	one comp.	multi pack
Bolt joint M6 ø16mm	118-1917	118-1918
Bolt joint ø1/4" ø16mm	118-1946	
Bolt joint ø1/4" ø19mm	118-1949	
Snap-on ø7,3 ø16mm	118-1947	118-1919

Application notes

Housing with dip-tray fixture (omega bracket).

LRA value on compressor label and datasheet may differ due to different test conditions for UL approval.

Model

Designation	DLE5.7CNT	208-230V/60Hz	Conf. 1	Sales code:	102H4679
-------------	------------------	----------------------	---------	-------------	-----------------

Configuration

Motorconfiguration	CSIR	
Power supply (nominal)	208-230V/60Hz 1~	
Refrigerant	R290	
Application	LBP+MBP	
Voltage range	187-253V	
Starting torque	HST	
Approvals	UL	SA3693
	CCC	

Electrical accessories / wiring diagram

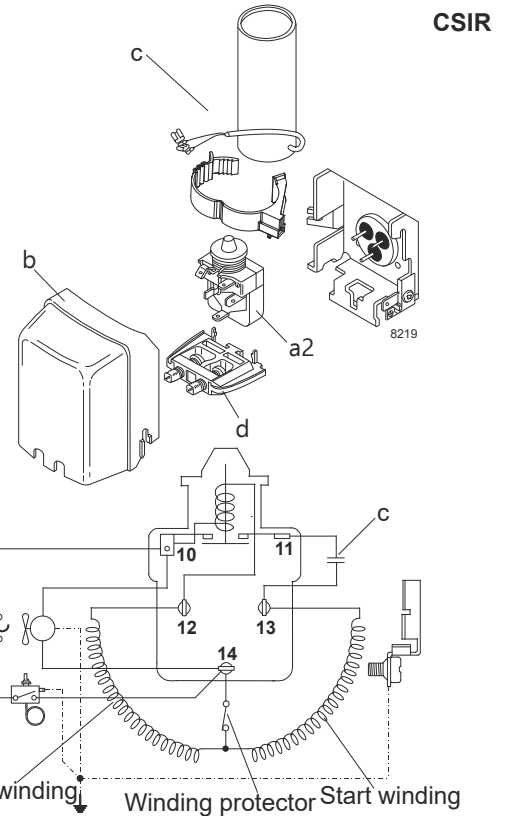

Ambient temperatures / system cooling

Ambient temperature min.:	10°C / 50°F
Ambient temperature max.:	43°C / 110°F

System cooling (n/a: outside limits)			
T ambient	LBP	MBP	HBP
32°C / 90°F	fan 3m/s	fan 3m/s	n/a
38°C / 100°F	fan 3m/s	fan 3m/s	n/a
43°C / 110°F	fan 3m/s	fan 3m/s	n/a

Operation pressure range

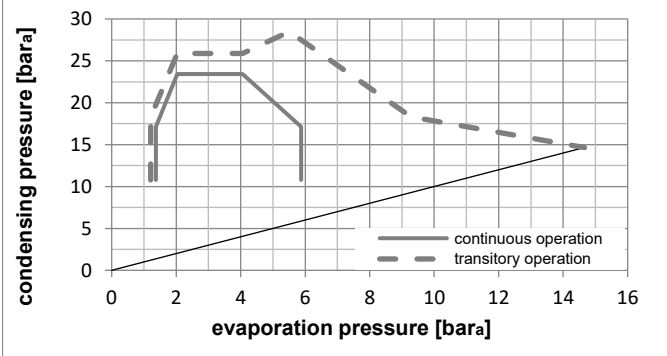
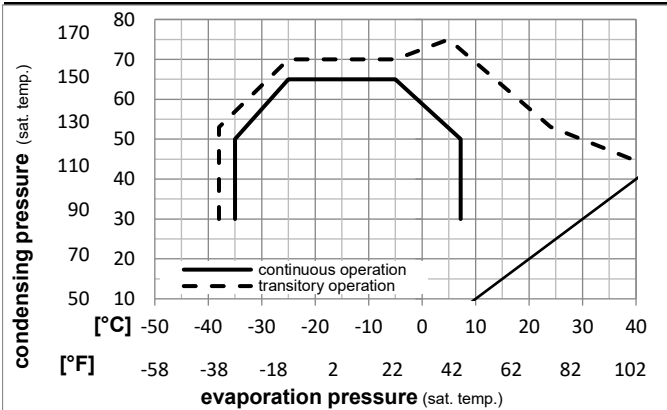

Components

a2	relay	117U7002
c	start capacitor (80µF)	117U5015
b	plastic cover	103N0491
d	cord relief	103N1010

Model

Designation **DLE5.7CNT 208-230V/60Hz** Conf. 1 Sales code: **102H4679**

Optimization + standard conditions

R290, 230V/60Hz, CSIR, fan 3m/s, UL, CCC

		Evaporating pressure (saturation temperature)				Condensing pressure (saturation temperature)			Return gas temp.			Liquid temp.			Cooling capacity			COP	EER	Power consumption			
		pe	pc	RGT	Tliq	[W]	[Btu/h]	[kcal/h]	[W/W]	[Btu/Wh]	[kcal/Wh]	P1	I	Ref. mass flow									
[°C]	[°F]	[°C]	[°F]	[°C]	[°F]							[W]	[A]	[kg/h]									
-23	54	32	32	352,7	1204	303,5	1,54	5,27	1,33	228,6	1,38	3,57	ASHRAE LBP										
-10	130	90	90																				
-25	55	32	55	265,5	907	228,5	1,20	4,09	1,03	221,4	1,36	3,31	cecomaf LBP										
-13	131	90	131																				
-35	40	20	40	198,8	679	171,1	1,20	4,11	1,04	165,2	1,19	2,27	EN12900 LBP										
-31	104	68	104																				
-7	54	35	46	611,7	2089	526,4	2,00	6,84	1,72	305,3	1,66	6,98	ASHRAE MBP										
20	130	95	115																				
-10	55	32	55	487,7	1665	419,7	1,67	5,71	1,44	291,7	1,61	6,17	cecomaf MBP										
14	131	90	131																				
-10	45	20	45	535,5	1829	460,9	2,02	6,91	1,74	264,8	1,51	6,58	EN12900 MBP										
14	113	68	113																				

Performance tables

R290, 230V/60Hz, CSIR, fan 3m/s, UL, CCC

	pe		Cooling capacity			COP	EER	P1	I	m	
	[°C]	[°F]	[W]	[Btu/h]	[kcal/h]	[W/W]	[Btu/Wh]	[kcal/Wh]	[W]	[A]	[kg/h]
[°C / °F]	-35	-31	190,8	652	164,2	1,13	3,86	0,97	168,9	1,20	2,14
cond. pressure	-23	-10	328,7	1123	282,9	1,53	5,22	1,32	215,1	1,34	3,71
pc= 45/113	-15	5	460,8	1574	396,5	1,87	6,38	1,61	246,8	1,45	5,24
return gas temp.	-9	15	569,2	1944	489,8	2,13	7,29	1,84	266,8	1,52	6,52
RGT= 32/90	-4	25	696,9	2380	599,8	2,44	8,33	2,10	285,6	1,59	8,04
liquid temp	0	32	799,2	2729	687,8	2,68	9,16	2,31	297,9	1,64	9,27
Tliq= 45/113	7,2	45	1020,6	3485	878,3	3,20	10,94	2,76	318,5	1,72	11,99
[°C / °F]	-35	-31	160,4	548	138,1	0,92	3,14	0,79	174,7	1,21	1,98
cond. pressure	-23	-10	285,7	976	245,9	1,25	4,26	1,07	229,3	1,39	3,56
pc= 55/131	-15	5	402,5	1375	346,4	1,50	5,12	1,29	268,5	1,52	5,06
return gas temp	-9	15	497,9	1701	428,5	1,69	5,78	1,46	294,3	1,62	6,30
RGT= 32/90	-4	25	610,4	2085	525,3	1,91	6,53	1,64	319,4	1,72	7,79
liquid temp	0	32	700,6	2393	603,0	2,08	7,11	1,79	336,5	1,79	9,00
Tliq= 55/131	7,2	45	896,7	3062	771,7	2,45	8,35	2,10	366,7	1,91	11,68

Model

Designation	DLE5.7CNT	220-240V/50Hz	Conf. 2	Sales code:	102H4679
-------------	------------------	----------------------	----------------	-------------	-----------------

Configuration

Motorconfiguration	CSIR	
Power supply (nominal)	220-240V/50Hz 1~	
Refrigerant	R290	
Application	LBP+MBP	
Voltage range	187-254V	
Starting torque	HST	
Approvals	UL	SA3693
	CCC	

Electrical accessories / wiring diagram

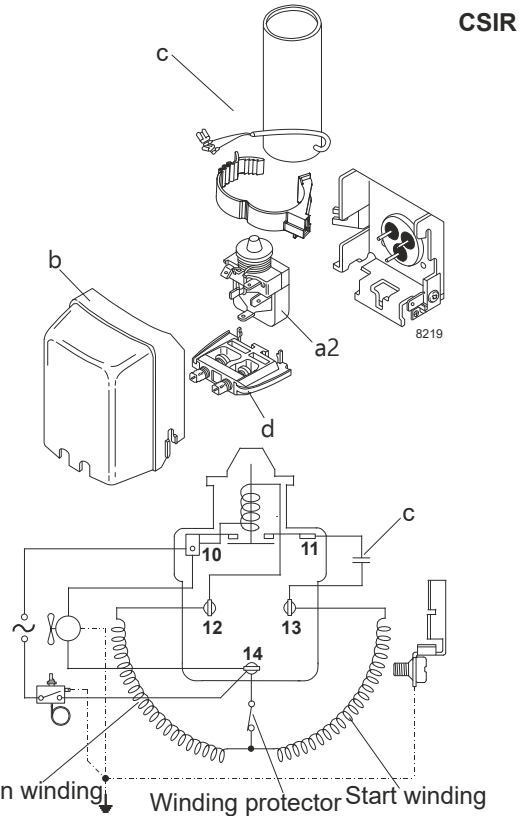

Ambient temperatures / system cooling

Ambient temperature min.:	10°C / 50°F
Ambient temperature max.:	43°C / 110°F

System cooling (n/a: outside limits)			
T ambient	LBP	MBP	HBP
32°C / 90°F	fan 3m/s	fan 3m/s	n/a
38°C / 100°F	fan 3m/s	fan 3m/s	n/a
43°C / 110°F	fan 3m/s	fan 3m/s	n/a

Operation pressure range

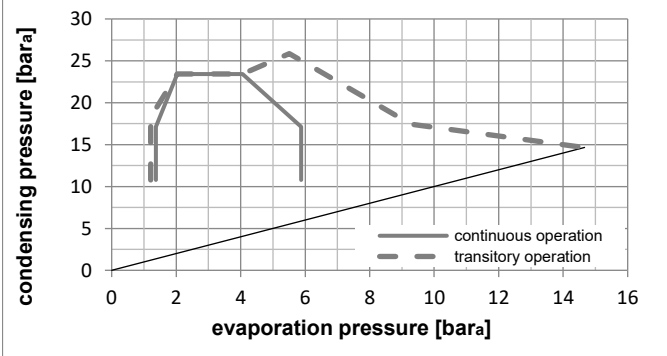
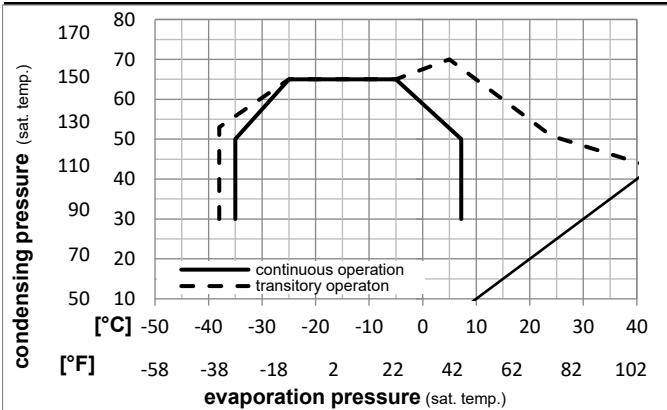

Components

a2	relay	117U7002
c	start capacitor (80µF)	117U5015
b	plastic cover	103N0491
d	cord relief	103N1010

Model

Designation **DLE5.7CNT** **220-240V/50Hz** Conf. 2 Sales code: **102H4679**

Optimization + standard conditions

R290, 220V/50Hz, CSIR, fan 3m/s, UL, CCC

		Evaporating pressure (saturation temperature)				Condensing pressure (saturation temperature)						Power consumption			
		Return gas temp.		Liquid temp.		Cooling capacity		COP	EER		P1	I	Ref. mass flow		
		pe	pc	RGT	Tliq	[W]	[Btu/h]	[kcal/h]	[W/W]	[Btu/Wh]	[kcal/Wh]	[W]	[A]	[kg/h]	
[°C]	-23	54	32	32	295,0	1007	253,9	1,45	4,96	1,25	202,9	1,47	2,99	ASHRAE LBP	
[°F]	-10	130	90	90											
[°C]	-25	55	32	55	222,2	759	191,2	1,13	3,85	0,97	197,0	1,45	2,77	cecomaf LBP	
[°F]	-13	131	90	131											
[°C]	-35	40	20	40	166,2	568	143,1	1,13	3,86	0,97	147,0	1,27	1,90	EN12900 LBP	
[°F]	-31	104	68	104											
[°C]	-7	54	35	46	510,4	1743	439,2	1,95	6,66	1,68	261,7	1,71	5,82	ASHRAE MBP	
[°F]	20	130	95	115											
[°C]	-10	55	32	55	406,8	1389	350,1	1,61	5,51	1,39	252,0	1,67	5,15	cecomaf MBP	
[°F]	14	131	90	131											
[°C]	-10	45	20	45	446,8	1526	384,5	1,95	6,67	1,68	228,8	1,57	5,49	EN12900 MBP	
[°F]	14	113	68	113											

Performance tables

R290, 220V/50Hz, CSIR, fan 3m/s, UL, CCC

	pe		Cooling capacity			COP	EER	P1	I	m	
	[°C]	[°F]	[W]	[Btu/h]	[kcal/h]	[W/W]	[Btu/Wh]				[kcal/Wh]
[°C / °F]	-35	-31	159,5	545	137,3	1,06	3,62	0,91	150,3	1,28	1,79
cond. pressure	-23	-10	274,8	939	236,5	1,44	4,92	1,24	190,9	1,43	3,10
pc= 45/113	-15	5	384,5	1313	330,9	1,78	6,09	1,53	215,6	1,52	4,37
return gas temp.	-9	15	474,8	1622	408,7	2,06	7,04	1,78	230,2	1,57	5,44
RGT= 32/90	-4	25	581,9	1987	500,8	2,39	8,17	2,06	243,3	1,63	6,71
liquid temp	0	32	668,0	2281	574,9	2,65	9,06	2,28	251,7	1,66	7,75
Tliq= 45/113	7,2	45	855,6	2922	736,3	3,22	11,01	2,77	265,4	1,72	10,05
[°C / °F]	-35	-31	134,1	458	115,4	0,86	2,94	0,74	155,6	1,29	1,66
cond. pressure	-23	-10	238,9	816	205,6	1,17	4,01	1,01	203,5	1,48	2,98
pc= 55/131	-15	5	335,9	1147	289,1	1,43	4,89	1,23	234,6	1,60	4,22
return gas temp	-9	15	415,4	1418	357,5	1,64	5,59	1,41	253,9	1,68	5,26
RGT= 32/90	-4	25	509,5	1740	438,5	1,87	6,39	1,61	272,1	1,76	6,50
liquid temp	0	32	585,5	2000	503,9	2,06	7,03	1,77	284,3	1,81	7,52
Tliq= 55/131	7,2	45	751,7	2567	646,9	2,46	8,40	2,12	305,7	1,91	9,79

Model

Designation	DLE5.7CNT	220-240V/50Hz	Conf. 3	Sales code:	102H4679
-------------	------------------	----------------------	----------------	-------------	-----------------

Configuration

Motorconfiguration	RSIR	
Power supply (nominal)	220-240V/50Hz 1~	
Refrigerant	R290	
Application	LBP+MBP	
Voltage range	187-254V	
Starting torque	LST	
Approvals	UL	SA3693
	CCC	

Electrical accessories / wiring diagram

RSIR

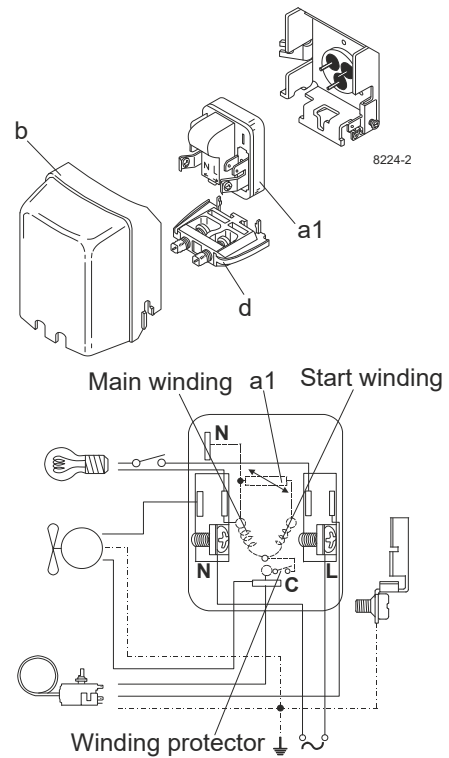

Ambient temperatures / system cooling

Ambient temperature min.:	10°C / 50°F
Ambient temperature max.:	43°C / 110°F

System cooling (n/a: outside limits)			
T ambient	LBP	MBP	HBP
32°C / 90°F	fan 3m/s	fan 3m/s	n/a
38°C / 100°F	fan 3m/s	fan 3m/s	n/a
43°C / 110°F	fan 3m/s	fan 3m/s	n/a

Operation pressure range

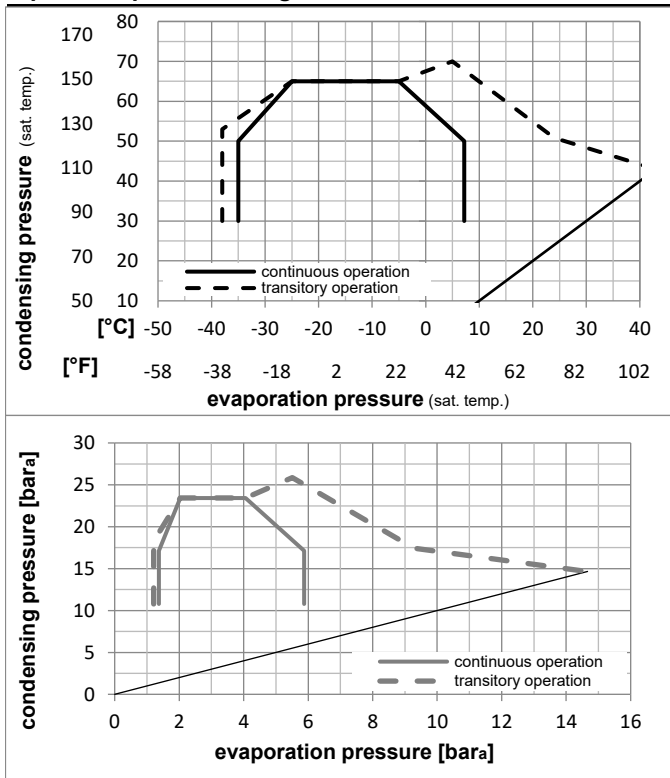

Components

a1	e-PTC starter (220V, 25Ohm, 4.8mm)	103N0050
b	plastic cover	103N0491
d	cord relief	103N1010

Model

Designation **DLE5.7CNT** **220-240V/50Hz** Conf. 3 Sales code: **102H4679**

Optimization + standard conditions

R290, 220V/50Hz, RSIR, fan 3m/s, UL, CCC

		Evaporating pressure (saturation temperature)				Condensing pressure (saturation temperature)						Power consumption			
		Return gas temp.		Liquid temp.		Cooling capacity		COP	EER		P1	I	Ref. mass flow		
		pe	pc	RGT	Tliq	[W]	[Btu/h]	[kcal/h]	[W/W]	[Btu/Wh]	[kcal/Wh]	[W]	[A]	[kg/h]	
[°C]	-23	54	32	32	295,0	1007	253,9	1,45	4,96	1,25	202,9	1,47	2,99	ASHRAE LBP	
[°F]	-10	130	90	90											
[°C]	-25	55	32	55	222,2	759	191,2	1,13	3,85	0,97	197,0	1,45	2,77	cecomaf LBP	
[°F]	-13	131	90	131											
[°C]	-35	40	20	40	166,2	568	143,1	1,13	3,86	0,97	147,0	1,27	1,90	EN12900 LBP	
[°F]	-31	104	68	104											
[°C]	-7	54	35	46	510,4	1743	439,2	1,95	6,66	1,68	261,7	1,71	5,82	ASHRAE MBP	
[°F]	20	130	95	115											
[°C]	-10	55	32	55	406,8	1389	350,1	1,61	5,51	1,39	252,0	1,67	5,15	cecomaf MBP	
[°F]	14	131	90	131											
[°C]	-10	45	20	45	446,8	1526	384,5	1,95	6,67	1,68	228,8	1,57	5,49	EN12900 MBP	
[°F]	14	113	68	113											

Performance tables

R290, 220V/50Hz, RSIR, fan 3m/s, UL, CCC

	pe		Cooling capacity			COP	EER	P1	I	m	
	[°C]	[°F]	[W]	[Btu/h]	[kcal/h]	[W/W]	[Btu/Wh]				[kcal/Wh]
[°C / °F]	-35	-31	159,5	545	137,3	1,06	3,62	0,91	150,3	1,28	1,79
cond. pressure	-23	-10	274,8	939	236,5	1,44	4,92	1,24	190,9	1,43	3,10
pc= 45/113	-15	5	384,5	1313	330,9	1,78	6,09	1,53	215,6	1,52	4,37
return gas temp.	-9	15	474,8	1622	408,7	2,06	7,04	1,78	230,2	1,57	5,44
RGT= 32/90	-4	25	581,9	1987	500,8	2,39	8,17	2,06	243,3	1,63	6,71
liquid temp	0	32	668,0	2281	574,9	2,65	9,06	2,28	251,7	1,66	7,75
Tliq= 45/113	7,2	45	855,6	2922	736,3	3,22	11,01	2,77	265,4	1,72	10,05
[°C / °F]	-35	-31	134,1	458	115,4	0,86	2,94	0,74	155,6	1,29	1,66
cond. pressure	-23	-10	238,9	816	205,6	1,17	4,01	1,01	203,5	1,48	2,98
pc= 55/131	-15	5	335,9	1147	289,1	1,43	4,89	1,23	234,6	1,60	4,22
return gas temp	-9	15	415,4	1418	357,5	1,64	5,59	1,41	253,9	1,68	5,26
RGT= 32/90	-4	25	509,5	1740	438,5	1,87	6,39	1,61	272,1	1,76	6,50
liquid temp	0	32	585,5	2000	503,9	2,06	7,03	1,77	284,3	1,81	7,52
Tliq= 55/131	7,2	45	751,7	2567	646,9	2,46	8,40	2,12	305,7	1,91	9,79

Model

Designation	DLE5.7CNT	208-230V/60Hz	Conf. 4	Sales code:	102H4679
-------------	------------------	----------------------	----------------	-------------	-----------------

Configuration

Motorconfiguration	RSCR	
Power supply (nominal)	208-230V/60Hz 1~	
Refrigerant	R290	
Application	LBP+MBP	
Voltage range	187-253V	
Starting torque	LST	
Approvals	UL	SA3693
	CCC	

Electrical accessories / wiring diagram

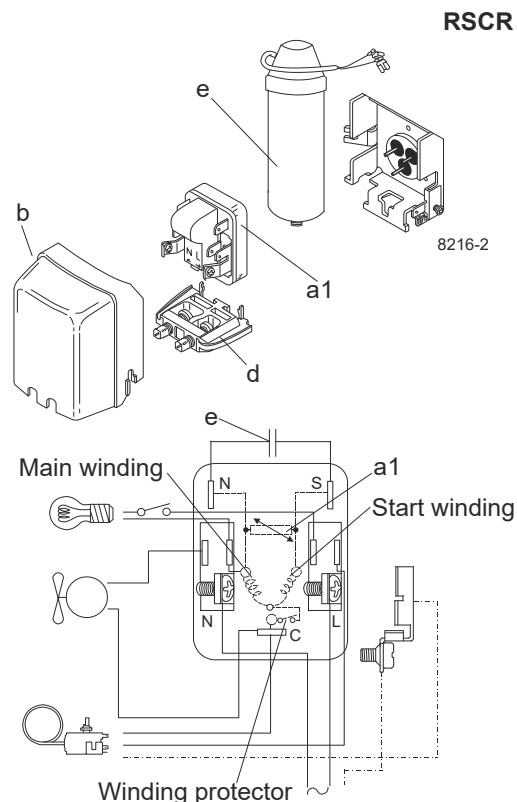

Ambient temperatures / system cooling

Ambient temperature min.:	10°C / 50°F
Ambient temperature max.:	43°C / 110°F

System cooling (n/a: outside limits)			
T ambient	LBP	MBP	HBP
32°C / 90°F	fan 3m/s	fan 3m/s	n/a
38°C / 100°F	fan 3m/s	fan 3m/s	n/a
43°C / 110°F	fan 3m/s	fan 3m/s	n/a

Operation pressure range

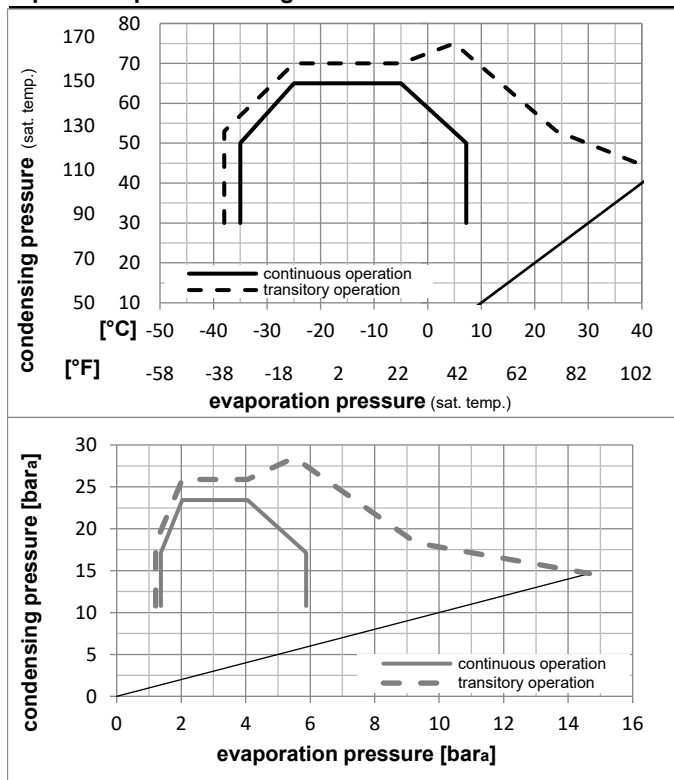

Components

a1	e-PTC starter (220V, 250hm, 4.8mm)	103N0050
e	run capacitor (5μF, 4.8mm)	117-7129
b	plastic cover	103N0491
d	cord relief bracket for run capacitor	103N1010
	screw M4x8mm	117-0301

Model

Designation **DLE5.7CNT** **208-230V/60Hz** Conf. 4 Sales code: **102H4679**

Optimization + standard conditions

R290, 230V/60Hz, RSCR, fan 3m/s, UL, CCC

		Evaporating pressure (saturation temperature)			Condensing pressure (saturation temperature)			Return gas temp.			Liquid temp.			Cooling capacity			COP	EER	Power consumption		
		pe	pc	RGT	Tliq	[W]	[Btu/h]	[kcal/h]	[W/W]	[Btu/Wh]	[kcal/Wh]	[W]	I	m	[W]	[A]	[kg/h]	Current consumption			
[°C]	[°F]																	Ref. mass flow			
[°C]	-23	54	32	32	352,9	1205	303,7	1,63	5,57	1,40	216,4	1,08	3,57	ASHRAE LBP							
[°F]	-10	130	90	90																	
[°C]	-25	55	32	55	265,6	907	228,6	1,27	4,33	1,09	209,7	1,06	3,31	cecomaf LBP							
[°F]	-13	131	90	131																	
[°C]	-35	40	20	40	198,8	679	171,1	1,27	4,32	1,09	157,0	0,95	2,27	EN12900 LBP							
[°F]	-31	104	68	104																	
[°C]	-7	54	35	46	612,4	2091	527,0	2,12	7,25	1,83	288,4	1,28	6,99	ASHRAE MBP							
[°F]	20	130	95	115																	
[°C]	-10	55	32	55	488,2	1667	420,1	1,77	6,05	1,52	275,7	1,24	6,17	cecomaf MBP							
[°F]	14	131	90	131																	
[°C]	-10	45	20	45	536,0	1830	461,3	2,14	7,31	1,84	250,4	1,17	6,58	EN12900 MBP							
[°F]	14	113	68	113																	

Performance tables

R290, 230V/60Hz, RSCR, fan 3m/s, UL, CCC

	pe		Cooling capacity			COP	EER	P1			I	m
	[°C]	[°F]	[W]	[Btu/h]	[kcal/h]	[W/W]	[Btu/Wh]	[kcal/Wh]	[W]	[A]	[kg/h]	
[°C / °F]	-35	-31	190,9	652	164,3	1,19	4,06	1,02	160,5	0,95	2,14	
cond. pressure	-23	-10	328,9	1123	283,1	1,61	5,51	1,39	203,7	1,05	3,71	
pc= 45/113	-15	5	461,1	1575	396,8	1,98	6,75	1,70	233,4	1,12	5,25	
return gas temp.	-9	15	569,7	1946	490,3	2,26	7,71	1,94	252,2	1,18	6,52	
RGT= 32/90	-4	25	697,6	2382	600,4	2,59	8,83	2,22	269,9	1,23	8,04	
liquid temp	0	32	800,1	2732	688,5	2,84	9,71	2,45	281,4	1,26	9,28	
Tliq= 45/113	7,2	45	1021,8	3490	879,4	3,40	11,60	2,92	300,8	1,33	12,01	
[°C / °F]	-35	-31	160,6	548	138,2	0,97	3,31	0,83	165,8	0,96	1,99	
cond. pressure	-23	-10	285,9	976	246,0	1,32	4,50	1,13	217,0	1,08	3,56	
pc= 55/131	-15	5	402,8	1376	346,7	1,59	5,42	1,37	253,9	1,18	5,06	
return gas temp	-9	15	498,4	1702	429,0	1,79	6,12	1,54	278,1	1,25	6,31	
RGT= 32/90	-4	25	611,1	2087	525,9	2,03	6,92	1,74	301,7	1,32	7,80	
liquid temp	0	32	701,6	2396	603,8	2,21	7,54	1,90	317,7	1,38	9,01	
Tliq= 55/131	7,2	45	898,0	3067	772,9	2,59	8,86	2,23	346,1	1,47	11,70	

Model

Designation	DLE5.7CNT	220-240V/50Hz	Conf. 5	Sales code:	102H4679
-------------	------------------	----------------------	----------------	-------------	-----------------

Configuration

Motorconfiguration	RSCR	
Power supply (nominal)	220-240V/50Hz 1~	
Refrigerant	R290	
Application	LBP+MBP	
Voltage range	187-254V	
Starting torque	LST	
Approvals	UL	SA3693
	CCC	

Electrical accessories / wiring diagram

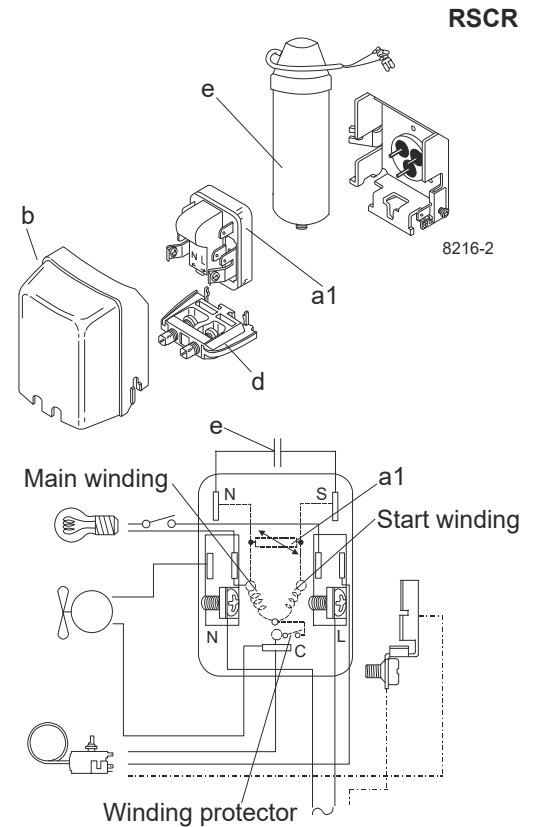

Ambient temperatures / system cooling

Ambient temperature min.:	10°C / 50°F
Ambient temperature max.:	43°C / 110°F

System cooling (n/a: outside limits)			
T ambient	LBP	MBP	HBP
32°C / 90°F	fan 3m/s	fan 3m/s	n/a
38°C / 100°F	fan 3m/s	fan 3m/s	n/a
43°C / 110°F	fan 3m/s	fan 3m/s	n/a

Operation pressure range

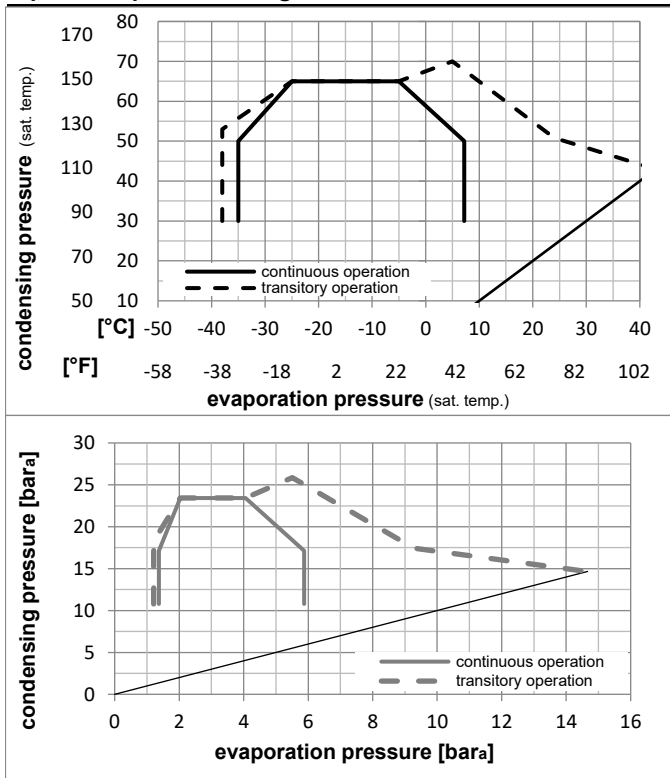

Components

a1	e-PTC starter (220V, 250hm, 4.8mm)	103N0050
e	run capacitor (5μF, 4.8mm)	117-7129
b	plastic cover	103N0491
d	cord relief bracket for run capacitor	103N1010
	screw M4x8mm	117-0301

Model

Designation **DLE5.7CNT** **220-240V/50Hz** Conf. 5 Sales code: **102H4679**

Optimization + standard conditions

R290, 220V/50Hz, RSCR, fan 3m/s, UL, CCC

		Evaporating pressure (saturation temperature)				Condensing pressure (saturation temperature)						Power consumption			
		Return gas temp.		Liquid temp.		Cooling capacity		COP	EER		P1	I	Ref. mass flow		
		pe	pc	RGT	Tliq	[W]	[Btu/h]	[kcal/h]	[W/W]	[Btu/Wh]	[kcal/Wh]	[W]	[A]	[kg/h]	
[°C]	-23	54	32	32	295,1	1008	253,9	1,49	5,10	1,28	197,7	1,44	2,99	ASHRAE LBP	
[°F]	-10	130	90	90											
[°C]	-25	55	32	55	222,2	759	191,3	1,16	3,95	1,00	192,1	1,42	2,77	cecomaf LBP	
[°F]	-13	131	90	131											
[°C]	-35	40	20	40	166,3	568	143,1	1,15	3,93	0,99	144,5	1,27	1,90	EN12900 LBP	
[°F]	-31	104	68	104											
[°C]	-7	54	35	46	510,7	1744	439,6	2,02	6,89	1,74	253,2	1,64	5,83	ASHRAE MBP	
[°F]	20	130	95	115											
[°C]	-10	55	32	55	407,0	1390	350,3	1,67	5,70	1,44	244,1	1,60	5,15	cecomaf MBP	
[°F]	14	131	90	131											
[°C]	-10	45	20	45	447,0	1527	384,7	2,01	6,87	1,73	222,1	1,51	5,49	EN12900 MBP	
[°F]	14	113	68	113											

Performance tables

R290, 220V/50Hz, RSCR, fan 3m/s, UL, CCC

	pe		Cooling capacity			COP	EER	P1	I	m	
	[°C]	[°F]	[W]	[Btu/h]	[kcal/h]	[W/W]	[Btu/Wh]				[kcal/Wh]
[°C / °F]	-35	-31	159,6	545	137,3	1,08	3,69	0,93	147,7	1,28	1,79
cond. pressure	-23	-10	274,9	939	236,6	1,48	5,04	1,27	186,3	1,40	3,10
pc= 45/113	-15	5	384,6	1314	331,0	1,83	6,27	1,58	209,7	1,47	4,38
return gas temp.	-9	15	475,1	1623	408,9	2,13	7,26	1,83	223,5	1,52	5,44
RGT= 32/90	-4	25	582,2	1988	501,1	2,47	8,43	2,12	235,9	1,56	6,71
liquid temp	0	32	668,4	2283	575,3	2,74	9,37	2,36	243,8	1,59	7,75
Tliq= 45/113	7,2	45	856,2	2924	736,8	3,34	11,39	2,87	256,7	1,64	10,06
[°C / °F]	-35	-31	134,2	458	115,5	0,88	3,00	0,76	152,7	1,29	1,66
cond. pressure	-23	-10	239,0	816	205,7	1,21	4,12	1,04	198,2	1,44	2,98
pc= 55/131	-15	5	336,1	1148	289,2	1,48	5,04	1,27	227,6	1,54	4,23
return gas temp	-9	15	415,6	1419	357,7	1,69	5,77	1,46	245,8	1,61	5,26
RGT= 32/90	-4	25	509,9	1742	438,9	1,94	6,62	1,67	263,0	1,68	6,51
liquid temp	0	32	586,0	2001	504,3	2,13	7,29	1,84	274,5	1,72	7,53
Tliq= 55/131	7,2	45	752,4	2570	647,6	2,55	8,72	2,20	294,6	1,81	9,80