

**Model**

Designation	<b>DLE6.5CN</b>	<b>115-127V/60Hz 1~</b>	Sales code:	<b>102H3792</b>
-------------	-----------------	-------------------------	-------------	-----------------

**Compressor design**

Oil type	Polyolester	Refrigerant(s)	<b>R290</b>
Oil viscosity	32cSt	Displacement	6,5cm <sup>3</sup> / 0,4cu.in
Oil quantity	221cm <sup>3</sup> / 7,5fl.oz	Compressors on pallet	100
Refr. charge - tech. limit	150g / 5,3oz		
Free gas volume comp.	1325cm <sup>3</sup> / 44,8fl.oz		
Weight	8,5kg / 18,7lbs		
Motor protection	1# internal		
Winding resistance main	2,47Ω (at 25°C)		
Winding resistance aux	5Ω (at 25°C)		
Max. winding temp.	125°C / 257°F		
Max. discharge temp.	130°C / 266°F		



**General - Configurations with DLE6.5CN**

	<b>Conf. 1</b>	<b>Conf. 2</b>	<b>Conf. 3</b>
Motorconfiguration	CSIR	RSIR	RSCR
Power supply (nominal)	115-127V/60Hz	115-127V/60Hz	115-127V/60Hz
Number of phases	1	1	1
Voltage range	95-135V	95-135V	95-135V
Approvals	UL, CCC, EAC	UL, CCC, EAC	UL, CCC, EAC
Starting torque	HST	LST	LST
Note	- / -		

**Applications with DLE6.5CN**

	<b>Conf. 1</b>	<b>Conf. 2</b>	<b>Conf. 3</b>
Refrigerant	R290	R290	R290
Application	LBP+MBP	LBP+MBP	LBP+MBP
System cooling	fan 3m/s	fan 3m/s	fan 3m/s
Hot gas defrost	OK	OK	OK
Long interval pull down	OK	OK	OK

**Electrical data - Configurations with DLE6.5CN**

	<b>Conf. 1</b>	<b>Conf. 2</b>	<b>Conf. 3</b>
Starting device type	relay	PTC	PTC
Run capacitor	-/-	-/-	15μF
Start capacitor	240μF	-/-	-/-
LRA (locked rotor amps / 4s)	16,68A	20,07A	19,48A
RLA (rated load amps / 1s)	3,96A	3,96A	3,1A
Cut in current	28,82A	20,07A	28,82A
IP class	21	21	21

**Model**

Designation	<b>DLE6.5CN</b>	115-127V/60Hz 1~	Sales code:	<b>102H3792</b>
-------------	-----------------	------------------	-------------	-----------------

**Compressor dimensions**

<b>Housing</b>	A Height	174mm / 6,85in
	B Height	168mm / 6,61in
	C Length shell	183mm / 7,2in
	D Length w. cover	232mm / 9,13in
	E Width	156mm / 6,14in

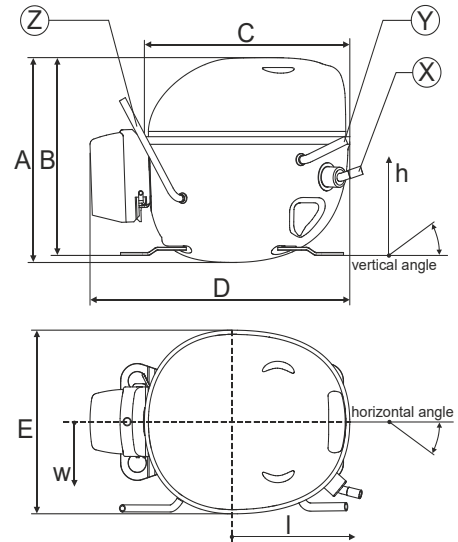

Connectors		Suction	Discharge	Process
		X	Y	Z
Diameter	[mm]	øi 8,11-8,29	øi 6,41-6,59	øi 6,4-6,6
	(i:inside, o:outside) [in]	øi 0,32-0,33	øi 0,25-0,26	øi 0,25-0,26
Material		copper	copper	copper
Horizontal angle	±2°	10°	0°	0°
Vertical angle	±2°	18°	25°	119°
Position l/h/w	[mm]	135/77/67	98/96/72	-98/133/73
	[in]	5,3/3/2,6	3,8/3,8/2,8	-3,9/5,2/2,9
Straight tube l.	[mm]	12	12	12
	[in]	0,5	0,5	0,5

**Compressor fixation**

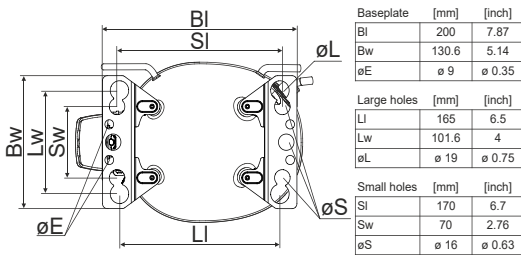

**Bolt joint**

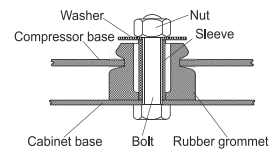

**Snap-on**

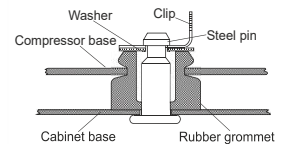

Mounting accessories	one comp.	multi pack
Bolt joint   M6   ø16mm	118-1917	118-1918
Bolt joint   ø1/4"   ø16mm	118-1946	
Bolt joint   ø1/4"   ø19mm	118-1949	
Snap-on   ø7,3   ø16mm	118-1947	118-1919

**Model**

Designation	<b>DLE6.5CN</b>	<b>115-127V/60Hz</b>	<b>Conf. 1</b>	Sales code:	<b>102H3792</b>
-------------	-----------------	----------------------	----------------	-------------	-----------------

**Configuration**

Motorconfiguration	CSIR	
Power supply (nominal)	115-127V/60Hz 1~	
Refrigerant	R290	
Application	LBP+MBP	
Voltage range	95-135V	
Starting torque	HST	
Approvals	UL	SA3693
	CCC	
	EAC	

**Electrical accessories / wiring diagram**

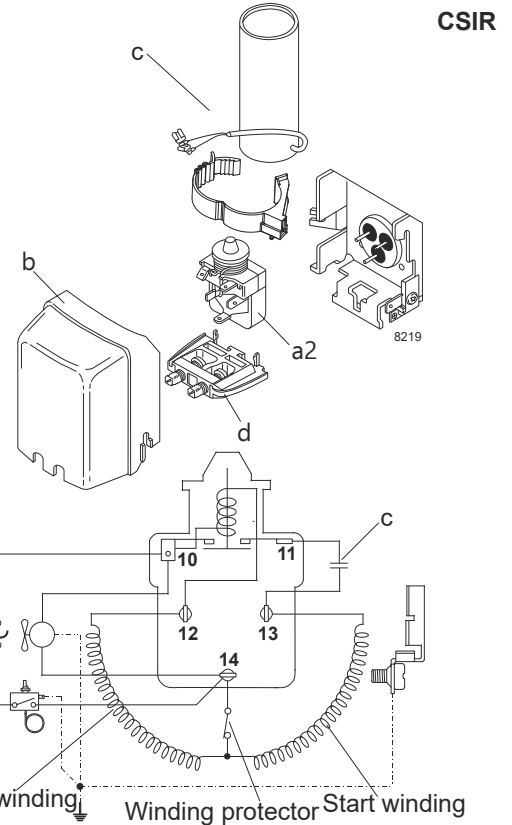

**Ambient temperatures / system cooling**

Ambient temperature min.:	10°C / 50°F
Ambient temperature max.:	43°C / 110°F

System cooling (n/a: outside limits)			
T ambient	LBP	MBP	HBP
32°C / 90°F	fan 3m/s	fan 3m/s	n/a
38°C / 100°F	fan 3m/s	fan 3m/s	n/a
43°C / 110°F	fan 3m/s	fan 3m/s	n/a

**Operation pressure range**

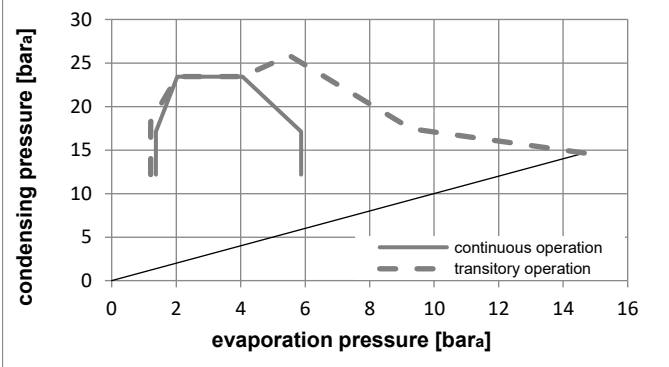
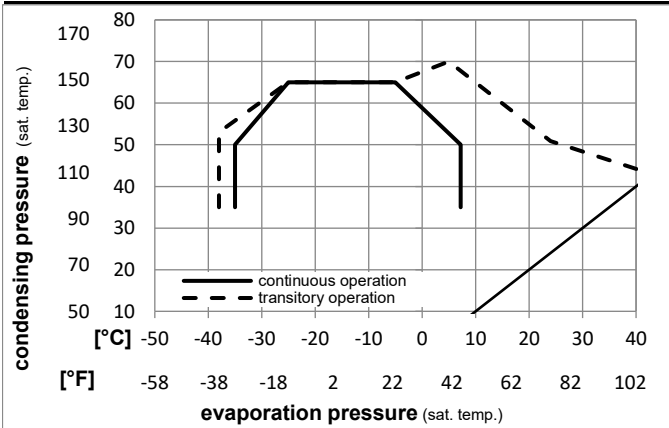

**Components**

a2	relay	117U7013
c	start capacitor (240µF)	117U5023
b	plastic cover	103N0492
d	cord relief	103N1010

**Model**

Designation **DLE6.5CN 115-127V/60Hz** Conf. 1 Sales code: **102H3792**

**Optimization + standard conditions**

115-127V/60Hz 1~, CSIR, fan 3m/s, UL, CCC, EAC

	Evaporating pressure (saturation temperature)				Condensing pressure (saturation temperature)						Power consumption			ASHRAE LBP				
	pe	pc	RGT	Tliq	Cooling capacity			COP	EER		P1	I	Ref. mass flow					
	[°C]	[°F]	[°C]	[°F]	[W]	[Btu/h]	[kcal/h]	[W/W]	[Btu/Wh]	[kcal/Wh]	[W]	[A]	[kg/h]					
	-23,3	-10	54,4	130	32,2	90	32,2	90	375,7	1283	323,4	1,50	5,11	1,29	250,9	3,14	3,81	
	-25	-13	55	131	32	89,6	55	131	281,9	963	242,6	1,16	3,97	1,00	242,5	3,09	3,51	cecomaf LBP
	-35	-31	40	104	20	68	40	104	213,3	728	183,5	1,15	3,94	0,99	184,7	2,80	2,44	EN12900 LBP
	-6,66	20	54,4	130	35	95	46,1	115	669,7	2287	576,3	1,96	6,69	1,69	341,8	3,77	7,64	ASHRAE MBP
	-10	14	55	131	32	89,6	55	131	530,3	1811	456,4	1,63	5,57	1,40	325,0	3,65	6,71	cecomaf MBP
	-10	14	45	113	20	68	45	113	592,4	2023	509,8	1,98	6,78	1,71	298,4	3,47	7,27	EN12900 MBP

**Performance tables**

115-127V/60Hz 1~, CSIR, fan 3m/s, UL, CCC, EAC

	pe	Cooling capacity			COP	EER		P1	I	m	
	[°C]	[°F]	[W]	[Btu/h]	[kcal/h]	[W/W]	[Btu/Wh]	[kcal/Wh]	[W]	[A]	[kg/h]
[°C / °F]	-35	-31	201,9	690	173,8	1,08	3,69	0,93	187,0	2,81	2,26
cond. pressure	-23,3	-10	358,3	1224	308,3	1,50	5,11	1,29	239,4	3,08	4,05
pc= 45/113	-15	5	506,6	1730	436,0	1,83	6,26	1,58	276,4	3,31	5,76
return gas temp.	-9,4	15	630,0	2152	542,2	2,09	7,15	1,80	300,9	3,49	7,21
RGT= 32/90	-3,9	25	777,6	2656	669,2	2,39	8,17	2,06	325,2	3,67	8,97
liquid temp	0	32	897,5	3065	772,4	2,62	8,96	2,26	342,2	3,80	10,41
Tliq= 45/113	7,2	45	1161,1	3965	999,2	3,11	10,61	2,67	373,7	4,06	13,64
[°C / °F]	-35	-31	165,1	564	142,1	0,88	2,99	0,75	188,3	2,81	2,04
cond. pressure	-23,3	-10	304,2	1039	261,8	1,21	4,13	1,04	251,6	3,15	3,79
pc= 55/131	-15	5	433,9	1482	373,5	1,46	4,98	1,26	297,4	3,45	5,46
return gas temp	-9,4	15	542,0	1851	466,5	1,65	5,64	1,42	328,1	3,67	6,86
RGT= 32/90	-3,9	25	671,9	2295	578,3	1,87	6,39	1,61	359,1	3,91	8,57
liquid temp	0	32	778,0	2657	669,5	2,04	6,97	1,76	381,0	4,08	9,99
Tliq= 55/131	7,2	45	1013,0	3460	871,8	2,40	8,20	2,07	421,9	4,43	13,20

**Model**

Designation	<b>DLE6.5CN</b>	<b>115-127V/60Hz</b>	<b>Conf. 2</b>	Sales code:	<b>102H3792</b>
-------------	-----------------	----------------------	----------------	-------------	-----------------

**Configuration**

Motorconfiguration	RSIR
Power supply (nominal)	115-127V/60Hz 1~
Refrigerant	R290
Application	LBP+MBP
Voltage range	95-135V
Starting torque	LST
Approvals	UL SA3693
	CCC
	EAC

**Electrical accessories / wiring diagram**

RSIR

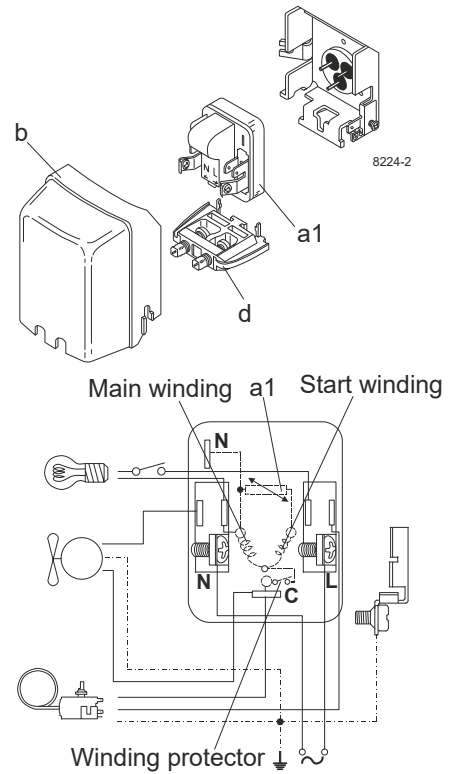

**Ambient temperatures / system cooling**

Ambient temperature min.:	10°C / 50°F
Ambient temperature max.:	43°C / 110°F

System cooling (n/a: outside limits)			
T ambient	LBP	MBP	HBP
32°C / 90°F	fan 3m/s	fan 3m/s	n/a
38°C / 100°F	fan 3m/s	fan 3m/s	n/a
43°C / 110°F	fan 3m/s	fan 3m/s	n/a

**Operation pressure range**

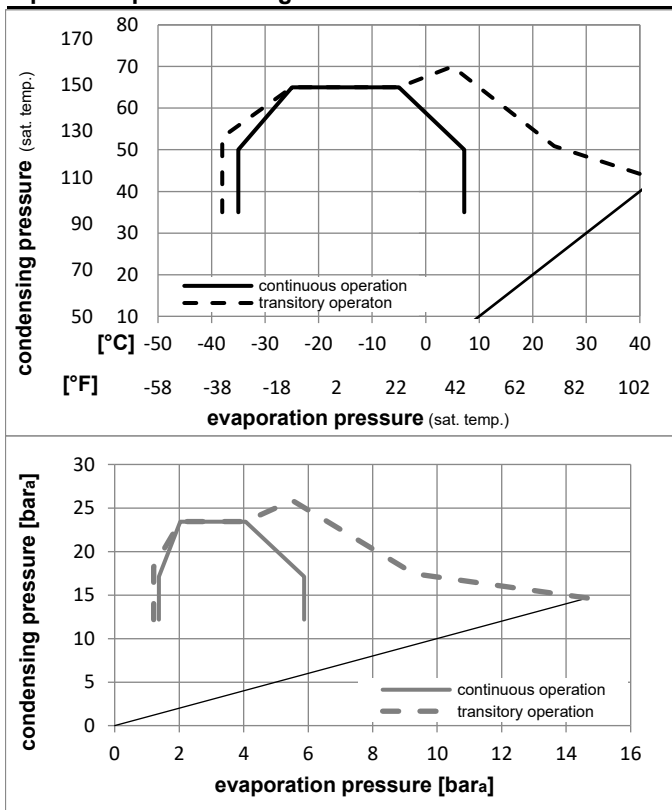

**Components**

a1	e-PTC starter	103N0058
b	plastic cover	103N0492
d	cord relief	103N1010

**Alternative components**

a1	e-PTC starter (115V, 50Ohm, 6.3mm, 4.8-cap)	103N0057
b	plastic cover	103N0492
d	cord relief	103N1010

**Model**

Designation **DLE6.5CN 115-127V/60Hz** Conf. **2** Sales code: **102H3792**

**Optimization + standard conditions**

115-127V/60Hz 1~, RSIR, fan 3m/s, UL, CCC, EAC

	Evaporating pressure (saturation temperature)				Condensing pressure (saturation temperature)						Power consumption			ASHRAE LBP
	pe	pc	RGT	Tliq	Cooling capacity			COP	EER	P1	I	Ref. mass flow		
	[°C]	[°C]	[°C]	[°C]	[W]	[Btu/h]	[kcal/h]	[W/W]	[Btu/Wh]	[kcal/Wh]	[W]	[A]	[kg/h]	
	-23,3	54,4	32,2	32,2	375,7	1283	323,4	1,50	5,11	1,29	250,9	3,14	3,81	ASHRAE LBP
	[-10]	130	90	90										
	-25	55	32	55	281,9	963	242,6	1,16	3,97	1,00	242,5	3,09	3,51	cecomaf LBP
	[-13]	131	89,6	131										
	-35	40	20	40	213,3	728	183,5	1,15	3,94	0,99	184,7	2,80	2,44	EN12900 LBP
	[-31]	104	68	104										
	-6,66	54,4	35	46,1	669,7	2287	576,3	1,96	6,69	1,69	341,8	3,77	7,64	ASHRAE MBP
	[20]	130	95	115										
	-10	55	32	55	530,3	1811	456,4	1,63	5,57	1,40	325,0	3,65	6,71	cecomaf MBP
	[14]	131	89,6	131										
	-10	45	20	45	592,4	2023	509,8	1,98	6,78	1,71	298,4	3,47	7,27	EN12900 MBP
	[14]	113	68	113										

**Performance tables**

115-127V/60Hz 1~, RSIR, fan 3m/s, UL, CCC, EAC

	pe	Cooling capacity			COP	EER	P1	I	m		
	[°C]	[°F]	[W]	[Btu/h]	[kcal/h]	[W/W]	[Btu/Wh]	[kcal/Wh]	[W]	[A]	[kg/h]
[°C / °F]	-35	-31	201,9	690	173,8	1,08	3,69	0,93	187,0	2,81	2,26
cond. pressure	-23,3	-10	358,3	1224	308,3	1,50	5,11	1,29	239,4	3,08	4,05
pc= 45/113	-15	5	506,6	1730	436,0	1,83	6,26	1,58	276,4	3,31	5,76
return gas temp.	-9,4	15	630,0	2152	542,2	2,09	7,15	1,80	300,9	3,49	7,21
RGT= 32/90	-3,9	25	777,6	2656	669,2	2,39	8,17	2,06	325,2	3,67	8,97
liquid temp	0	32	897,5	3065	772,4	2,62	8,96	2,26	342,2	3,80	10,41
Tliq= 45/113	7,2	45	1161,1	3965	999,2	3,11	10,61	2,67	373,7	4,06	13,64
[°C / °F]	-35	-31	165,1	564	142,1	0,88	2,99	0,75	188,3	2,81	2,04
cond. pressure	-23,3	-10	304,2	1039	261,8	1,21	4,13	1,04	251,6	3,15	3,79
pc= 55/131	-15	5	433,9	1482	373,5	1,46	4,98	1,26	297,4	3,45	5,46
return gas temp	-9,4	15	542,0	1851	466,5	1,65	5,64	1,42	328,1	3,67	6,86
RGT= 32/90	-3,9	25	671,9	2295	578,3	1,87	6,39	1,61	359,1	3,91	8,57
liquid temp	0	32	778,0	2657	669,5	2,04	6,97	1,76	381,0	4,08	9,99
Tliq= 55/131	7,2	45	1013,0	3460	871,8	2,40	8,20	2,07	421,9	4,43	13,20

**Model**

Designation	<b>DLE6.5CN</b>	<b>115-127V/60Hz</b>	<b>Conf. 3</b>	Sales code:	<b>102H3792</b>
-------------	-----------------	----------------------	----------------	-------------	-----------------

**Configuration**

Motorconfiguration	RSCR
Power supply (nominal)	115-127V/60Hz 1~
Refrigerant	R290
Application	LBP+MBP
Voltage range	95-135V
Starting torque	LST
Approvals	UL SA3693
	CCC
	EAC

**Electrical accessories / wiring diagram**

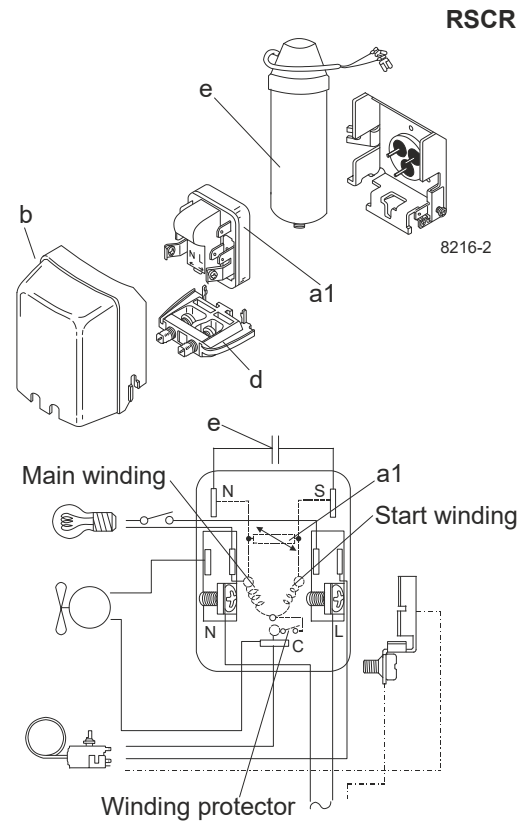

**Ambient temperatures / system cooling**

Ambient temperature min.:	10°C / 50°F
Ambient temperature max.:	43°C / 110°F

System cooling (n/a: outside limits)			
T ambient	LBP	MBP	HBP
32°C / 90°F	fan 3m/s	fan 3m/s	n/a
38°C / 100°F	fan 3m/s	fan 3m/s	n/a
43°C / 110°F	fan 3m/s	fan 3m/s	n/a

**Operation pressure range**

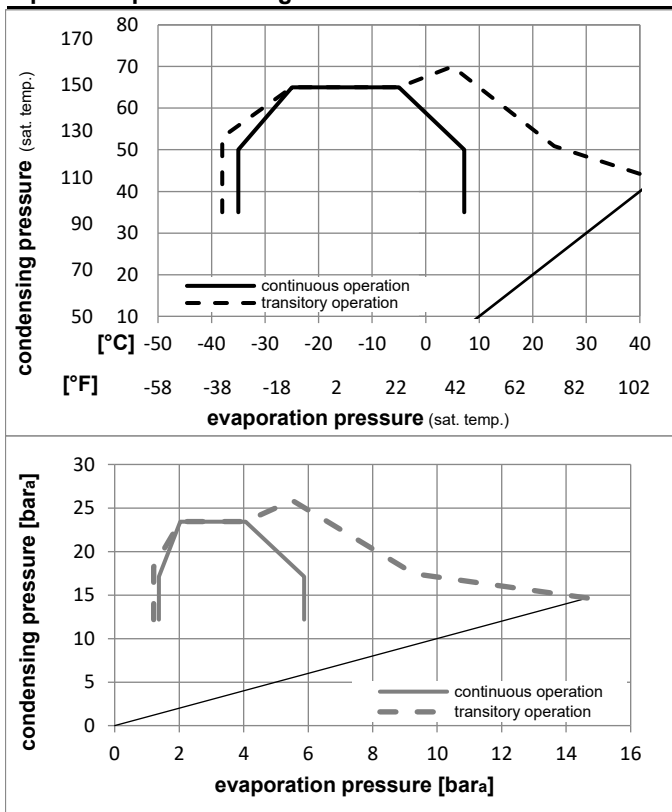

**Components**

a1	e-PTC starter	103N0058
e	run capacitor (15µF, 6.3mm)	117-7118
b	plastic cover	103N0492
d	cord relief	103N1010
	bracket for run capacitor	117-0300
	screw M4x8mm	117-0301

**Alternative components**

a1	e-PTC starter (115V, 50Ohm, 6.3mm, 4.8-cap)	103N0057
e	run capacitor (15µF, 4.8mm)	117-7120
b	plastic cover	103N0492
d	cord relief	103N1010
	bracket for run capacitor	117-0300
	screw M4x8mm	117-0301

**Model**

Designation	<b>DLE6.5CN</b>	<b>115-127V/60Hz</b>	<b>Conf. 3</b>	Sales code:	<b>102H3792</b>
-------------	-----------------	----------------------	----------------	-------------	-----------------

**Optimization + standard conditions**

115-127V/60Hz 1~, RSCR, fan 3m/s, UL, CCC, EAC

	Evaporating pressure (saturation temperature)				Condensing pressure (saturation temperature)						Power consumption			ASHRAE LBP
	pe	pc	RGT	Tliq	Cooling capacity			COP	EER	P1	I	Ref. mass flow		
	[°C]	[°C]	[°C]	[°C]	[W]	[Btu/h]	[kcal/h]	[W/W]	[Btu/Wh]	[kcal/Wh]	[W]	[A]	[kg/h]	
	-23,3	54,4	32,2	32,2	381,6	1303	328,4	1,60	5,48	1,38	237,9	2,98	3,86	ASHRAE LBP
	[-10]	130	90	90										
	-25	55	32	55	286,3	978	246,4	1,24	4,25	1,07	230,0	2,93	3,57	cecomaf LBP
	[-13]	131	89,6	131										
	-35	40	20	40	217,4	743	187,1	1,24	4,23	1,07	175,4	2,66	2,48	EN12900 LBP
	[-31]	104	68	104										
	-6,66	54,4	35	46,1	677,4	2313	582,9	2,11	7,19	1,81	321,8	3,55	7,73	ASHRAE MBP
	[20]	130	95	115										
	-10	55	32	55	537,2	1835	462,3	1,75	5,98	1,51	306,6	3,44	6,80	cecomaf MBP
	[14]	131	89,6	131										
	-10	45	20	45	600,0	2049	516,4	2,13	7,28	1,83	281,5	3,27	7,37	EN12900 MBP
	[14]	113	68	113										

**Performance tables**

115-127V/60Hz 1~, RSCR, fan 3m/s, UL, CCC, EAC

	pe	Cooling capacity			COP	EER	P1	I	m		
	[°C]	[°F]	[W]	[Btu/h]	[kcal/h]	[W/W]	[Btu/Wh]	[kcal/Wh]	[W]	[A]	[kg/h]
[°C / °F]	-35	-31	206,0	703	177,2	1,16	3,96	1,00	177,7	2,67	2,31
cond. pressure	-23,3	-10	364,1	1243	313,3	1,60	5,48	1,38	226,9	2,92	4,11
pc= 45/113	-15	5	514,1	1756	442,5	1,97	6,72	1,69	261,3	3,13	5,85
return gas temp.	-9,4	15	638,0	2179	549,1	2,25	7,68	1,94	283,8	3,29	7,30
RGT= 32/90	-3,9	25	785,1	2681	675,7	2,57	8,77	2,21	305,7	3,45	9,05
liquid temp	0	32	903,8	3087	777,8	2,82	9,63	2,43	320,7	3,56	10,48
Tliq= 45/113	7,2	45	1162,8	3971	1000,7	3,34	11,42	2,88	347,7	3,78	13,66
[°C / °F]	-35	-31	168,5	575	145,0	0,94	3,22	0,81	178,9	2,67	2,08
cond. pressure	-23,3	-10	308,9	1055	265,9	1,29	4,42	1,11	238,6	2,98	3,85
pc= 55/131	-15	5	440,3	1504	378,9	1,57	5,35	1,35	281,2	3,26	5,54
return gas temp	-9,4	15	549,0	1875	472,5	1,77	6,06	1,53	309,4	3,46	6,95
RGT= 32/90	-3,9	25	678,6	2317	584,0	2,01	6,87	1,73	337,4	3,67	8,66
liquid temp	0	32	783,6	2676	674,4	2,20	7,50	1,89	356,9	3,83	10,07
Tliq= 55/131	7,2	45	1014,5	3465	873,1	2,58	8,83	2,22	392,5	4,12	13,22