

Model

Designation	FR7GH	220-240V/50Hz 1~ 220-240V/60Hz 1~	Sales code:	103G6692
-------------	--------------	--	-------------	-----------------

Compressor design

Oil type	Polyolester	Refrigerant(s)	R134a
Oil viscosity	19,2cST	Displacement	6,93cm ³ / 0,42cu.in
Oil quantity	445cm ³ / 15,1fl.oz	Compressors on pallet	80
Refr. charge - tech. limit	900g / 31,7oz		
Free gas volume comp.	1350cm ³ / 45,6fl.oz		
Weight	10,6kg / 23,4lbs		
Motor protection	1# internal		
Winding resistance main	8,8Ω (at 25°C)		
Winding resistance aux	12Ω (at 25°C)		
Max. winding temp.	125°C / 257°F		
Max. discharge temp.	130°C / 266°F		



General - Configurations with FR7GH

	Conf. 1	Conf. 2	Conf. 3	Conf. 4
Motorconfiguration	CSIR	CSIR	CSIR	CSIR
Power supply (nominal)	220-240V/50Hz	220-240V/50Hz	208-230V/60Hz	208-230V/60Hz
Number of phases	1	1	1	1
Voltage range	198-254V	198-254V	198-254V	198-254V
Approvals	CCC	CCC	CCC	CCC
Starting torque	HST	HST	HST	HST
Note	Compressor with oil cooler.			

Applications with FR7GH

	Conf. 1	Conf. 2	Conf. 3	Conf. 4
Refrigerant	R134a	R513A	R134a	R513A
Application	MBP+HBP	MBP+HBP	MBP+HBP	MBP+HBP
System cooling	oil cooled	oil cooled	oil cooled	oil cooled
Hot gas defrost	OK	OK	OK	OK
Long interval pull down	OK	OK	OK	OK

Electrical data - Configurations with FR7GH

	Conf. 1	Conf. 2	Conf. 3	Conf. 4
Starting device type	relay	relay	relay	relay
Run capacitor	-/-	-/-	-/-	-/-
Start capacitor	80μF	80μF	80μF	80μF
LRA (locked rotor amps / 4s)	9,1A	9,1A	9,1A	9,1A
RLA (rated load amps / 1s)				
Cut in current	9,1A	9,1A	9,1A	9,1A
IP class	21	21	21	21

Model

Designation	FR7GH	220-240V/50Hz 1~ 220-240V/60Hz 1~	Sales code:	103G6692
-------------	--------------	-----------------------------------	-------------	-----------------

Compressor dimensions

Housing	A Height	196mm / 7,72in
	B Height	191mm / 7,52in
	C Length shell	220mm / 8,66in
	D Length w. cover	243mm / 9,57in
	E Width	156mm / 6,14in

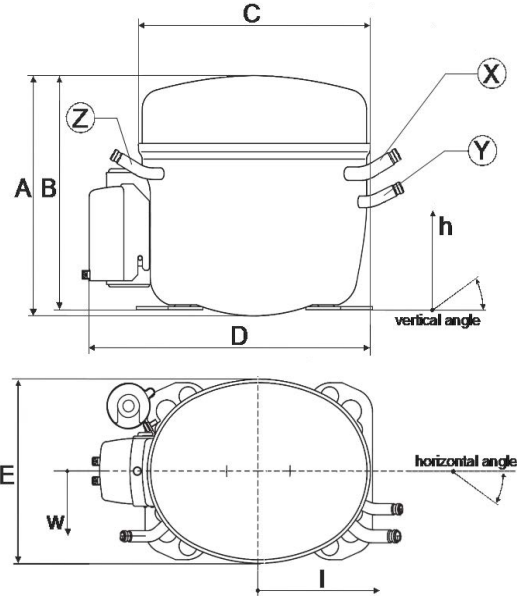

Connectors		Suction		Discharge		Process	
		X	Y	Z	Z		
Diameter	[mm]	øi 8,11-8,29	øi 8,11-8,29	øi 6,11-6,29			
(i:inside, o:outside)	[in]	øi 0,32-0,33	øi 0,32-0,33	øi 0,24-0,25			
Material		steel/CU	copper	steel/CU			
Horizontal angle	±2°	0°	0°	0°			
Vertical angle	±2°	30°	25°	150°			
Position l/h/w	[mm]	125/130/55	128/102/32	-123/127/55			
	[in]	4,9/5,1/2,2	5/4/1,3	-4,8/5/2,2			
Straight tube l.	[mm]	12	12	12			
	[in]	0,5	0,5	0,5			

Compressor fixation

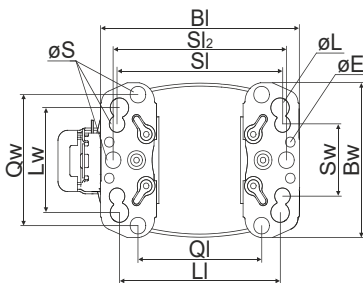

Baseplate	[mm]	[inch]
BI	204	8.03
Bw	150	5.9
øE	ø 9.7	ø 0.38
Large holes		
LI	165	6.5
Lw	101.6	4
øL	ø 19	ø 0.75
Small holes		
SI	170	6.7
Sw	70	2.76
øS	ø 16	ø 0.63
QI	127	5
Qw	127	5

Bolt joint

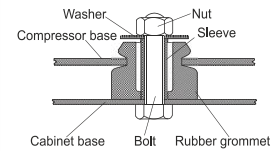

Snap-on

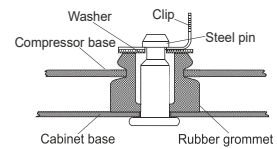

Mounting accessories

	one comp.	multi pack
Bolt joint M6 ø16mm	118-1917	118-1918
Bolt joint ø1/4" ø16mm	118-1946	
Bolt joint ø1/4" ø19mm	118-1949	
Snap-on ø7,3 ø16mm	118-1947	118-1919

Application notes

Compressor with oil cooler.

Model

Designation	FR7GH	220-240V/50Hz	Conf. 1	Sales code:	103G6692
-------------	--------------	----------------------	----------------	-------------	-----------------

Configuration

Motorconfiguration	CSIR
Power supply (nominal)	220-240V/50Hz 1~
Refrigerant	R134a
Application	MBP+HBP
Voltage range	198-254V
Starting torque	HST
Approvals	CCC

Electrical accessories / wiring diagram

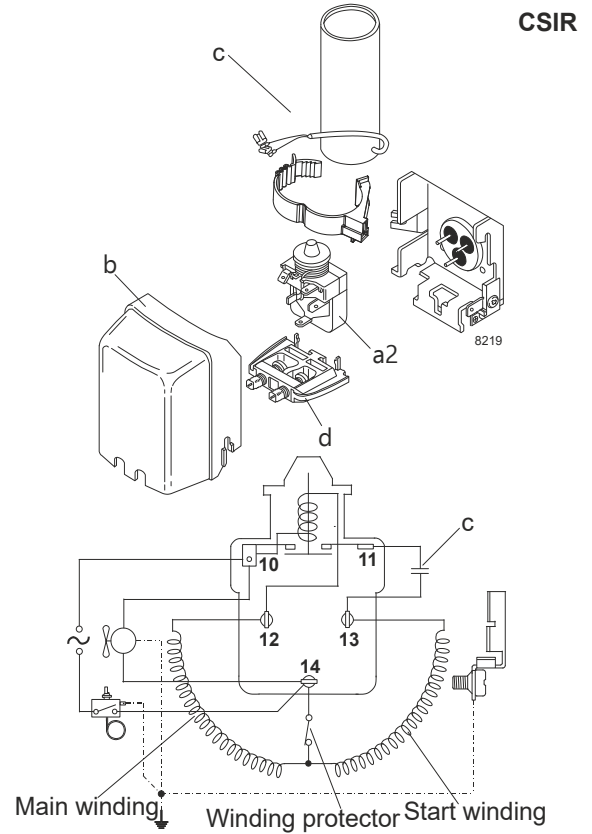

Ambient temperatures / system cooling

Ambient temperature min.:	10°C / 50°F
Ambient temperature max.:	43°C / 110°F

System cooling (n/a: outside limits)			
T ambient	LBP	MBP	HBP
32°C / 90°F	n/a	oil cooled	oil cooled
38°C / 100°F	n/a	oil cooled	oil cooled
43°C / 110°F	n/a	oil cooled	oil cooled

Operation pressure range

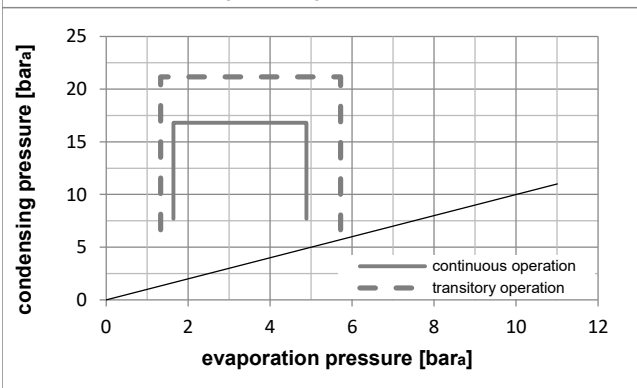
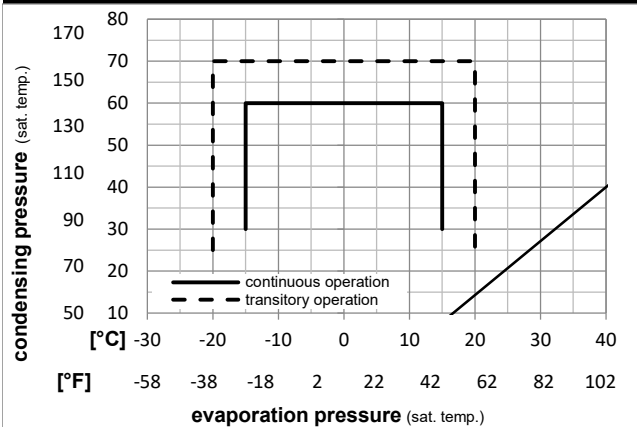

Components

a2	relay	117U6016
c	start capacitor (80µF)	117U5015
b	plastic cover	103N2011
d	cord relief	103N1010

Model

Designation **FR7GH 220-240V/50Hz** Conf. 1 Sales code: **103G6692**

Optimization + standard conditions

220V/50Hz, CSIR, fan 1,5m/s, CCC

Evaporating pressure (saturation temperature)					Condensing pressure (saturation temperature)						Power consumption				ASHRAE HBP	
Return gas temp.					Liquid temp.						Current consumption					Ref. mass flow m
Cooling capacity					COP		EER		P1	I	m					
pe	pc	RGT	Tliq	[W]	[Btu/h]	[kcal/h]	[W/W]	[Btu/Wh]	[kcal/Wh]	[W]	[A]	[kg/h]				
[°C]	7,22	54,4	35	46,1	645,2	2203	555,2	2,44	8,33	2,10	264,6	1,72	14,31			
[°F]	45	130	95	115												
[°C]	5	55	32	55	525,4	1794	452,1	2,04	6,95	1,75	258,2	1,70	12,95	cecomaf HBP		
[°F]	41	131	89,6	131												
[°C]	5	50	20	50	553,7	1891	476,5	2,23	7,60	1,92	248,7	1,67	13,95	EN12900 HBP		
[°F]	41	122	68	122												
[°C]	-6,66	54,4	35	46,1	334,8	1143	288,1	1,60	5,47	1,38	208,9	1,53	7,30	ASHRAE MBP		
[°F]	20	130	95	115												
[°C]	-10	55	32	55	255,2	872	219,7	1,33	4,53	1,14	192,4	1,47	6,17	cecomaf MBP		
[°F]	14	131	89,6	131												
[°C]	-10	45	20	45	301,9	1031	259,8	1,61	5,51	1,39	187,2	1,48	7,07	EN12900 MBP		
[°F]	14	113	68	113												

Performance tables

220V/50Hz, CSIR, fan 1,5m/s, CCC

	pe	Cooling capacity			COP		EER		P1	I	m
	[°C]	[°F]	[W]	[Btu/h]	[kcal/h]	[W/W]	[Btu/Wh]	[kcal/Wh]	[W]	[A]	[kg/h]
[°C / °F]	-15	5	242,0	826	208,2	1,47	5,02	1,27	164,5	1,42	5,27
cond. pressure	-10	14	313,2	1070	269,5	1,67	5,71	1,44	187,2	1,48	6,85
pc= 45/113	-5	23	400,9	1369	345,0	1,94	6,62	1,67	206,9	1,54	8,82
return gas temp.	0	32	506,7	1730	436,1	2,26	7,73	1,95	223,8	1,60	11,21
RGT= 32/90	5	41	632,3	2160	544,2	2,66	9,08	2,29	237,8	1,64	14,08
liquid temp	10	50	779,5	2662	670,8	3,13	10,69	2,69	249,0	1,68	17,49
Tliq= 45/113	15	59	949,8	3244	817,4	3,69	12,61	3,18	257,2	1,72	21,51
[°C / °F]	-15	5	199,0	680	171,2	1,21	4,13	1,04	164,7	1,38	4,79
cond. pressure	-10	14	255,2	872	219,7	1,33	4,53	1,14	192,4	1,47	6,17
pc= 55/131	-5	23	327,3	1118	281,7	1,51	5,15	1,30	217,2	1,55	7,96
return gas temp	0	32	416,8	1423	358,7	1,74	5,95	1,50	239,1	1,63	10,19
RGT= 32/90	5	41	525,4	1794	452,1	2,04	6,95	1,75	258,2	1,70	12,95
liquid temp	10	50	654,8	2236	563,5	2,39	8,15	2,05	274,3	1,76	16,28
Tliq= 55/131	15	59	806,7	2755	694,2	2,80	9,58	2,41	287,6	1,81	20,26

Model

Designation	FR7GH	220-240V/50Hz	Conf. 2	Sales code:	103G6692
-------------	--------------	----------------------	----------------	-------------	-----------------

Configuration

Motorconfiguration	CSIR
Power supply (nominal)	220-240V/50Hz 1~
Refrigerant	R513A
Application	MBP+HBP
Voltage range	198-254V
Starting torque	HST
Approvals	CCC

Electrical accessories / wiring diagram

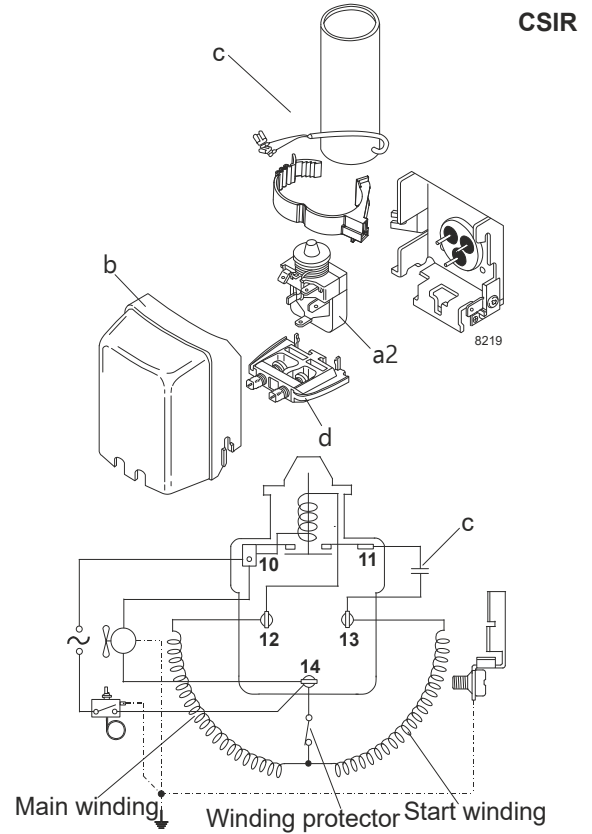

Ambient temperatures / system cooling

Ambient temperature min.:	10°C / 50°F
Ambient temperature max.:	43°C / 110°F

System cooling (n/a: outside limits)			
T ambient	LBP	MBP	HBP
32°C / 90°F	n/a	oil cooled	oil cooled
38°C / 100°F	n/a	oil cooled	oil cooled
43°C / 110°F	n/a	oil cooled	oil cooled

Operation pressure range

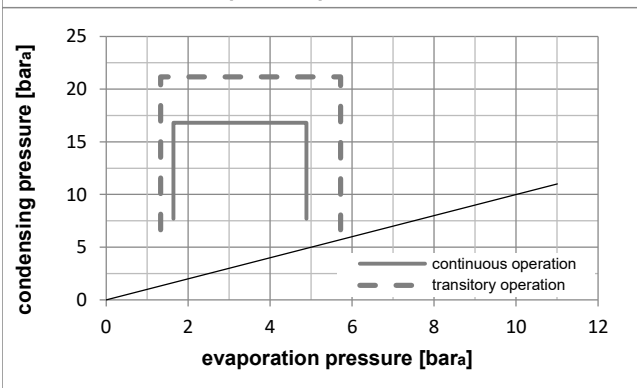
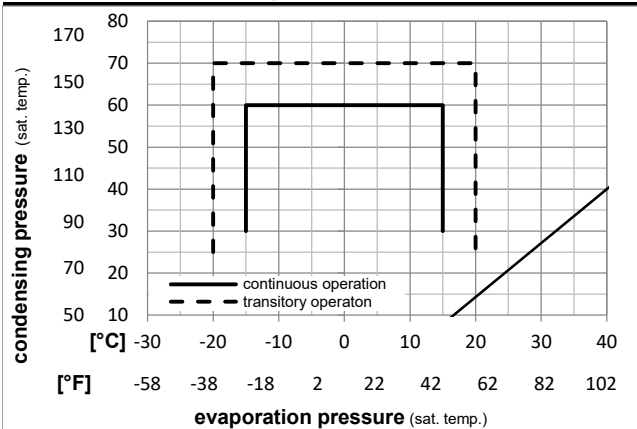

Components

a2	relay	117U6016
c	start capacitor (80µF)	117U5015
b	plastic cover	103N2011
d	cord relief	103N1010

Model

Designation	FR7GH	220-240V/50Hz	Conf. 2	Sales code:	103G6692
-------------	--------------	----------------------	----------------	-------------	-----------------

Optimization + standard conditions

220V/50Hz, CSIR, fan 1,5m/s, CCC

Evaporating pressure (saturation temperature)		Condensing pressure (saturation temperature)				Cooling capacity			COP	EER	Power consumption			ASHRAE HBP
Return gas temp.		Liquid temp.		[W]		[Btu/h]	[kcal/h]	[W/W]	[Btu/Wh]	[kcal/Wh]	P1	I	Ref. mass flow	
pe	pc	RGT	Tliq	[W]	[Btu/h]	[kcal/h]	[W/W]	[Btu/Wh]	[kcal/Wh]	[W]	[A]	[kg/h]		
[°C]	7,22	54,4	35	46,1	664,6	2270	572,0	2,41	8,24	2,08	275,5	1,77	16,51	ASHRAE HBP
[°F]	45	130	95	115										
[°C]	5	55	32	55	533,3	1821	459,0	1,98	6,76	1,70	269,4	1,75	14,99	cecomaf HBP
[°F]	41	131	89,6	131										
[°C]	5	50	20	50	563,0	1923	484,5	2,17	7,41	1,87	259,5	1,72	16,14	EN12900 HBP
[°F]	41	122	68	122										
[°C]	-6,66	54,4	35	46,1	353,1	1206	303,9	1,60	5,46	1,38	220,9	1,59	8,65	ASHRAE MBP
[°F]	20	130	95	115										
[°C]	-10	55	32	55	266,4	910	229,3	1,30	4,46	1,12	204,2	1,54	7,37	cecomaf MBP
[°F]	14	131	89,6	131										
[°C]	-10	45	20	45	316,9	1082	272,7	1,60	5,47	1,38	198,0	1,52	8,40	EN12900 MBP
[°F]	14	113	68	113										

Performance tables

220V/50Hz, CSIR, fan 1,5m/s, CCC

pe	Cooling capacity					COP	EER	P1		I	m
	[°C]	[°F]	[W]	[Btu/h]	[kcal/h]	[W/W]	[Btu/Wh]	[kcal/Wh]	[W]	[A]	[kg/h]
[°C / °F]	-15	5	258,8	884	222,8	1,48	5,06	1,27	174,9	1,45	6,34
cond. pressure	-10	14	331,4	1132	285,2	1,67	5,72	1,44	198,0	1,52	8,15
pc= 45/113	-5	23	420,1	1435	361,6	1,93	6,59	1,66	217,8	1,58	10,37
return gas temp.	0	32	526,7	1799	453,3	2,25	7,67	1,93	234,5	1,64	13,06
RGT= 32/90	5	41	652,7	2229	561,7	2,63	8,99	2,26	248,0	1,68	16,28
liquid temp	10	50	799,5	2730	688,0	3,09	10,56	2,66	258,5	1,71	20,07
Tliq= 45/113	15	59	968,7	3308	833,7	3,64	12,43	3,13	266,1	1,74	24,51
[°C / °F]	-15	5	210,3	718	181,0	1,20	4,08	1,03	176,0	1,45	5,79
cond. pressure	-10	14	266,4	910	229,3	1,30	4,46	1,12	204,2	1,54	7,37
pc= 55/131	-5	23	337,9	1154	290,8	1,47	5,04	1,27	229,2	1,62	9,39
return gas temp	0	32	426,4	1456	367,0	1,70	5,80	1,46	250,9	1,69	11,91
RGT= 32/90	5	41	533,3	1821	459,0	1,98	6,76	1,70	269,4	1,75	14,99
liquid temp	10	50	660,3	2255	568,3	2,32	7,91	1,99	284,9	1,80	18,69
Tliq= 55/131	15	59	808,9	2762	696,1	2,72	9,29	2,34	297,4	1,84	23,10

Model

Designation	FR7GH	208-230V/60Hz	Conf. 3	Sales code:	103G6692
-------------	--------------	----------------------	----------------	-------------	-----------------

Configuration

Motorconfiguration	CSIR
Power supply (nominal)	208-230V/60Hz 1~
Refrigerant	R134a
Application	MBP+HBP
Voltage range	198-254V
Starting torque	HST
Approvals	CCC

Electrical accessories / wiring diagram

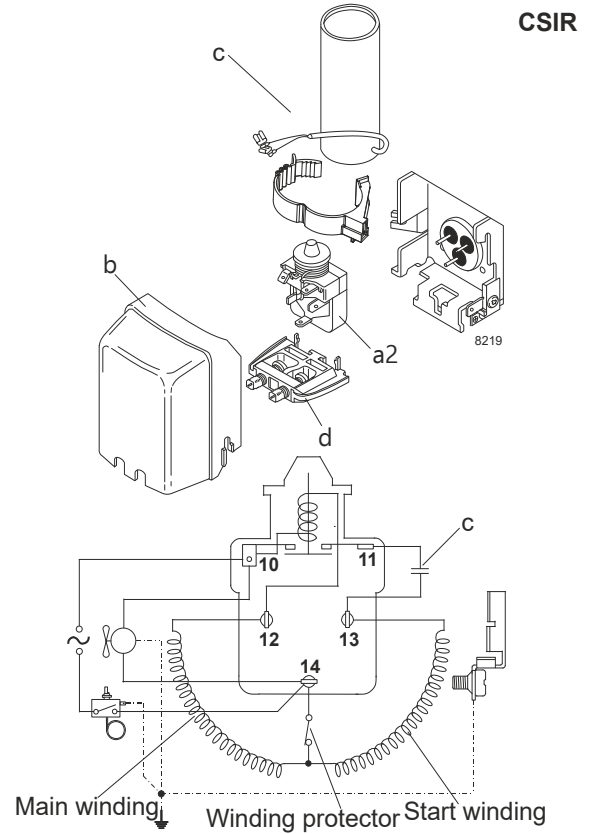

Ambient temperatures / system cooling

Ambient temperature min.:	10°C / 50°F
Ambient temperature max.:	43°C / 110°F

System cooling (n/a: outside limits)			
T ambient	LBP	MBP	HBP
32°C / 90°F	n/a	oil cooled	oil cooled
38°C / 100°F	n/a	oil cooled	oil cooled
43°C / 110°F	n/a	oil cooled	oil cooled

Operation pressure range

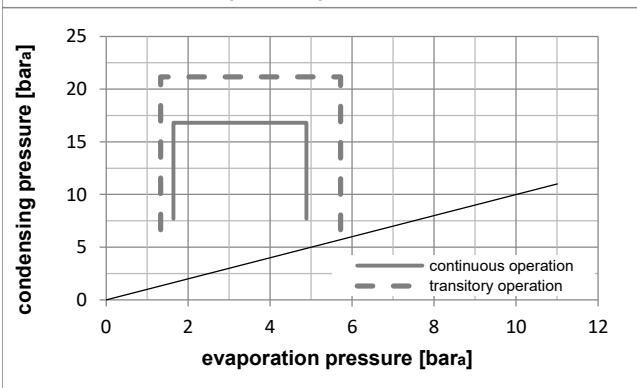
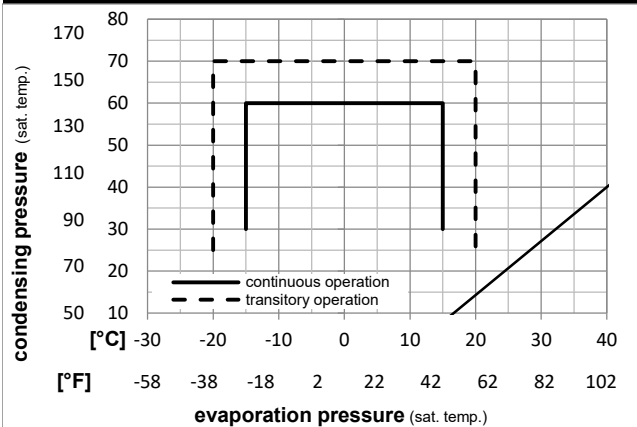

Components

a2	relay	117U6016
c	start capacitor (80µF)	117U5015
b	plastic cover	103N2011
d	cord relief	103N1010

Model

Designation **FR7GH 208-230V/60Hz** Conf. 3 Sales code: **103G6692**

Optimization + standard conditions

220V/60Hz, CSIR, fan 1,5m/s, CCC

Evaporating pressure (saturation temperature)					Condensing pressure (saturation temperature)					Power consumption								
					Return gas temp.					Current consumption								
					Liquid temp.													
					Cooling capacity					COP EER					P1	I	m	
pe	pc	RGT	Tliq		[W]	[Btu/h]	[kcal/h]	[W/W]	[Btu/Wh]	[kcal/Wh]	[W]	[A]	[kg/h]					
[°C]	7,22	54,4	35	46,1	742,7	2537	639,2	2,26	7,71	1,94	329,1	1,85	16,48				ASHRAE HBP	
[°F]	45	130	95	115														
[°C]	5	55	32	55	606,5	2071	522,0	1,91	6,54	1,65	316,9	1,79	14,95				cecomaf HBP	
[°F]	41	131	89,6	131														
[°C]	5	50	20	50	632,6	2160	544,4	2,12	7,23	1,82	299,0	1,74	15,94				EN12900 HBP	
[°F]	41	122	68	122														
[°C]	-6,66	54,4	35	46,1	386,6	1320	332,7	1,62	5,53	1,39	238,6	1,49	8,43				ASHRAE MBP	
[°F]	20	130	95	115														
[°C]	-10	55	32	55	293,9	1004	252,9	1,35	4,62	1,16	217,4	1,41	7,11				cecomaf MBP	
[°F]	14	131	89,6	131														
[°C]	-10	45	20	45	341,4	1166	293,8	1,62	5,52	1,39	211,2	1,41	7,99				EN12900 MBP	
[°F]	14	113	68	113														

Performance tables

220V/60Hz, CSIR, fan 1,5m/s, CCC

	pe	Cooling capacity				COP			EER			P1	I	m
	[°C]	[°F]	[W]	[Btu/h]	[kcal/h]	[W/W]	[Btu/Wh]	[kcal/Wh]	[W]	[A]	[kg/h]			
[°C / °F]	-15	5	271,1	926	233,3	1,46	4,99	1,26	185,7	1,34	5,91			
cond. pressure	-10	14	354,2	1210	304,8	1,68	5,73	1,44	211,2	1,41	7,75			
pc= 45/113	-5	23	454,9	1554	391,5	1,93	6,58	1,66	236,2	1,49	10,00			
return gas temp.	0	32	575,4	1965	495,2	2,21	7,54	1,90	260,6	1,58	12,72			
RGT= 32/90	5	41	717,6	2451	617,5	2,52	8,62	2,17	284,4	1,68	15,98			
liquid temp	10	50	883,5	3017	760,3	2,87	9,81	2,47	307,6	1,80	19,82			
Tliq= 45/113	15	59	1075,2	3672	925,3	3,26	11,12	2,80	330,1	1,92	24,35			
[°C / °F]	-15	5	225,3	770	193,9	1,22	4,18	1,05	184,1	1,31	5,42			
cond. pressure	-10	14	293,9	1004	252,9	1,35	4,62	1,16	217,4	1,41	7,11			
pc= 55/131	-5	23	378,9	1294	326,1	1,51	5,16	1,30	250,6	1,53	9,21			
return gas temp	0	32	482,4	1648	415,2	1,70	5,81	1,46	283,8	1,65	11,80			
RGT= 32/90	5	41	606,5	2071	522,0	1,91	6,54	1,65	316,9	1,79	14,95			
liquid temp	10	50	753,2	2572	648,2	2,15	7,35	1,85	349,9	1,94	18,72			
Tliq= 55/131	15	59	924,5	3157	795,6	2,42	8,25	2,08	382,7	2,10	23,22			

Model

Designation	FR7GH	208-230V/60Hz	Conf. 4	Sales code:	103G6692
-------------	--------------	----------------------	----------------	-------------	-----------------

Configuration

Motorconfiguration	CSIR
Power supply (nominal)	208-230V/60Hz 1~
Refrigerant	R513A
Application	MBP+HBP
Voltage range	198-254V
Starting torque	HST
Approvals	CCC

Electrical accessories / wiring diagram

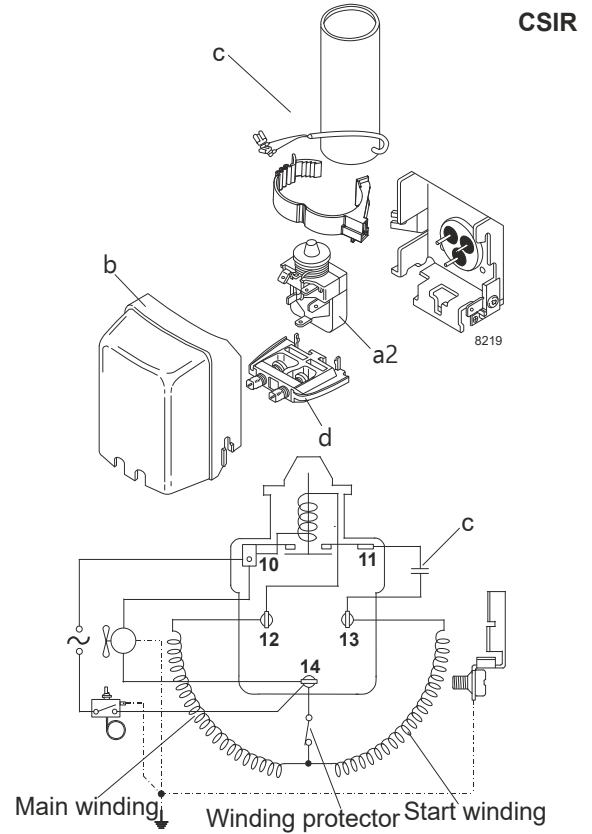

Ambient temperatures / system cooling

Ambient temperature min.:	10°C / 50°F
Ambient temperature max.:	43°C / 110°F

System cooling (n/a: outside limits)			
T ambient	LBP	MBP	HBP
32°C / 90°F	n/a	oil cooled	oil cooled
38°C / 100°F	n/a	oil cooled	oil cooled
43°C / 110°F	n/a	oil cooled	oil cooled

Operation pressure range

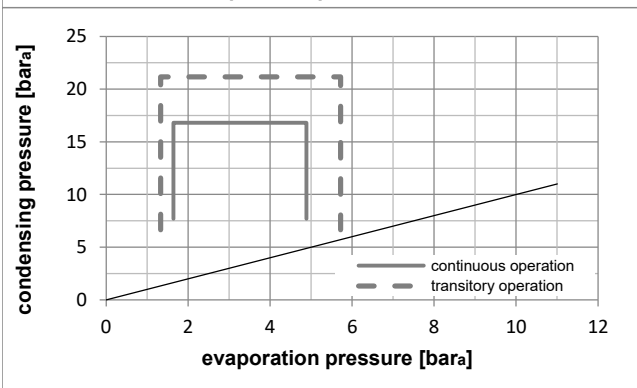
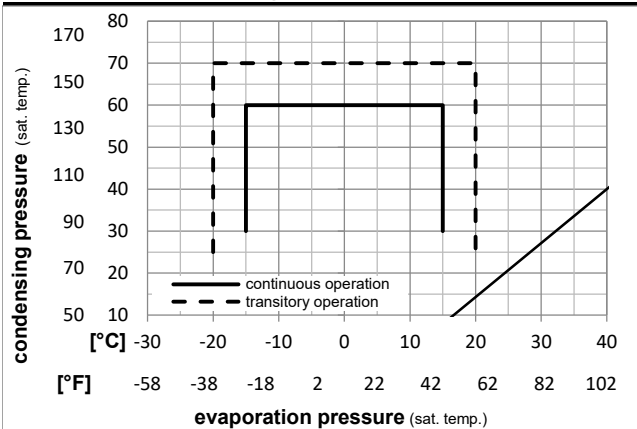

Components

a2	relay	117U6016
c	start capacitor (80µF)	117U5015
b	plastic cover	103N2011
d	cord relief	103N1010

Model

Designation **FR7GH 208-230V/60Hz** Conf. 4 Sales code: **103G6692**

Optimization + standard conditions

220V/60Hz, CSIR, fan 1,5m/s, CCC

Evaporating pressure (saturation temperature)					Condensing pressure (saturation temperature)					Power consumption					
					Return gas temp.					Current consumption					
					Liquid temp.										
					Cooling capacity					COP	EER	P1	I	Ref. mass flow	
pe	pc	RGT	Tliq		[W]	[Btu/h]	[kcal/h]	[W/W]	[Btu/Wh]	[kcal/Wh]	[W]	[A]	[kg/h]		
[°C]	7,22	54,4	35	46,1	765,0	2613	658,4	2,22	7,60	1,91	343,8	1,96	19,01	ASHRAE HBP	
[°F]	45	130	95	115											
[°C]	5	55	32	55	615,7	2103	529,9	1,86	6,34	1,60	331,8	1,92	17,30	cecomaf HBP	
[°F]	41	131	89,6	131											
[°C]	5	50	20	50	643,2	2197	553,6	2,06	7,02	1,77	312,9	1,84	18,44	EN12900 HBP	
[°F]	41	122	68	122											
[°C]	-6,66	54,4	35	46,1	407,7	1392	350,9	1,61	5,50	1,39	253,1	1,60	9,99	ASHRAE MBP	
[°F]	20	130	95	115											
[°C]	-10	55	32	55	306,7	1048	264,0	1,32	4,52	1,14	231,7	1,51	8,48	cecomaf MBP	
[°F]	14	131	89,6	131											
[°C]	-10	45	20	45	358,3	1224	308,4	1,60	5,46	1,37	224,3	1,49	9,50	EN12900 MBP	
[°F]	14	113	68	113											

Performance tables

220V/60Hz, CSIR, fan 1,5m/s, CCC

	pe	Cooling capacity			COP	EER	P1	I	m		
	[°C]	[°F]	[W]	[Btu/h]	[kcal/h]	[W/W]	[Btu/Wh]	[kcal/Wh]	[W]	[A]	[kg/h]
[°C / °F]	-15	5	289,9	990	249,5	1,46	4,99	1,26	198,4	1,38	7,10
cond. pressure	-10	14	374,7	1280	322,5	1,67	5,71	1,44	224,3	1,49	9,21
pc= 45/113	-5	23	476,8	1628	410,3	1,91	6,53	1,65	249,4	1,59	11,77
return gas temp.	0	32	598,2	2043	514,8	2,18	7,46	1,88	273,8	1,68	14,84
RGT= 32/90	5	41	740,6	2529	637,4	2,49	8,50	2,14	297,5	1,78	18,47
liquid temp	10	50	906,1	3094	779,8	2,83	9,66	2,43	320,4	1,87	22,75
Tliq= 45/113	15	59	1096,4	3744	943,6	3,20	10,93	2,75	342,5	1,96	27,74
[°C / °F]	-15	5	238,2	813	205,0	1,20	4,11	1,04	197,8	1,38	6,56
cond. pressure	-10	14	306,7	1048	264,0	1,32	4,52	1,14	231,7	1,51	8,48
pc= 55/131	-5	23	391,2	1336	336,7	1,47	5,04	1,27	265,3	1,65	10,87
return gas temp	0	32	493,6	1686	424,8	1,65	5,64	1,42	298,7	1,78	13,79
RGT= 32/90	5	41	615,7	2103	529,9	1,86	6,34	1,60	331,8	1,92	17,30
liquid temp	10	50	759,5	2594	653,6	2,08	7,11	1,79	364,7	2,05	21,50
Tliq= 55/131	15	59	926,7	3165	797,6	2,33	7,97	2,01	397,2	2,18	26,47