

# BD MICRO COMPRESSORS – MILESTONES IN MOBILE COOLING

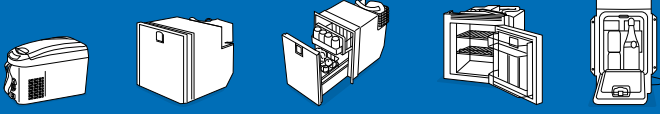

**BD Micro-Series**

 **Mobile Applications**





**Variable-Speed Efficiency**



**Premium Controller**



**Wide Application Range**



**Customization via Tool4Cool®**



**Small Footprint**

- **BD 1.4F-VSD.3 Features – Your Benefits**
  - Less than 2.3 kg – Portable applications are easier to carry
  - Reduced size, 60% less than standard – Increase your net volume
  - Covers LBP/MBP/HBP – One compressor for all applications
- **BD 1.4F-VSD.3 Functions – Reduced Energy Consumption**
  - Fan speed control, start/stop delays – Increased comfort, less noise
  - Compressor speed control – Less energy consumption and noise
  - ECO function – Energy savings, reduced noise
  - Mechanical or electronic thermostat – Easy installation, less costs
- **BD 1.4F-VSD.3 Functions – Reduced Service Costs**
  - Transport-stable – Long lifetime, less spare parts
  - Flexible programming options – Tool4Cool® or resistors
  - Communication interface – Easy development phase, open protocol
  - Protection against wrong polarity – Easy to install, no damage
  - Fan failure detection – Safety feature, easy trouble shooting
  - Start & stop delay for compressor and fans – Higher reliability
  - Battery protection – Avoid drainage, increase lifetime
  - PCB temperature protection – No overheating

The new **BD1.4F-VSD.3** (new generation with optimized noise level and released for refrigerant R1234yf) from Secop is 60% smaller than previous models and weighs in at only 2.3 kilos. The heavy duty (HD) version **BD1.4F-VSD-HD** can handle extreme vibrations.

Perfect for 10-30 liter in car/van/boat cabinets or portable boxes that need to fit into tight spaces without compromising storage space.

Specially designed for maximum efficiency and reliability, this powerhouse of a compressor makes it easier than ever to provide leading class mobile refrigerators. Enabling the variable speed function increases the system's COP/EER.

Low energy consumption is good for car/van/boat batteries – as well as the environment. The optimized, low-noise motor ensures outstanding performance when you want to provide that extra degree of luxury on the move. Cool beverages on demand make your journey so much more of an excellent experience.

The electronic thermostat (NTC sensor support) provides an accurate temperature while the failure detection allows a fast fault diagnosis. The computer interface makes it easier for customization.

Secop BD Micro compressors – milestones in mobile cooling.

General	BD1.4F-VSD.3	BD1.4F-VSD-HD
Refrigerant	R134a, R1234yf	R134a
Compressor (2.1 kg)	109Z0209	109Z0250
Electronic unit (0.11 kg)	101N2100	101N2100

Application		
Application	LBP/MBP/HBP	
Evaporating temperature	°C	-30 to 15
Voltage range	VDC	9.6-17 / 19-34
Speed range	rpm	2000-4000

Performance Data ASHRAE LBP		R1234yf				R134a			
Speed	rpm	2000	3000	3500	4000	2000	3000	3500	4000
Cooling capacity	W	15	27	31	38	14	24	29	34
Power consumption	W	18	28	33	40	17	26	31	36
COP	W/W	0.85	0.95	0.92	0.95	0.83	0.93	0.94	0.94

Test conditions @ -23.3°C evaporating temperature  
 Condensing temperature: 54.4°C | Suction gas temperature: 32.2°C  
 Ambient temperature: 32.2°C | Liquid temperature: 32.2°C

Performance Data ASHRAE MBP		R1234yf				R134a			
Speed	rpm	2000	3000	3500	4000	2000	3000	3500	4000
Cooling capacity	W	44	70	82	95	43	55	68	94
Power consumption	W	29	44	52	61	28	35	43	59
COP	W/W	1.52	1.59	1.57	1.57	1.53	1.57	1.60	1.60

Test conditions @ -23.3°C evaporating temperature  
 Condensing temperature: 54.4°C | Suction gas temperature: 35°C  
 Ambient temperature: 32.2°C | Liquid temperature: 46.1°C

Performance Data EN 12900/CECOMAF		R1234yf				R134a			
Speed	rpm	2000	3000	3500	4000	2000	3000	3500	4000
Cooling capacity	W	10	17	20	24	9	16	20	23
Power consumption	W	17	27	31	37	16	24	29	34
COP	W/W	0.58	0.66	0.64	0.66	0.59	0.67	0.68	0.68

Test conditions @ -25°C evaporating temperature  
 Condensing temperature: 55°C | Suction gas temperature: 32°C  
 Ambient temperature: 32°C | Liquid temperature: no subcooling

Dimensions			
Height	mm	A	96.25
		B / B1 / B2	91.25 / 88.00 / 25.20
Suction connector	location/I.D. mm   angle material   seal	C	6.2   25° Cu-plated steel   Al cap
			Process connector
Discharge connector	location/I.D. mm   angle material   seal	E	
			Connector tolerance

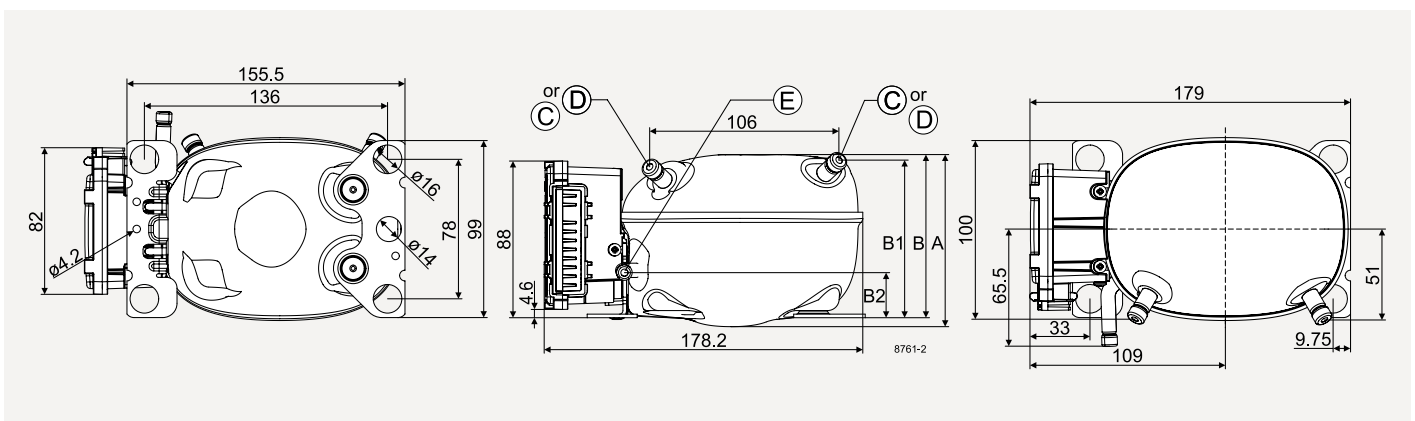

Secop GmbH · Lise-Meitner-Str. 29 · 24941 Flensburg, Germany · Tel: +49 461 4941 0 · [www.secop.com](http://www.secop.com)

Secop accepts no responsibility for possible errors in catalogs, brochures, and other printed material. Secop reserves the right to alter its products without notice. This also applies to products already on order provided that such alterations can be made without consequential changes being necessary to specifications already agreed. All trademarks in this material are the property of the respective companies. Secop and the Secop logotype are trademarks of Secop GmbH. All rights reserved.