

Secop is the first choice for partners looking for leading-edge refrigeration solutions and a premium customer experience.

Secop delivers advanced refrigeration compressors and controls, providing customers tailored sustainable solutions for light commercial, battery-driven, and special cooling applications.

ENERGY-OPTIMIZED PROPANE CONDENSING UNITS

SECCP

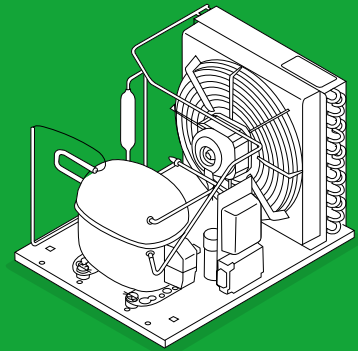
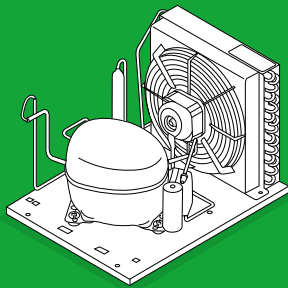

R290 · 220-240V · 50 Hz

KLF Compressors
NLE Compressors
SCE Compressors

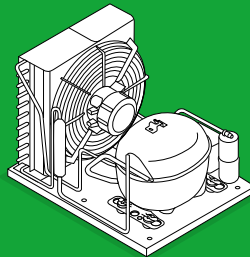

3 GWP

Achievable with powerful, efficient, and compact LBP/MBP condensing units complying with latest EU standards



Stationary
Cooling



KLF – Hermetic
Terminal Plug



Energy
Optimized



Wide Application
Range



EU Sustainable
Design



SECOP PROPANE CONDENSING UNITS

Your Benefits

Secop condensing units, just as Secop hermetic compressors, are built to provide outstanding efficiency and reliability, they offer valuable savings – no matter the application or operating conditions.

The range of condensing units from Secop all draw upon more than 20 years of experience and award-winning technology.

As always, the ambition is to deliver the highest possible efficiency while meeting the latest global energy regulations, including the Ecodesign directives that powerfully contribute to improvements the environmental performance of products.

Secop energy-optimized propane (R290) condensing units save additional cost by utilizing smaller compressor platforms. With these compressors, Secop perfectly meets the increasing market demand for high efficiency and natural refrigerants with a very low GWP.

The KL-Series condensing units include an innovative patented hermetic terminal plug. Backed by years of experience with hydrocarbons refrigerants, testing of R290 solutions, and optimization of system conversion from HFC to HC refrigerants, Secop has developed a new design for terminal plugs to prevent root causes for electrical arcs injection with flammable refrigerants. This has set a benchmark in the industry to support the design of reliable systems with new flammable refrigerants.

Environment

- VDE approved compressors for low GWP refrigerants
- Easy conversion with new drop-in replacement refrigerants

Ecodesign

- Complying with latest EU standards 2009/125/EC and 2015/1095 as well as EN 13215:2016 +A1:2020
- Electronically commutated (EC) energy saving fan motors

Suitability for severe working conditions

- Components selected to operate in the most challenging environments

Wide operational range

- Compressors designed to operate in a wide range of evaporating temperatures

Compact design

- Accurate compact design to match easy installation in limited space

Approvals

- Ecodesign (EU) 2015/1108, CE, UKCA, and VDE

PLEASE NOTE

You can find data sheets for each individual condensing unit with specific dimensional drawings and 3D CAD files for each condensing unit on our website at:

www.secop.com



Natural Refrigerant

HC models are using our energy-optimized NLE, SCE, and KLF propane (R290) compressors with a very low GWP and maximum performance.



Capillary Connection



- Condenser/fan
- Connector tubes with rubber plugs
- Process connector tube with Schrader valve
- Filter drier (R290 models)



EU Sustainable Design

Secop's full range of condensing units is designed and optimized to meet the European Ecodesign Directive.

PROPANE PORTFOLIO

Series	Displacement (cm ³)	Cooling Capacity	
		LBP (W) EN 13215*	MBP (W) EN 13215*
KL 	4.8–7.7	228–422	412–700
N 	8.8–12.6	404–582	737–996
S 	15.3–21.0	626–916	1204–1683

0–35
0–2000
0–3500

*Tsubcooling=2K, Tsuc=20 °C, Tamb=25 °C, LBP: pe=-25 °C, MBP: pe=-10 °C

APPLICATION MAP

Bottle Coolers Beverage Merchandizers	Ice Cream Freezers	Dispensers	Food Service Professional	Food Retail	Medical Applications	AC Special Applications	Customized Cooling Solutions
---	-----------------------	------------	------------------------------	----------------	-------------------------	----------------------------	------------------------------------

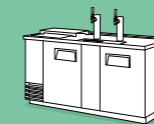

Keg Coolers

KL N S

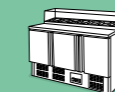

Preparation Tables

KL N S

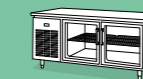

Undercounter Refrigerators

KL N



Show Cases
Bakery, Butchery ...

KL N S

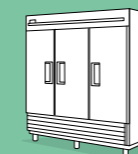

Solid Door
Stainless Steel

N S



Soft Scoop
Ice Cream Displays

N S



Reach-in
Refrigerators/Freezers

N S

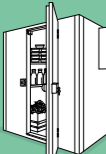

Walk-in Freezers

S

HC Condensing Units · LBP · 220-240 V · 50 Hz

Condensing unit						Compressor			EN 13215 Capacity [W] Tsubcooling = 2 K Tsuc = 20 °C, Tamb = 25 °C Evaporating temperature [°C]					EN 13215 Capacity [W] Tsubcooling = 2 K Tsuc = 20 °C, Tamb = 32 °C Evaporating temperature [°C]					EN 13215 Capacity [W] Tsubcooling = 2 K Tsuc = 20 °C, Tamb = 38 °C Evaporating temperature [°C]					EN 13215 Capacity [W] Tsubcooling = 2 K Tsuc = 20 °C, Tamb = 43 °C Evaporating temperature [°C]					Rated performance Tsubcooling = 2 K Tsuc = 20 °C, Tamb = 25 °C pe = -25 °C			Condenser size		Airflow [m³/h]	Dimensions							
Type designation	Code number	Connection	Refrigerant	Application	Voltage and frequencies	Type designation	Displacement [cm³]	Motor type	-40 -35 -25 -20 -10					-40 -35 -25 -20 -10					-40 -35 -25 -20 -10					-40 -35 -25 -20 -10					Power consumption [W]	Current consumption [A]	COP	Rows	Tubes		H [mm]	A [mm]	B [mm]	Weight [kg]	Receiver volume [l]	Valve		
									Evaporating temperature [°C]					Evaporating temperature [°C]					Evaporating temperature [°C]					Evaporating temperature [°C]																Suction (I.D.) Solder [mm]	Liquid (O.D.) Solder [mm]	
CUNLE126CNLCE	314H5002	Capillary	R290	LBP	220-240V, 50 Hz	NLE12.6CNL	12.6	CSIR	312	393	582	693	950	278	353	527	629	865	253	323	484	578	796	233	299	449	536	739	345	2.1	1.69	4	10	435	272	380	304	17.6	-	8	6	
CUSCE15CNLXCE	314H4000			LBP	220-240V, 50 Hz	SCE15CNLX	15.3	CSIR	311	395	626	767	1079	269	350	566	695	976	232	310	512	630	883	201	276	465	574	803	410	2.6	1.53	4	10	435	272	380	304	20.0	-	10	6	
CUSCE18CNLXCE	314H4001			LBP	220-240V, 50 Hz	SCE18CNLX	17.7	CSIR	396	483	740	901	1267	345	430	671	820	1148	303	385	611	746	1038	267	346	556	679	940	487	3.0	1.52	3	11	675	297	450	350	20.6	-	10	6	
CUSCE21CNLXCE	314H4002			LBP	220-240V, 50 Hz	SCE21CNLX	21.0	CSIR	444	589	916	1098	1493	401	527	818	981	1344	350	462	728	881	-	313	415	663	808	-	578	3.3	1.58	5	11	581	297	450	350	21.4	-	10	6	
CUKLF48CND0CE	314H6001			LBP/MBP	220-240V, 50 Hz	KLF4.8CND	4.8	CSIR	100	137	228	283	412	95	130	213	263	378	83	117	195	241	347	72	104	178	221	320	161	1.1	1.42	2	10	510	272	380	307	14.2	-	8	6	
CUKLF56CND0CE	314H6002			LBP/MBP	220-240V, 50 Hz	KLF5.6CND	5.6	CSIR	98	140	250	317	477	115	152	247	305	444	115	149	235	288	413	106	139	219	268	383	169	1.2	1.48	2	10	510	272	380	307	14.5	-	8	6	
CUKLF66CND0CE	314H6003			LBP/MBP	220-240V, 50 Hz	KLF6.6CND	6.6	CSIR	186	219	319	385	543	161	196	292	354	499	138	174	269	327	460	118	155	247	302	426	218	1.6	1.46	2	10	510	272	380	307	14.5	-	8	6	
CUKLF77CND0CE	314H6004			LBP/MBP	220-240V, 50 Hz	KLF7.7CND	7.7	CSIR	258	299	422	503	700	216	259	380	458	645	184	227	346	421	597	161	204	319	390	556	237	1.6	1.78	3	11	551	297	450	350	15.2	-	8	6	
CUNLE88CN0CE	314H5000			LBP/MBP	220-240V, 50 Hz	NLE8.8CN	8.8	CSIR	-	253	404	501	737	-	263	397	482	688	-	247	372	449	634	-	223	343	415	586	245	1.7	1.65	3	11	551	297	450	350	17.1	-	8	6	
CUNLE10CN00CE	314H5001			LBP/MBP	220-240V, 50 Hz	NLE10CN	10.1	CSIR	-	292	469	580	843	-	292	448	546	777	-	269	411	500	710	-	241	375	459	654	310	2.1	1.51	3	11	551	297	450	350	18.2	-	8	6	

HC Condensing Units · MBP · 220-240 V · 50 Hz

Condensing unit						Compressor			EN 13215 Capacity [W] Tsubcooling = 2 K Tsuc = 20 °C, Tamb = 25 °C Evaporating temperature [°C]					EN 13215 Capacity [W] Tsubcooling = 2 K Tsuc = 20 °C, Tamb = 32 °C Evaporating temperature [°C]					EN 13215 Capacity [W] Tsubcooling = 2 K Tsuc = 20 °C, Tamb = 38 °C Evaporating temperature [°C]					EN 13215 Capacity [W] Tsubcooling = 2 K Tsuc = 20 °C, Tamb = 43 °C Evaporating temperature [°C]					Rated performance Tsubcooling = 2 K Tsuc = 20 °C, Tamb = 25 °C pe = -10 °C			Condenser size		Airflow [m³/h]	Dimensions							
Type designation	Code number	Connection	Refrigerant	Application	Voltage and frequencies	Type designation	Displacement [cm³]	Motor type	-20 -15 -10 0 5					-20 -15 -10 0 5					-20 -15 -10 0 5					-20 -15 -10 0 5					Power consumption [W]	Current consumption [A]	COP	Rows	Tubes		H [mm]	A [mm]	B [mm]	Weight [kg]	Receiver volume [l]	Valve		
									Evaporating temperature [°C]					Evaporating temperature [°C]					Evaporating temperature [°C]					Evaporating temperature [°C]																Suction (I.D.) Solder [mm]	Liquid (O.D.) Solder [mm]	
CUKLF48CND0CE	314H6001	Capillary	R290	LBP/MBP	220-240V, 50 Hz	KLF4.8CND	4.8	CSIR	283	344	412	565	649	263	318	378	516	592	241	291	347	473	542	221	268	320	436	501	193	1.2	2.13	2	10	510	272	380	307	14.2	-	8	6	
CUKLF56CND0CE	314H6002			LBP/MBP	220-240V, 50 Hz	KLF5.6CND	5.6	CSIR	316	389	467	640	733	301	364	433	586	669	281	337	399	538	614	260	312	369	498	568	225	1.4	2.08	2	10	510	272	380	307	14.5	-	8	6	
CUKLF66CND0CE	314H6003			LBP/MBP	220-240V, 50 Hz	KLF6.6CND	6.6	CSIR	385	460	543	727	825	354	423	499	665	752	327	391	460	610	688	302	362	426	563	633	279	1.8	1.95	2	10	510	272	380	307	14.5	-	8	6	
CUKLF77CND0CE	314H6004			LBP/MBP	220-240V, 50 Hz	KLF7.7CND	7.7	CSIR	503	596	700	938	1068	458	547	645	866	986	421	505	597	801	912	390	470	556	746	847	314	1.9	2.23	3	11	551	297	450	350	15.2	-	8	6	
CUNLE88CN0CE	314H5000			LBP/MBP	220-240V, 50 Hz	NLE8.8CN	8.8	CSIR	501	613	737	1023	1182	482	579	688	938	1078	449	536	634	859	985	415	496	586	793	908	315	1.9	2.34	3	11	551	297	450	350	17.1	-	8	6	
CUNLE10CN00CE	314H5001			LBP/MBP	220-240V, 50 Hz	NLE10CN	10.1	CSIR	580	706	843	1147	1309	546	656	777	1045	1189	500	600	710	953	1085	459	552	654	881	1004	397	2.4	2.12	3	11	551	297	450	350	18.2	-	8	6	
CUNLE126MNCE	314H5003			MBP	220-240V, 50 Hz	NLE12.6MN	12.6	CSIR	712	848	996	1323	1496	650	771	905	1199	1355	593	705	827	1097	1239	547	651	766	1017	-	469	2.8	2.12	3	11	675	297	450	350	18.7	-	8	6	
CUSCE15MNX0CE	314H4003			MBP	220-240V, 50 Hz	SCE15MNX	15.3	CSIR	831	1009	1204	1629	1853	758	922	1100	1486	1687	694	846	1009	1360	1541	639	780	931	1253	1418	538	3.1	2.24	5	11	581	297	450	350	21.5	-	10	6	
CUSCE18MNX0CE	314H4004			MBP	220-240V, 50 Hz	SCE18MNX	17.7	CSIR	1013	1224	1461	1994	2283	922	1117	1334	1821	2083	848	1029	1230	1679	1920	785	956	1145	1563	1786	646	4.1	2.26	4	13	986	345	490	390	23.5	-	10	6	
CUSCE21MNX0CE	314H4005			MBP	220-240V, 50 Hz	SCE21MNX	21.0	CSR	1205	1433	1683	2255	2573	1110	1319	1545	2053	2335	1023	1215	1420	1875	2125	941	1120	1308	1718	1942	723	3.6	2.33	4	13	986	345	490	390	26.8	-	10	6	

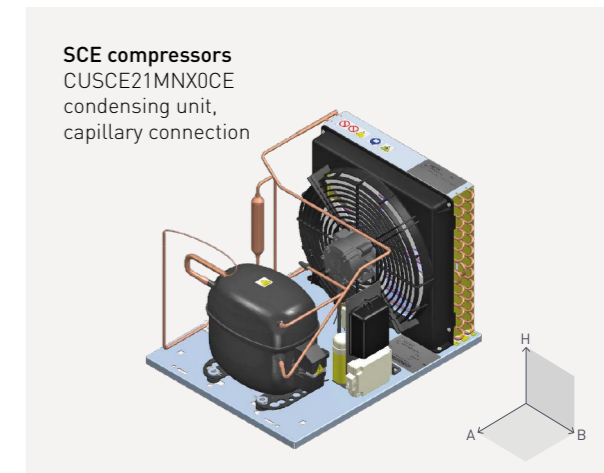
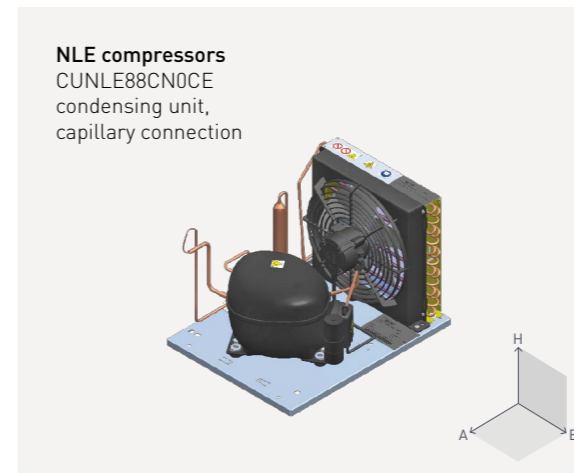
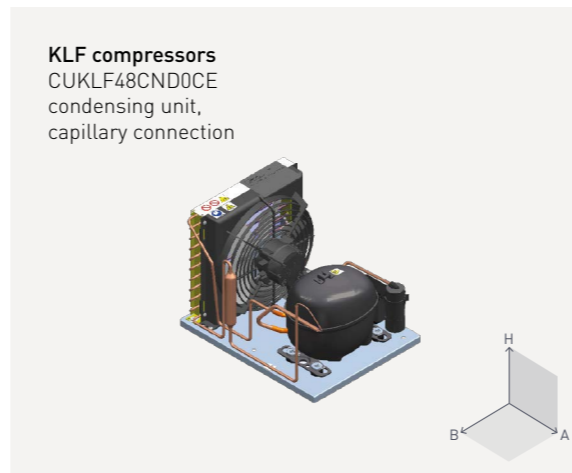
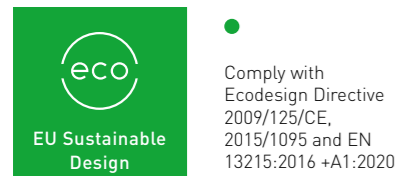

KLF condensing unit, capillary connection

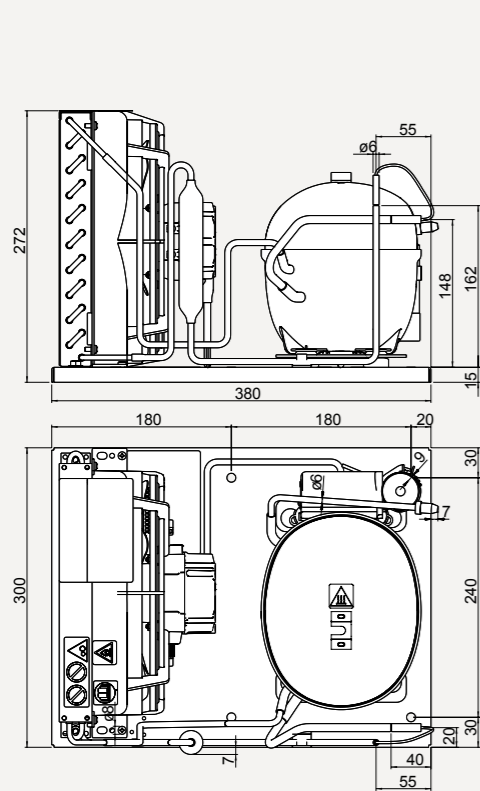

NLE condensing unit, capillary connection

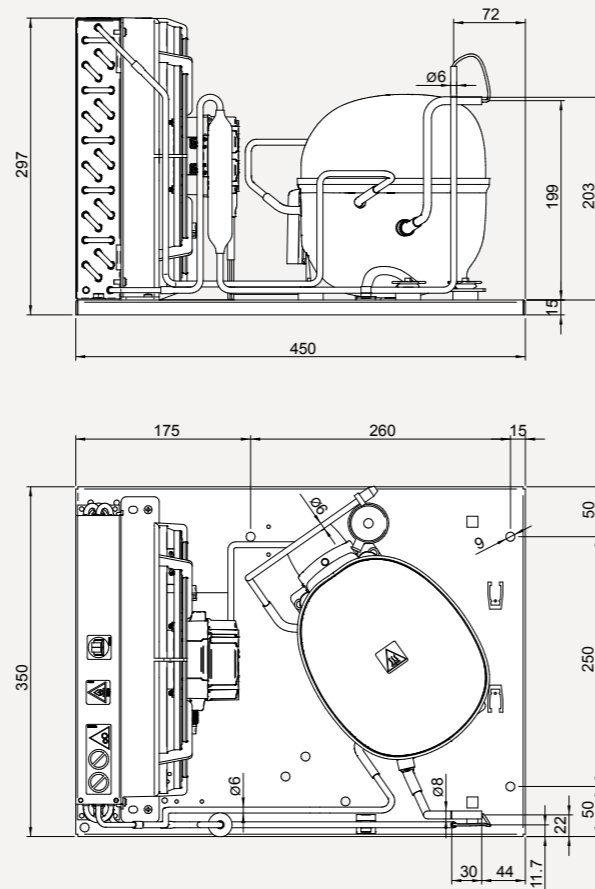

SCE condensing unit, capillary connection

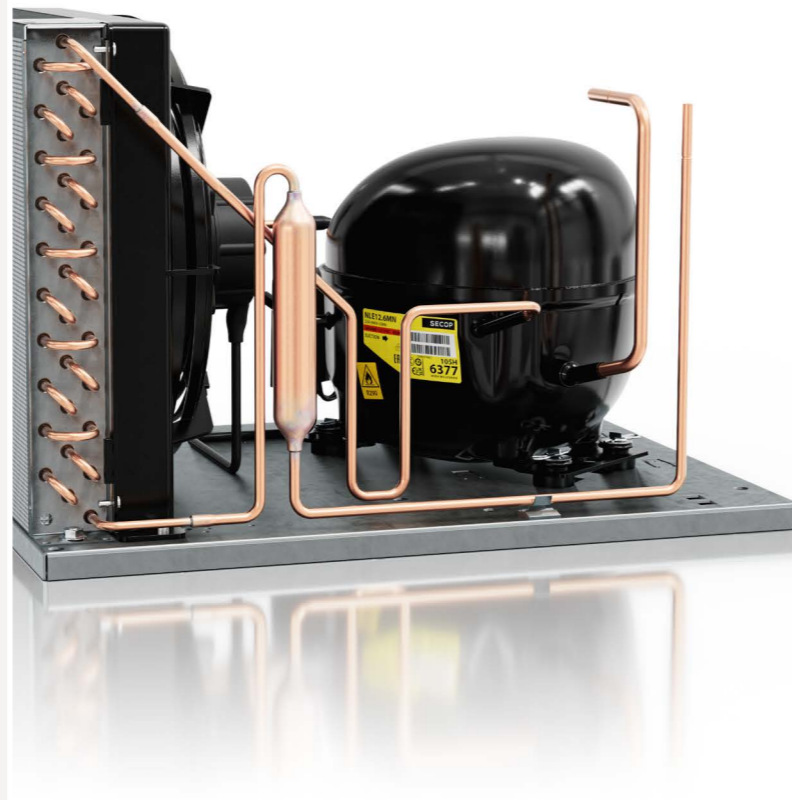
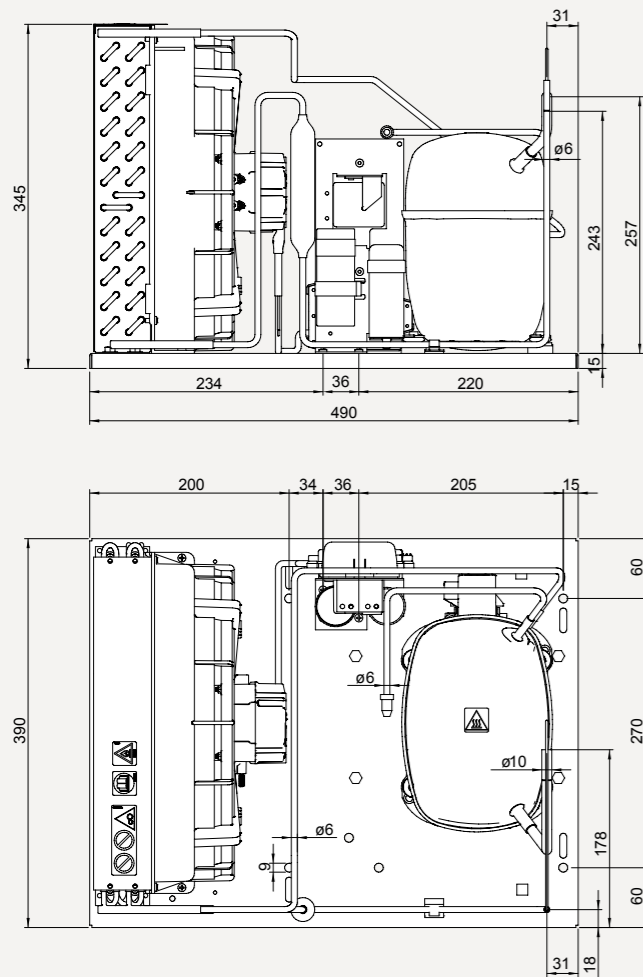

Electrical Equipment - Motor Systems

HST - CSIR

KLF - external protector

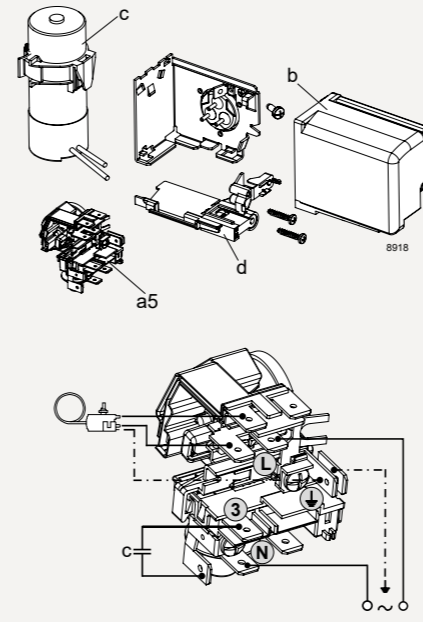

NLE

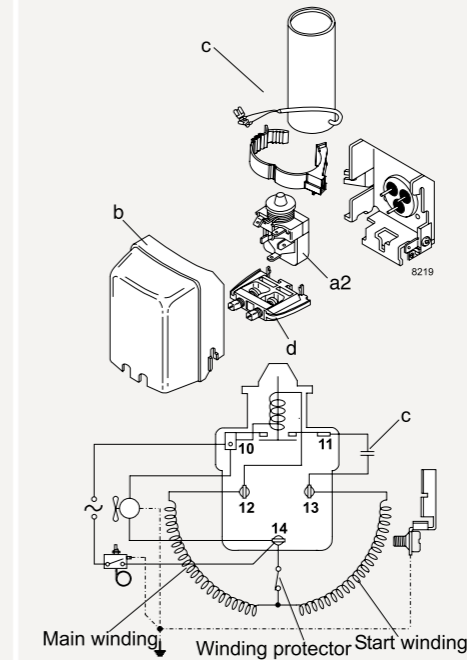

SCE - external protector

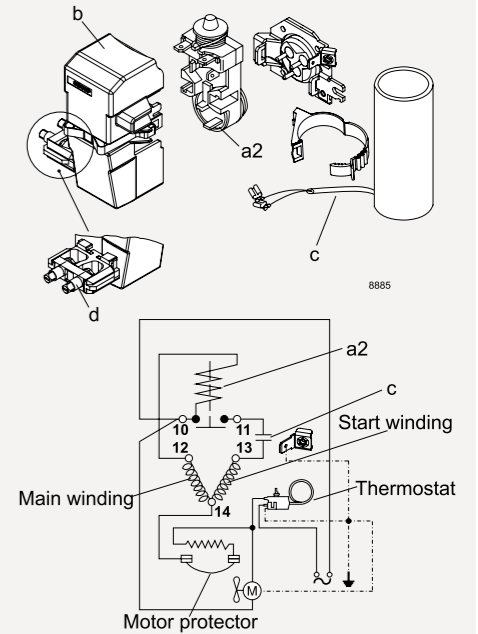

HST - CSCR

SCE - external protector

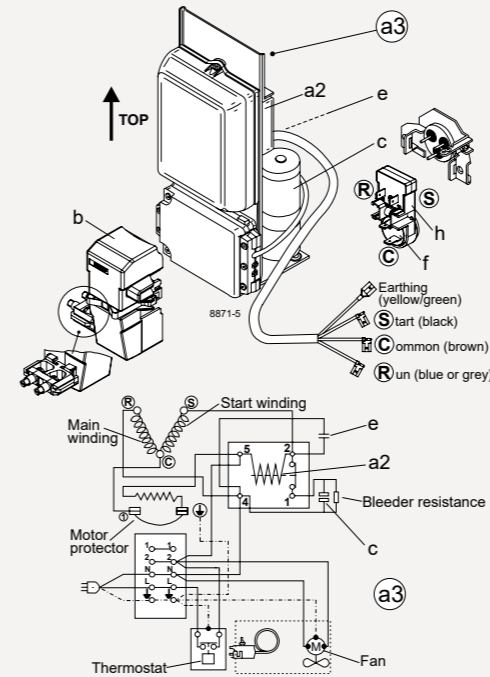

SCE - external protector

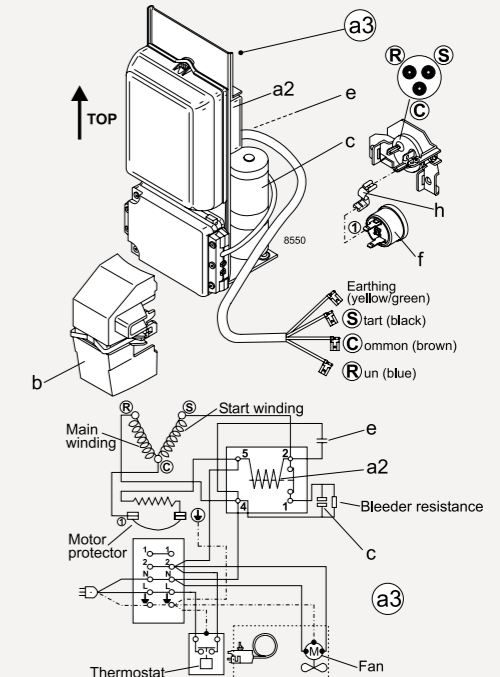

Motor types

- RSIR:** Resistant Start Induction Run
- RSCR:** Resistant Start Capacitor Run
- CSIR:** Capacitor Start Induction Run
- CSCR:** Capacitor Start Capacitor Run

Starting devices

- LST:** Low Starting Torque
LST is used with capillary tube control and pressure equalizing. (Pressure equalizing may exceed 10 minutes). The PTC starting device requires 5 minutes cooling before each start.
- HST:** High Starting Torque
HST consisting of relay and starting capacitor is used for expansion valve control or for capillary tube control without pressure equalizing.

Legend

- a1:** PTC starting device
- a2:** Starting relay
- a3:** Starting device
- a5:** Starting relay
- b:** Cover
- b1:** Clamp (part of compressor)
- b2:** Gasket (part of compressor)
- c:** Starting capacitor
- d:** Cord relief
- e:** Run capacitor
- f:** Protector
- g:** Protection screen for PTC
- h:** Holder

SECOP GROUP: AROUND THE WORLD



12
international
partner for
advanced
developments

33
laboratories
located in Austria,
Germany, Slovakia,
China, US, and
Turkey

160
R&D engineers
and technicians







440
patents globally

50+
countries with
customer support



Secop is the expert for advanced hermetic compressor technologies and cooling solutions in commercial refrigeration. We develop high performance stationary and mobile cooling solutions for leading international commercial refrigeration manufacturers and are the first choice when it comes to leading hermetic compressors and electronic controls for refrigeration solutions for light commercial and DC-powered applications.

Secop was formerly known as Danfoss Compressors and is one of the founding fathers of modern compressor technology with years of experience that goes back to the beginning of the 1950s.

-  **Flensburg:** Sales and R&D
-  **Zlaté Moravce:** R&D, Logistics and Manufacturing
-  **Turin:** Sales
-  **Tianjin:** Sales, R&D, Logistics and Manufacturing
-  **Gleisdorf:** R&D
-  **Atlanta:** Sales and Logistics



Secop GmbH · Lise-Meitner-Str. 29 · 24941 Flensburg, Germany · Tel: +49 461 4941 0 · www.secop.com

Secop accepts no responsibility for possible errors in catalogs, brochures, and other printed material. Secop reserves the right to alter its products without notice. This also applies to products already on order provided that such alterations can be made without subsequential changes being necessary to specifications already agreed. All trademarks in this material are the property of the respective companies. Secop and the Secop logotype are trademarks of Secop GmbH. All rights reserved.