

# Singolo Imballi



## Single Pack NF7.3FX.2 115-127V 60Hz CSIR

Codice Imballo Singolo: **195B4010**

Posizione	Titolo	Codice	Quantità
1	Compressor NF7.3FX.2	105G5719	1
2	Bolt joint for one compressor   M6   ø16mm	118-1917	1

**Secop GmbH** • Lise-Meitner-Straße 29 • 24941 Flensburg, Germany • Tel: +49 46149410 • [www.secop.com](http://www.secop.com)

Secop non si assume alcuna responsabilità per eventuali errori presenti in cataloghi, brochure e altro materiale stampato. Secop si riserva il diritto di modificare i propri prodotti senza preavviso. Ciò vale anche per i prodotti già ordinati, a condizione che tali modifiche possano essere apportate senza che siano necessarie modifiche successive alle specifiche già concordate. Tutti i marchi presenti in questo materiale sono di proprietà delle rispettive aziende. Secop e il logo Secop sono marchi di Secop GmbH. Tutti i diritti sono riservati.

## Model

Designation	<b>NF7.3FX.2</b>	115-127V/60Hz 1~	Sales code:	<b>105G5719</b>
-------------	------------------	------------------	-------------	-----------------

## Compressor design

Oil type	Polyolester	Refrigerant(s)	<b>R134a, R513A, 0</b>
Oil viscosity	32cST	Displacement	7,27cm <sup>3</sup> / 0,44cu.in
Oil quantity	268cm <sup>3</sup> / 9,1fl.oz	Compressors on pallet	80
Refr. charge - tech. limit	400g / 14,1oz		
Free gas volume comp.	2360cm <sup>3</sup> / 79,8fl.oz		
Weight	10kg / 22lbs		
Motor protection	external		
Winding resistance main	1,6Ω (at 25°C)		
Winding resistance aux	6,2Ω (at 25°C)		
Max. winding temp.	125°C / 257°F		
Max. discharge temp.	130°C / 266°F		



## General - Configurations with NF7.3FX.2

	<b>Conf. 1</b>	<b>Conf. 2</b>
Motorconfiguration	CSIR	CSIR
Power supply (nominal)	115-127V/60Hz	115-127V/60Hz
Number of phases	1	1
Voltage range	95-135V	95-135V
Approvals	UL	UL
Starting torque	HST	HST
Note	Electrical equipment is included and pre-assembled to compressor.	

## Applications with NF7.3FX.2

	<b>Conf. 1</b>	<b>Conf. 2</b>
Refrigerant	R134a	R513A
Application	LBP+MBP	LBP+MBP
System cooling	fan 1,5m/s	fan 1,5m/s
Hot gas defrost	-/-	-/-
Long interval pull down	OK	OK

## Electrical data - Configurations with NF7.3FX.2

	<b>Conf. 1</b>	<b>Conf. 2</b>
Starting device type	relay	relay
Run capacitor	-/-	-/-
Start capacitor	280μF	280μF
LRA (locked rotor amps / 4s/ U(N))		
RLA (rated load amps / 1s/ U(N))		
Cut in current (U(N))		

## Model

Designation

**NF7.3FX.2**

115-127V/60Hz 1~

Sales code:

**105G5719**

## Compressor dimensions

Housing	A Height	197mm / 7,76in
	B Height	191mm / 7,52in
	C Length shell	205mm / 8,07in
	D Length w. cover	254mm / 10in
	E Width	166mm / 6,54in

Connectors		Suction	Discharge	Process
		X	Y	Z
Diameter	[mm]	øi 8,11-8,29	øi 6,41-6,59	øi 6,41-6,59
	(i:inside, o:outside) [in]	øi 0,32-0,33	øi 0,25-0,26	øi 0,25-0,26
Material		copper	copper	copper
Horizontal angle	±2°	0°	0°	0°
Vertical angle	±2°	15°	35°	155°
Position l/h/w	[mm]	126/76/78	133/103/54	-107/94/72
	[in]	4,9/3/3,1	5,2/4/2,1	-4,2/3,7/2,8
Straight tube l.	[mm]	12	12	12
	[in]	0,5	0,5	0,5

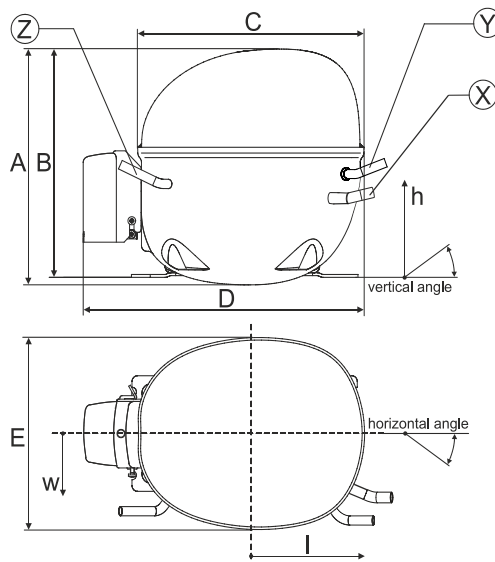

## Compressor fixation



### Bolt joint



### Snap-on

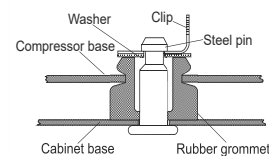

## Mounting accessories

	one comp.	multi pack
Bolt joint   M6   ø16mm	118-1917	118-1918
Bolt joint   ø1/4"   ø16mm	118-1946	
Bolt joint   ø1/4"   ø19mm	118-1949	
Snap-on   ø7,3   ø16mm	118-1947	118-1919

## Application notes

Provision for PE Grounding is located at the PE Stamp on the compressor

### Model

Designation	<b>NF7.3FX.2</b>	<b>115-127V/60Hz</b>	Conf. 1	Sales code:	<b>105G5719</b>
-------------	------------------	----------------------	---------	-------------	-----------------

### Configuration

Motorconfiguration	CSIR
Power supply (nominal)	115-127V/60Hz 1~
Refrigerant	R134a
Application	LBP+MBP
Voltage range	95-135V
Starting torque	HST
Approvals	UL

### Electrical accessories / wiring diagram

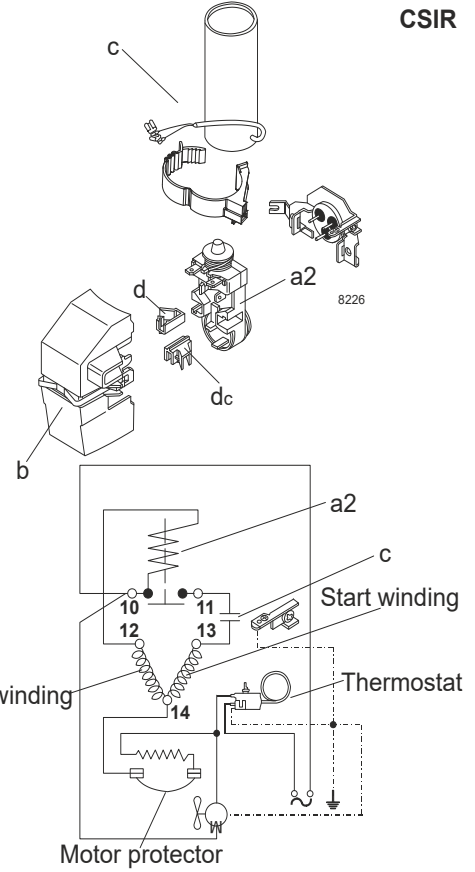

### Ambient/ machine room temperatures minimum /maximum

Ambient temperature range: 10 - 43°C / 50 - 110°F

Machine room temperature range: 10 - 48°C / 50 - 119°F

Compressor cooling: fan 1,5m/s

### Operation pressure range

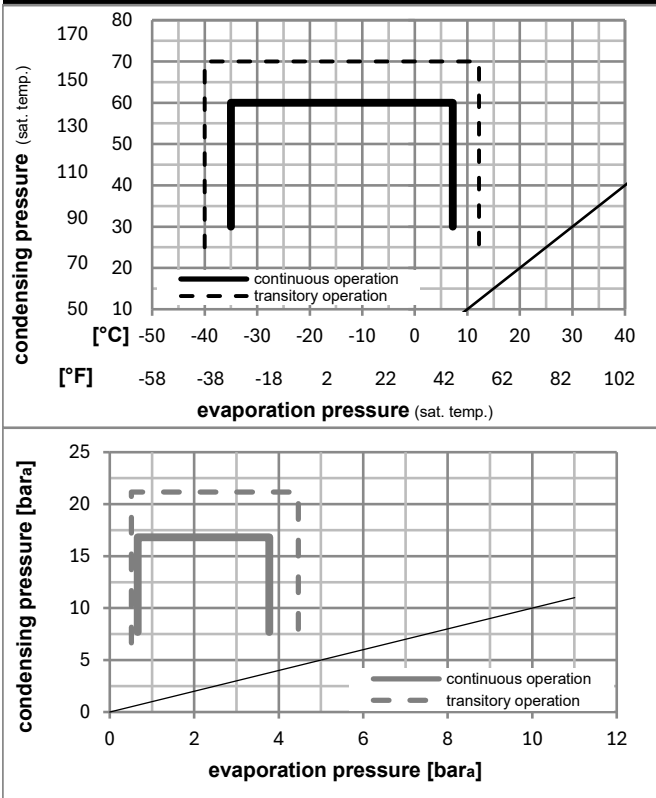

### Components (already pre-assembled)

a2	relay (protector: TI MRP30AEN-6)	117U4061
c	start capacitor (280µF)	117U5000
b	plastic cover	117U1021
d/dc	cord relief	117U0349

## Model

Designation **NF7.3FX.2** **115-127V/60Hz** Conf. 1 Sales code: **105G5719**

## Optimization + standard conditions

R134a, 115V/60Hz, CSIR, fan 1,5m/s, UL

	Evaporating pressure (saturation temperature)				Cooling capacity			COP	EER	P1	Power consumption		ASHRAE LBP	
	pe	pc	RGT	Tliq	[W]	[Btu/h]	[kcal/h]				I	m		
	[°C]	[°F]	[°C]	[°F]	[W]	[Btu/h]	[kcal/h]	[W/W]	[Btu/Wh]	[kcal/Wh]	[W]	[A]	[kg/h]	
	-23	54	32	32	261,5	893	225,1	1,16	3,95	1,00	226,0	3,57	5,08	ASHRAE LBP
	-10	130	90	90										
	-25	55	32	55	190,3	650	163,8	0,88	3,01	0,76	215,8	3,53	4,55	cecomaf LBP
	-13	131	90	131										
	-35	40	20	40	127,5	436	109,8	0,76	2,58	0,65	168,9	3,35	2,80	EN12900 LBP
	-31	104	68	104										
	-7	54	35	46	548,4	1873	472,0	1,70	5,82	1,47	322,1	4,12	11,97	ASHRAE MBP
	20	130	95	115										
	-10	55	32	55	425,5	1453	366,2	1,40	4,79	1,21	303,3	4,00	10,29	cecomaf MBP
	14	131	90	131										
	-10	45	20	45	479,2	1637	412,4	1,66	5,67	1,43	288,9	3,90	11,22	EN12900 MBP
	14	113	68	113										

## Performance tables

R134a, 115V/60Hz, CSIR, fan 1,5m/s, UL

	pe		Cooling capacity			COP	EER		P1	I	m
	[°C]	[°F]	[W]	[Btu/h]	[kcal/h]		[Btu/Wh]	[kcal/Wh]			
[°C / °F]	-35	-31	117,1	400	100,8	0,71	2,43	0,61	164,5	3,34	2,53
cond. pressure	-23	-10	257,3	879	221,4	1,14	3,89	0,98	225,7	3,54	5,58
pc= 45/113	-15	5	395,8	1352	340,6	1,49	5,10	1,28	265,1	3,75	8,63
return gas temp.	-9	15	509,4	1740	438,4	1,75	5,97	1,50	291,6	3,92	11,15
RGT= 32/90	-4	25	642,0	2193	552,5	2,01	6,87	1,73	319,4	4,10	14,14
liquid temp	0	32	747,2	2552	643,1	2,20	7,50	1,89	340,2	4,25	16,52
Tliq= 45/113	7,2	45	971,9	3319	836,4	2,53	8,66	2,18	383,5	4,54	21,71
[°C / °F]	-35	-31	91,4	312	78,6	0,61	2,07	0,52	150,7	3,30	2,17
cond. pressure	-23	-10	210,9	720	181,5	0,93	3,19	0,80	225,8	3,57	5,05
pc= 55/131	-15	5	333,8	1140	287,3	1,22	4,15	1,05	274,4	3,82	8,04
return gas temp	-9	15	436,6	1491	375,8	1,42	4,86	1,23	306,6	4,02	10,56
RGT= 32/90	-4	25	558,3	1907	480,5	1,64	5,61	1,41	339,8	4,23	13,59
liquid temp	0	32	655,6	2239	564,2	1,80	6,15	1,55	364,2	4,40	16,04
Tliq= 55/131	7,2	45	865,1	2955	744,5	2,09	7,14	1,80	413,7	4,73	21,40

### Model

Designation	<b>NF7.3FX.2</b>	<b>115-127V/60Hz</b>	<b>Conf. 2</b>	Sales code:	<b>105G5719</b>
-------------	------------------	----------------------	----------------	-------------	-----------------

### Configuration

Motorconfiguration	CSIR
Power supply (nominal)	115-127V/60Hz 1~
Refrigerant	R513A
Application	LBP+MBP
Voltage range	95-135V
Starting torque	HST
Approvals	UL

### Electrical accessories / wiring diagram

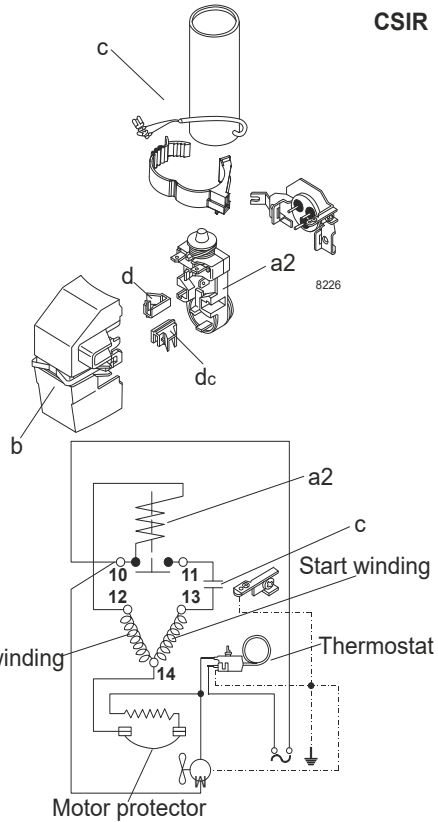

### Ambient/ machine room temperatures minimum /maximum

Ambient temperature range:	10 - 43°C / 50 - 110°F
Machine room temperature range:	10 - 48°C / 50 - 119°F
Compressor cooling:	fan 1,5m/s

### Operation pressure range

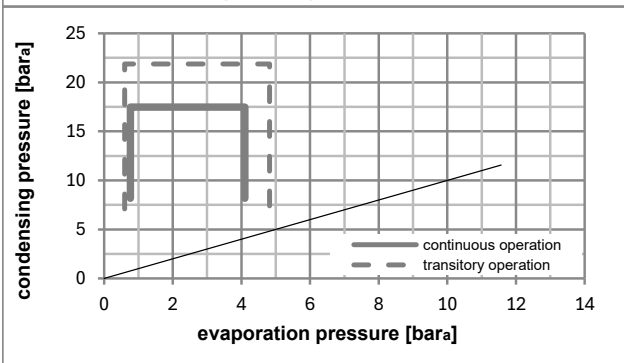
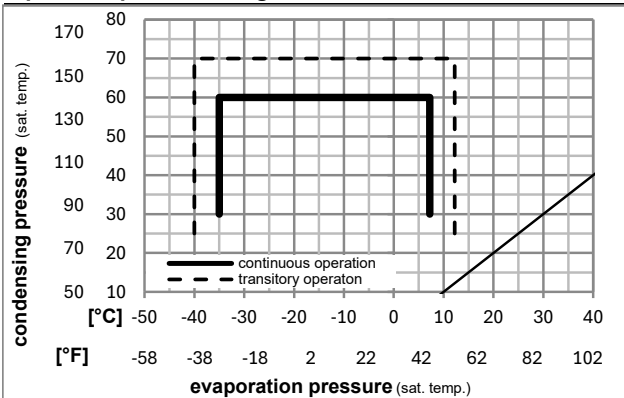

### Components (already pre-assembled)

a2	relay (protector: TI MRP30AEN-6)	117U4061
c	start capacitor (280µF)	117U5000
b	plastic cover	117U1021
d/dc	cord relief	117U0349

### Model

Designation	<b>NF7.3FX.2</b>	<b>115-127V/60Hz</b>	<b>Conf. 2</b>	Sales code:	<b>105G5719</b>
-------------	------------------	----------------------	----------------	-------------	-----------------

### Optimization + standard conditions

R513A, 115V/60Hz, CSIR, fan 1,5m/s, UL

	pe	pc	RGT	Tliq	Cooling capacity	COP	EER	P1	I	Ref. mass flow	
	[°C]	[°C]	[°C]	[°C]	[W]	[W/W]	[Btu/Wh]	[W]	[A]	[kg/h]	
	[°F]	[°F]	[°F]	[°F]	[Btu/h]	[kcal/h]	[kcal/Wh]	[W]	[A]	[kg/h]	
ASHRAE LBP	-23	54	32	32	289,1	1,18	4,04	244,1	3,88	6,22	
	-10	130	90	90							
cecomaf LBP	-25	55	32	55	204,8	0,88	2,99	233,8	3,81	5,61	
	-13	131	90	131							
EN12900 LBP	-35	40	20	40	142,4	0,78	2,66	182,9	3,68	3,52	
	-31	104	68	104							
ASHRAE MBP	-7	54	35	46	575,5	1,69	5,77	340,5	4,40	14,10	
	20	130	95	115							
cecomaf MBP	-10	55	32	55	441,3	1,37	4,68	322,0	4,30	12,20	
	14	131	90	131							
EN12900 MBP	-10	45	20	45	500,9	1,64	5,59	305,8	4,20	13,28	
	14	113	68	113							

### Performance tables

R513A, 115V/60Hz, CSIR, fan 1,5m/s, UL

	pe		Cooling capacity			COP	EER	P1	I	m
	[°C]	[°F]	[W]	[Btu/h]	[kcal/h]	[W/W]	[Btu/Wh]	[W]	[A]	[kg/h]
[°C / °F]	-35	-31	131,7	450	113,4	0,74	2,52	178,5	3,62	3,20
cond. pressure	-23	-10	278,6	951	239,8	1,15	3,92	242,4	3,92	6,80
pc= 45/113	-15	5	420,8	1437	362,1	1,49	5,09	282,2	4,09	10,31
return gas temp.	-9	15	536,1	1831	461,3	1,74	5,93	308,5	4,21	13,19
RGT= 32/90	-4	25	669,7	2287	576,3	1,99	6,81	336,0	4,35	16,55
liquid temp	0	32	775,0	2647	667,0	2,17	7,42	356,7	4,47	19,22
Tliq= 45/113	7,2	45	998,7	3411	859,5	2,50	8,53	399,9	4,74	24,98
[°C / °F]	-35	-31	102,6	351	88,3	0,62	2,12	165,6	3,39	2,80
cond. pressure	-23	-10	225,7	771	194,3	0,92	3,16	244,1	3,87	6,19
pc= 55/131	-15	5	349,7	1194	301,0	1,19	4,07	293,2	4,15	9,63
return gas temp	-9	15	452,3	1545	389,2	1,39	4,75	325,2	4,32	12,51
RGT= 32/90	-4	25	572,8	1956	492,9	1,60	5,46	358,1	4,50	15,93
liquid temp	0	32	668,7	2284	575,4	1,75	5,97	382,3	4,65	18,67
Tliq= 55/131	7,2	45	874,1	2985	752,3	2,03	6,92	431,5	4,95	24,64



8238-23

# NF Compressors

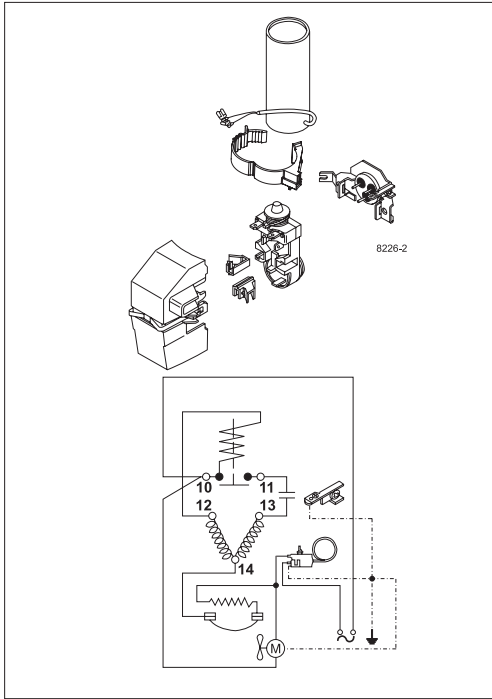
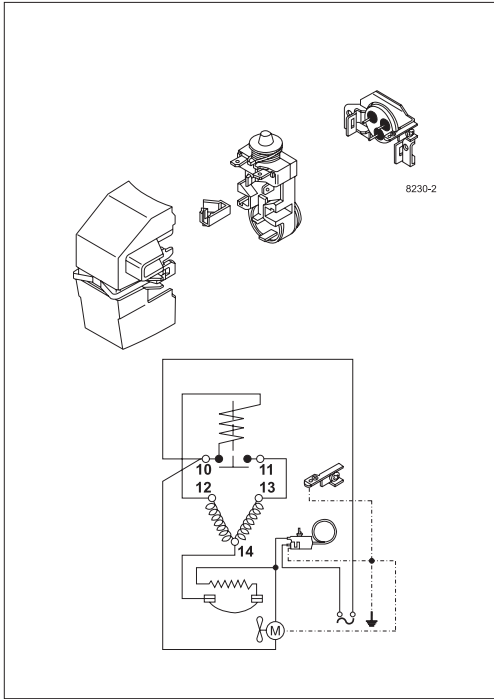



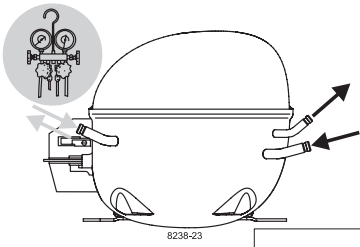

8238-23

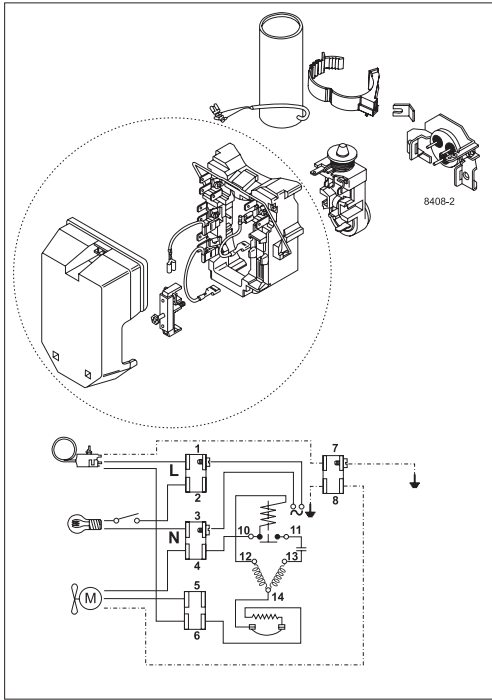
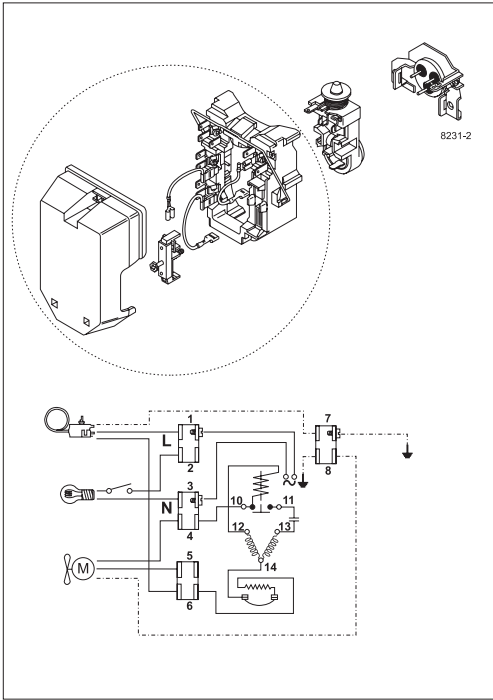

Secop accepts no responsibility for possible errors in catalogs, brochures, and other printed material. Secop reserves the right to alter its products without notice. This also applies to products already on order provided that such alterations can be made without subsequential changes being necessary to specifications already agreed. All trademarks in this material are the property of the respective companies. Secop and the Secop logotype are trademarks of Secop GmbH. All rights reserved. [www.secop.com](http://www.secop.com)