

Single Pack FR8.5G 220-240V 50/60Hz CSIR

Codice Imballo Singolo: **195B4032**

Posizione	Titolo	Codice	Quantità
1	Compressor FR8.5G	103G6780	1
2	Starting relay	117U6015	1
3	Starting capacitor (80 μ F 220V, 6.3mm)	117U5015	1
4	Cord relief	103N1010	1
5	Cover	103N2010	1
6	Bolt joint for one compressor M6 \varnothing 16mm	118-1917	1

Secop GmbH • Lise-Meitner-Straße 29 • 24941 Flensburg, Germany • Tel: +49 46149410 • www.secop.com

Secop non si assume alcuna responsabilità per eventuali errori presenti in cataloghi, brochure e altro materiale stampato. Secop si riserva il diritto di modificare i propri prodotti senza preavviso. Ciò vale anche per i prodotti già ordinati, a condizione che tali modifiche possano essere apportate senza che siano necessarie modifiche successive alle specifiche già concordate. Tutti i marchi presenti in questo materiale sono di proprietà delle rispettive aziende. Secop e il logo Secop sono marchi di Secop GmbH. Tutti i diritti sono riservati.

FR8.5G Universal Compressor R134a 220-240V 50/60Hz

General

Code number	103G6780
Approvals	EN 60335-2-34, UL984, CCC
Compressors on pallet	80

Application

Application	LBP/HBP	LBP
Frequency	Hz 50	60
Evaporating temperature	°C -30 to 10	-30 to -10
Voltage range	V 187 - 254	198 - 254
Max. condensing temperature continuous (short)	°C 60 (70)	60 (70)
Max. winding temperature continuous (short)	°C 125 (135)	125 (135)

Cooling requirements

Frequency	Hz	50			60		
Application		LBP	MBP	HBP	LBP	MBP	HBP
32°C		S	F ₂	F ₂	S	-	-
38°C		S	F ₂	F ₂	S	-	-
43°C		F ₁	F ₂	F ₂	F ₁	-	-

Remarks on application: HBP at 198 - 254V 50Hz only.

Motor

Motor type		RSIR/CSIR	
LRA (rated after 4 sec. UL984), HST LST	A	8.2	8.1
Cut in Current, HST LST	A	8.2	12.8
Resistance, main start winding (25°C)	Ω	8.9	12.0

Design

Displacement	cm ³	7.95
Oil quantity (type)	cm ³	450 (polyolester)
Maximum refrigerant charge	g	900
Free gas volume in compressor	cm ³	1350
Weight without electrical equipment	kg	10.6

Dimensions

Height	mm	A	196
		B	191
		B1	-
		B2	-
Suction connector	location/I.D. mm angle	C	8.2 30°
	material comment		Cu-plated steel Al cap
Process connector	location/I.D. mm angle	D	6.2 30°
	material comment		Cu-plated steel Al cap
Discharge connector	location/I.D. mm angle	E	6.2 25°
	material comment		Cu-plated steel Al cap
Oil cooler connector	location/I.D. mm angle	F	-
	material comment		-
Connector tolerance	I.D. mm		±0.09
Remarks:			

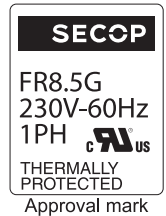
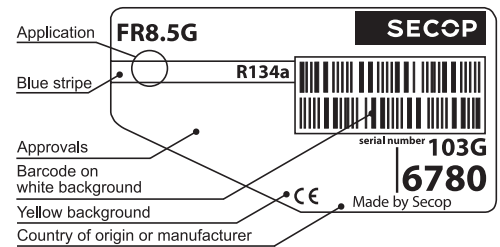

- S = Static cooling normally sufficient
- O = Oil cooling
- F₁ = Fan cooling 1.5 m/s (compressor compartment temperature equal to ambient temperature)
- F₂ = Fan cooling 3.0 m/s necessary
- SG = Suction gas cooling normally sufficient
- = not applicable in this area

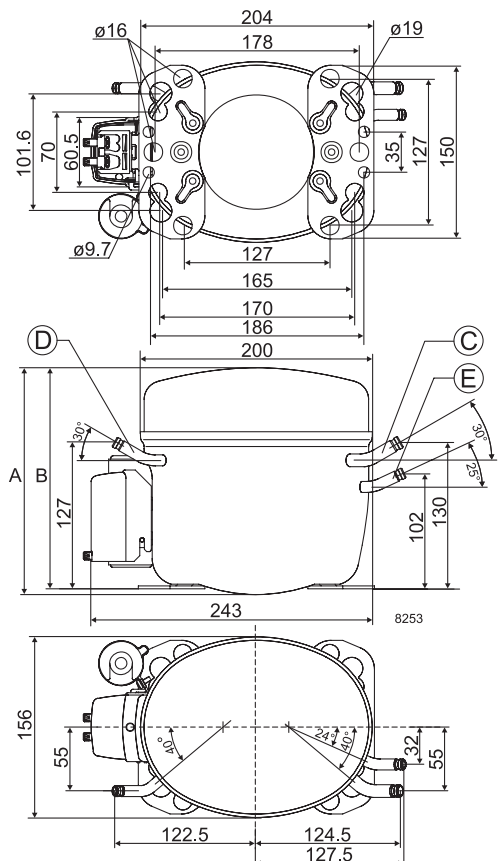

EN 12900 Household (CECOMAF) 220V, 50Hz, fan cooling F₂

Evap. temp. in °C	-45	-40	-35	-30	-25	-23.3	-20	-15	-10	-6.7	-5	0	5	7.2	10	15	20
Capacity in W				84.9	123	138	171	228	298	351	381	478	592	647	722		
Power cons. in W				127	151	159	176	203	231	251	261	291	321	335	352		
Current cons. in A				1.16	1.22	1.25	1.30	1.38	1.47	1.53	1.56	1.67	1.78	1.83	1.90		
COP in W/W				0.67	0.82	0.87	0.97	1.12	1.29	1.40	1.46	1.65	1.84	1.93	2.05		

EN 12900 Household (CECOMAF) 220V, 60Hz, fan cooling F₂

Evap. temp. in °C	-45	-40	-35	-30	-25	-23.3	-20	-15	-10	-6.7	-5	0	5	7.2	10	15	20
Capacity in W				92.3	138	156	195	263	345								
Power cons. in W				134	164	174	197	233	273								
Current cons. in A				1.02	1.12	1.16	1.24	1.37	1.53								
COP in W/W				0.69	0.85	0.90	0.99	1.13	1.26								

ASHRAE LBP 220V, 50Hz, fan cooling F₂

Evap. temp. in °C	-45	-40	-35	-30	-25	-23.3	-20	-15	-10	-6.7	-5	0	5	7.2	10	15	20
Capacity in W				105	152	171	211	282	368	434	471	592	734	803	898		
Power cons. in W				127	151	159	176	203	231	251	261	291	321	335	352		
Current cons. in A				1.16	1.22	1.25	1.30	1.38	1.47	1.53	1.56	1.67	1.78	1.83	1.90		
COP in W/W				0.83	1.01	1.07	1.19	1.39	1.59	1.73	1.81	2.04	2.29	2.40	2.55		

ASHRAE LBP 220V, 60Hz, fan cooling F₂

Evap. temp. in °C	-45	-40	-35	-30	-25	-23.3	-20	-15	-10	-6.7	-5	0	5	7.2	10	15	20
Capacity in W				114	171	193	241	325	426								
Power cons. in W				134	164	174	197	233	273								
Current cons. in A				1.02	1.12	1.16	1.24	1.37	1.53								
COP in W/W				0.85	1.04	1.11	1.22	1.39	1.56								

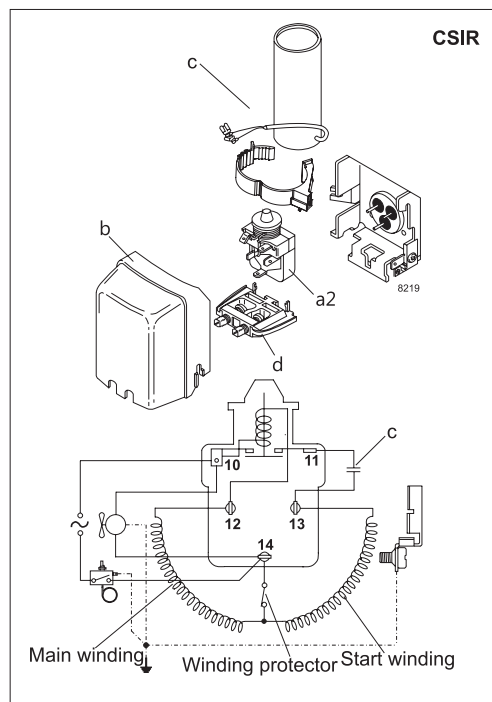

Accessories for	FR8.5G	Figure	Code number
PTC starting device	6.3 mm spade connectors	a1	103N0011
	4.8 mm spade connectors		103N0018
Starting relay	6.3 mm spade connectors	a2	117U6015
Start. capacitor 80 µF	6.3 mm spade connectors	c	117U5015
Cover		b	103N2010
Cord relief		d	103N1010
Protection screen for PTC		g	103N0476

Test conditions	EN 12900/CECOMAF	ASHRAE
Condensing temperature	55°C	55°C
Ambient temperature	32°C	32°C
Suction gas temperature	32°C	32°C
Liquid temperature	55°C	32°C

Mounting accessories		Code number
Bolt joint for one comp.	Ø: 16 mm	118-1917
Bolt joint in quantities	Ø: 16 mm	118-1918
Snap-on in quantities	Ø: 16 mm	118-1919

Secop accepts no responsibility for possible errors in catalogs, brochures, and other printed material. Secop reserves the right to alter its products without notice. This also applies to products already on order provided that such alterations can be made without substantial changes being necessary to specifications already agreed. All trademarks in this material are the property of the respective companies. Secop and the Secop logotype are trademarks of Secop GmbH. All rights reserved. www.secop.com