

## Single Pack SC12MLX 220-240V 50Hz / 208-230V 60Hz CSIR

Codice Imballo Singolo: **195B4051**

Posizione	Titolo	Codice	Quantità
1	Compressor SC12MLX	104L2606	1
2	Starting relay	117U6011	1
3	Starting capacitor (80 $\mu$ F 220V, 6.3mm)	117U5017	1
4	Cord relief	103N1004	1
5	Cover	103N2008	1
6	Bolt joint for one compressor   M6   $\varnothing$ 16mm	118-1917	1

Secop GmbH • Lise-Meitner-Straße 29 • 24941 Flensburg, Germany • Tel: +49 46149410 • [www.secop.com](http://www.secop.com)

Secop non si assume alcuna responsabilità per eventuali errori presenti in cataloghi, brochure e altro materiale stampato. Secop si riserva il diritto di modificare i propri prodotti senza preavviso. Ciò vale anche per i prodotti già ordinati, a condizione che tali modifiche possano essere apportate senza che siano necessarie modifiche successive alle specifiche già concordate. Tutti i marchi presenti in questo materiale sono di proprietà delle rispettive aziende. Secop e il logo Secop sono marchi di Secop GmbH. Tutti i diritti sono riservati.

## Model

Designation	<b>SC12MLX</b>	220-240V/50Hz 1~ 208-230V/60Hz 1~	Sales code:	<b>104L2606</b>
-------------	----------------	-----------------------------------	-------------	-----------------

## Compressor design

Oil type	Polyolester	Refrigerant(s)	<b>R404A, R452A, R507</b>
Oil viscosity	32cST	Displacement	12,87cm <sup>3</sup> / 0,79cu.in
Oil quantity	555cm <sup>3</sup> / 18,8fl.oz	Compressors on pallet	80
Refr. charge - tech. limit	1300g / 45,9oz		
Free gas volume comp.	1410cm <sup>3</sup> / 47,7fl.oz		
Weight	13kg / 28,7lbs		
Motor protection	1# internal		
Winding resistance main	3,4Ω (at 25°C)		
Winding resistance aux	14,4Ω (at 25°C)		
Max. winding temp.	125°C / 257°F		
Max. discharge temp.	130°C / 266°F		



## General - Configurations with SC12MLX

	<b>Conf. 1</b>	<b>Conf. 2</b>	<b>Conf. 3</b>	<b>Conf. 4</b>	<b>Conf. 5</b>
Motorconfiguration	CSIR	CSIR	CSIR	CSIR	CSIR
Power supply (nominal)	220-240V/50Hz	208-230V/60Hz	220-240V/50Hz	220-240V/50Hz	220-240V/50Hz
Number of phases	1	1	1	1	1
Voltage range	187-254V	187-254V	187-254V	187-254V	187-254V
Approvals	VDE, UL, CCC, EAC, KC	VDE, UL, CCC, EAC, KC	VDE, UL, CCC		
Starting torque	HST	HST	HST	HST	HST
Note	- / -				

## Applications with SC12MLX

	<b>Conf. 1</b>	<b>Conf. 2</b>	<b>Conf. 3</b>	<b>Conf. 4</b>	<b>Conf. 5</b>
Refrigerant	R404A	R404A	R452A	R448A	R449A
Application	MBP	MBP	MBP	MBP	MBP
System cooling	fan 3m/s	fan 3m/s	fan 3m/s	fan 3m/s	fan 3m/s
Hot gas defrost	OK	OK	OK	OK	OK
Long interval pull down	OK	OK	OK	OK	OK

## Electrical data - Configurations with SC12MLX

	<b>Conf. 1</b>	<b>Conf. 2</b>	<b>Conf. 3</b>	<b>Conf. 4</b>	<b>Conf. 5</b>
Starting device type	relay	relay	relay	relay	relay
Run capacitor	- / -	- / -	- / -	- / -	- / -
Start capacitor	80μF	80μF	80μF	80μF	80μF
LRA (locked rotor amps / 4s)	23,4A	23,4A	23,4A	23,4A	23,4A
RLA (rated load amps / 1s)	4,3A	4,3A	4,3A	4,3A	4,3A
Cut in current	23,4A	23,4A	23,4A	23,4A	23,4A

## Model

Designation

**SC12MLX**

220-240V/50Hz 1~ 208-230V/60Hz 1~

Sales code:

**104L2606**

## Compressor dimensions

Housing	A Height	219mm / 8,62in
	B Height	213mm / 8,39in
	C Length shell	218mm / 8,58in
	D Length w. cover	255mm / 10,04in
	E Width	151mm / 5,94in

Connectors	Suction X	Discharge Y	Process Z
Diameter [mm]	øi 8,11-8,29	øi 6,41-6,59	øi 6,41-6,59
(i:inside, o:outside) [in]	øi 0,32-0,33	øi 0,25-0,26	øi 0,25-0,26
Material	copper	copper	copper
Horizontal angle ±2°	37°	37°	143°
Vertical angle ±2°	30°	0°	150°
Position l/h/w [mm]	107/193/55	115/110/63	-107/193/55
[in]	4,2/7,6/2,2	4,5/4,3/2,5	-4,2/7,6/2,2
Straight tube l. [mm]	12	12	12
[in]	0,5	0,5	0,5



## Compressor fixation



## Bolt joint



## Snap-on



## Mounting accessories

Mounting accessories	one comp.	multi pack
Bolt joint   M6   ø16mm	118-1917	118-1918
Bolt joint   ø1/4"   ø16mm	118-1946	
Bolt joint   ø1/4"   ø19mm	118-1949	
Snap-on   ø7,3   ø16mm	118-1947	118-1919

## Application notes

LRA value on compressor label and datasheet may differ due to different test conditions for UL approval.

Provision for PE Grounding is located at the PE Stamp on the compressor

## Model

Designation	<b>SC12MLX</b>	<b>220-240V/50Hz</b>	<b>Conf. 1</b>	Sales code:	<b>104L2606</b>
-------------	----------------	----------------------	----------------	-------------	-----------------

## Configuration

Motorconfiguration	CSIR
Power supply (nominal)	220-240V/50Hz 1~
Refrigerant	R404A
Application	MBP
Voltage range	187-254V
Starting torque	HST
Approvals	VDE UL CCC EAC KC

## Electrical accessories / wiring diagram



## Ambient/ machine room temperatures minimum /maximum

Ambient temperature range:	10 - 43°C / 50 - 110°F
Machine room temperature range:	10 - 48°C / 50 - 119°F
Compressor cooling:	fan 3m/s

## Operation Limits

### Operation pressure range

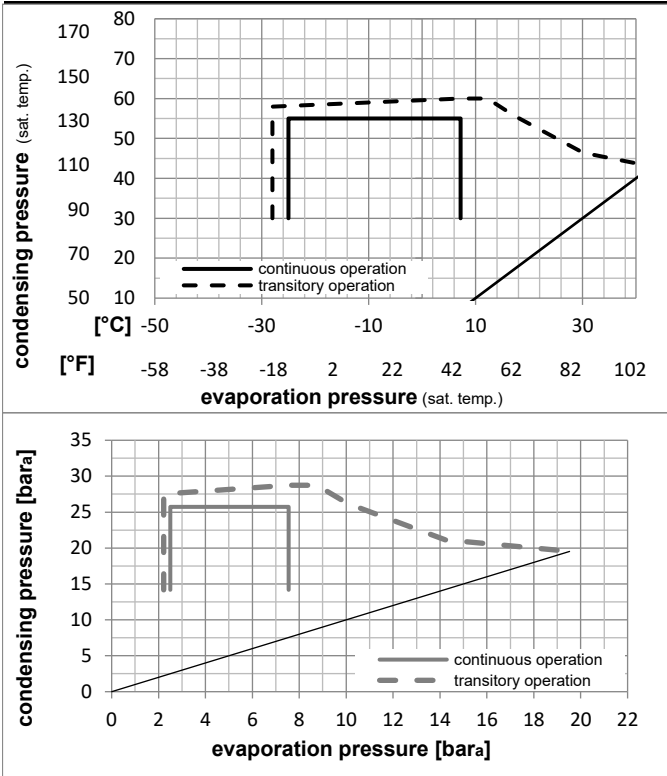

### Components

a2	relay	117U6011
c	start capacitor (80μF)	117U5017
d	cord relief	103N1004
b	plastic cover	103N2008

### Model

Designation **SC12MLX 220-240V/50Hz** Conf. 1 Sales code: **104L2606**

### Optimization + standard conditions

R404A, 220V/50Hz, CSIR, fan 3m/s, VDE, UL, CCC, EAC, KC

	Evaporating pressure (saturation temperature)				Condensing pressure (saturation temperature)			COP	EER			Power consumption			ASHRAE MBP
	pe	pc	RGT	Tliq	[W]	[Btu/h]	[kcal/h]		[W/W]	[Btu/Wh]	[kcal/Wh]	P1	I	Ref. mass flow	
[°C]	-7	54	35	46	1097,6	3749	944,6	1,56	5,31	1,34	705,6	4,40	30,20		
[°F]	20	130	95	115											
	-10	55	32	55	815,0	2784	701,4	1,22	4,15	1,05	670,1	4,26	26,09	cecomaf MBP	
	-10	45	20	45	978,0	3340	841,7	1,58	5,39	1,36	619,6	4,08	29,46	EN12900 MBP	
	-10	49	18	49	1013,5	3461	872,2	1,51	5,14	1,30	673,3	4,28	33,12	ARI540 MBP	
	-10	45	32	45	1037,9	3545	893,2	1,68	5,72	1,44	619,6	4,08	28,58	opt	
	-25	45	32	45	527,1	1800	453,6	1,11	3,78	0,95	476,0	3,63	14,22	opt	

### Performance tables

R404A, 220V/50Hz, CSIR, fan 3m/s, VDE, UL, CCC, EAC, KC

	pe		Cooling capacity			COP	EER		P1	I	m
	[°C]	[°F]	[W]	[Btu/h]	[kcal/h]	[W/W]	[Btu/Wh]	[kcal/Wh]	[W]	[A]	[kg/h]
[°C / °F]	-25	-13	527,1	1800	453,6	1,11	3,78	0,95	476,0	3,63	14,22
cond. pressure	-20	-4	668,6	2283	575,4	1,27	4,35	1,10	524,7	3,76	18,14
pc= 45/113	-15	5	837,9	2862	721,1	1,46	5,00	1,26	572,4	3,91	22,89
return gas temp.	-10	14	1037,9	3545	893,2	1,68	5,72	1,44	619,6	4,08	28,58
RGT= 32/90	-5	23	1271,6	4343	1094,4	1,91	6,51	1,64	666,6	4,27	35,35
liquid temp	0	32	1541,9	5266	1327,0	2,16	7,38	1,86	713,9	4,47	43,35
Tliq= 45/113	7,2	45	2001,3	6835	1722,3	2,55	8,73	2,20	783,3	4,79	57,39
[°C / °F]	-25	-13	390,8	1335	336,3	0,80	2,75	0,69	485,7	3,66	12,21
cond. pressure	-20	-4	511,5	1747	440,2	0,93	3,18	0,80	549,4	3,84	16,09
pc= 55/131	-15	5	651,9	2226	561,0	1,07	3,65	0,92	610,7	4,04	20,67
return gas temp	-10	14	815,0	2784	701,4	1,22	4,15	1,05	670,1	4,26	26,09
RGT= 32/90	-5	23	1003,8	3428	863,9	1,38	4,71	1,19	727,9	4,49	32,49
liquid temp	0	32	1221,2	4170	1050,9	1,56	5,32	1,34	784,6	4,74	40,05
Tliq= 55/131	7,2	45	1590,2	5431	1368,6	1,84	6,28	1,58	865,1	5,13	53,37

## Model

Designation	<b>SC12MLX</b>	<b>208-230V/60Hz</b>	<b>Conf. 2</b>	Sales code:	<b>104L2606</b>
-------------	----------------	----------------------	----------------	-------------	-----------------

## Configuration

Motorconfiguration	CSIR
Power supply (nominal)	208-230V/60Hz 1~
Refrigerant	R404A
Application	MBP
Voltage range	187-254V
Starting torque	HST
Approvals	VDE UL CCC EAC KC

## Electrical accessories / wiring diagram

CSIR



## Ambient/ machine room temperatures minimum /maximum

Ambient temperature range:	10 - 43°C / 50 - 110°F
Machine room temperature range:	10 - 48°C / 50 - 119°F
Compressor cooling:	fan 3m/s

## Operation Limits

## Operation pressure range

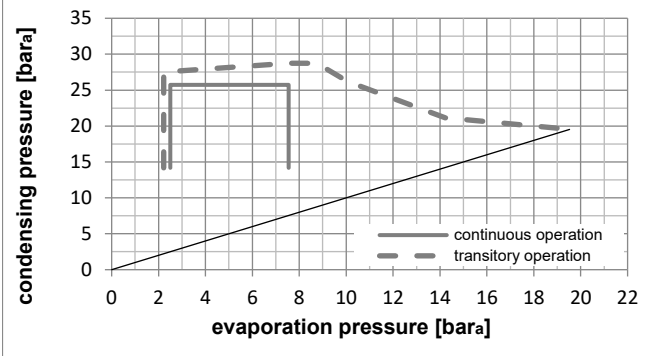
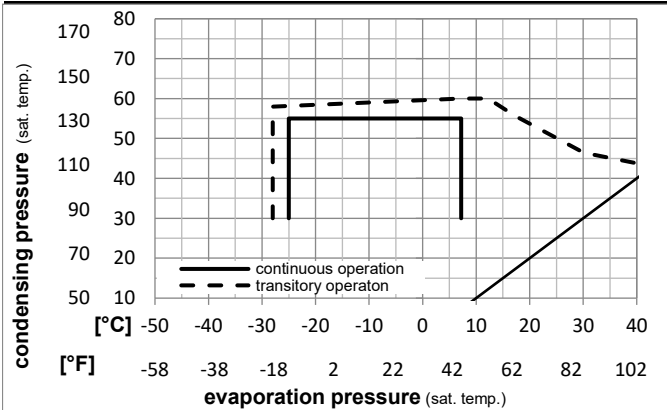

## Components

a2	relay	117U6011
c	start capacitor (80μF)	117U5017
d	cord relief	103N1004
b	plastic cover	103N2008

## Model

Designation **SC12MLX** **208-230V/60Hz** Conf. 2 Sales code: **104L2606**

## Optimization + standard conditions

R404A, 220V/60Hz, CSIR, fan 3m/s, VDE, UL, CCC, EAC, KC

		Evaporating pressure (saturation temperature)				Condensing pressure (saturation temperature)						Power consumption			
		Return gas temp.		Liquid temp.		Cooling capacity		COP	EER		P1	I	Ref. mass flow		
		pe	pc	RGT	Tliq	[W]	[Btu/h]	[kcal/h]	[W/W]	[Btu/Wh]	[kcal/Wh]	[W]	[A]	[kg/h]	
[°C]	-7	54	35	46	1261,1	4307	1085,3	1,52	5,18	1,31	831,3	4,47	34,70	ASHRAE MBP	
[°F]	20	130	95	115											
[°C]	-10	55	32	55	934,4	3191	804,1	1,20	4,10	1,03	777,8	4,23	29,91	cecomaf MBP	
[°F]	14	131	90	131											
[°C]	-10	45	20	45	1130,1	3859	972,6	1,55	5,29	1,33	729,5	4,05	34,04	EN12900 MBP	
[°F]	14	113	68	113											
[°C]	-7	49	18	49	1165,3	3980	1002,8	1,46	4,98	1,26	798,8	4,34	38,08	ARI540 MBP	
[°F]	20	120	65	120											
[°C]	-10	45	32	45	1199,3	4096	1032,2	1,64	5,62	1,41	729,5	4,05	33,03	opt	
[°F]	14	113	90	113											
[°C]	-25	45	32	45	604,9	2066	520,6	1,12	3,83	0,97	539,3	3,31	16,32	opt	
[°F]	-13	113	90	113											

## Performance tables

R404A, 220V/60Hz, CSIR, fan 3m/s, VDE, UL, CCC, EAC, KC

	pe		Cooling capacity			COP	EER	P1	I	m	
	[°C]	[°F]	[W]	[Btu/h]	[kcal/h]	[W/W]	[Btu/Wh]	[kcal/Wh]	[W]	[A]	[kg/h]
[°C / °F]	-25	-13	604,9	2066	520,6	1,12	3,83	0,97	539,3	3,31	16,32
cond. pressure	-20	-4	773,0	2640	665,3	1,29	4,39	1,11	601,5	3,52	20,97
pc= 45/113	-15	5	970,0	3313	834,8	1,46	4,99	1,26	663,9	3,76	26,50
return gas temp.	-10	14	1199,3	4096	1032,2	1,64	5,62	1,41	729,5	4,05	33,03
RGT= 32/90	-5	23	1464,7	5002	1260,6	1,83	6,24	1,57	801,2	4,37	40,72
liquid temp	0	32	1769,7	6044	1523,1	2,01	6,85	1,73	882,1	4,73	49,75
Tliq= 45/113	7,2	45	2285,8	7807	1967,2	2,24	7,65	1,93	1020,6	5,32	65,55
[°C / °F]	-25	-13	429,8	1468	369,9	0,83	2,83	0,71	518,9	3,31	13,43
cond. pressure	-20	-4	575,6	1966	495,4	0,95	3,23	0,81	608,5	3,58	18,11
pc= 55/131	-15	5	742,6	2536	639,1	1,07	3,66	0,92	693,8	3,88	23,55
return gas temp	-10	14	934,4	3191	804,1	1,20	4,10	1,03	777,8	4,23	29,91
RGT= 32/90	-5	23	1154,5	3943	993,6	1,34	4,57	1,15	863,3	4,61	37,37
liquid temp	0	32	1406,6	4804	1210,6	1,48	5,04	1,27	953,5	5,03	46,13
Tliq= 55/131	7,2	45	1833,2	6261	1577,6	1,67	5,70	1,44	1097,4	5,71	61,52

## Model

Designation	<b>SC12MLX</b>	<b>220-240V/50Hz</b>	<b>Conf. 3</b>	Sales code:	<b>104L2606</b>
-------------	----------------	----------------------	----------------	-------------	-----------------

## Configuration

Motorconfiguration	CSIR
Power supply (nominal)	220-240V/50Hz 1~
Refrigerant	R452A
Application	MBP
Voltage range	187-254V
Starting torque	HST
Approvals	VDE UL CCC

## Electrical accessories / wiring diagram



## Ambient/ machine room temperatures minimum /maximum

Ambient temperature range:	10 - 43°C / 50 - 110°F
Machine room temperature range:	10 - 48°C / 50 - 119°F
Compressor cooling:	fan 3m/s

## Operation Limits

## Operation pressure range

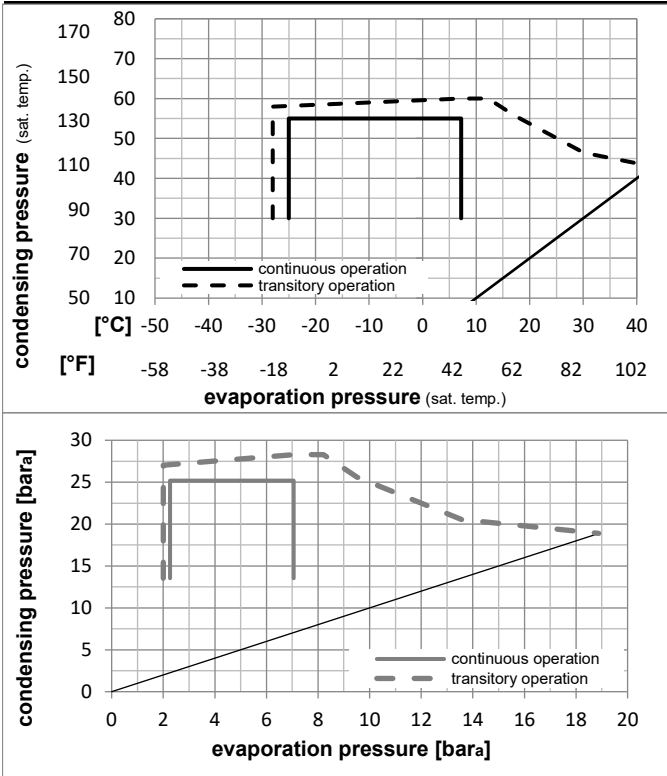

## Components

a2	relay	117U6011
c	start capacitor (80μF)	117U5017
d	cord relief	103N1004
b	plastic cover	103N2008



### Model

Designation **SC12MLX** **220-240V/50Hz** Conf. 3 Sales code: **104L2606**

### Optimization + standard conditions

R452A, 220V/50Hz, CSIR, fan 3m/s, VDE, UL, CCC

		Evaporating pressure (saturation temperature)				Condensing pressure (saturation temperature)						Power consumption					
		Return gas temp.				Liquid temp.						Current consumption			Ref. mass flow		
		Cooling capacity				COP	EER	P1			I	m					
		pe	pc	RGT	Tliq	[W]	[Btu/h]	[kcal/h]	[W/W]	[Btu/Wh]	[kcal/Wh]	[W]	[A]	[kg/h]			
[°C]	[°F]																
-7	20	54	130	35	95	46	115	1036,0	3538	891,6	1,53	5,23	1,32	676,2	4,30	29,14	ASHRAE MBP
-10	14	55	131	32	90	55	131	770,7	2632	663,3	1,21	4,12	1,04	639,5	4,19	25,05	cecomaf MBP
-10	14	45	113	20	68	45	113	921,8	3148	793,3	1,56	5,32	1,34	591,9	4,04	28,33	EN12900 MBP
-7	20	49	120	18	65	49	120	961,6	3284	827,6	1,49	5,09	1,28	645,5	4,20	31,90	ARI540 MBP
-10	14	45	113	32	90	45	113	976,8	3336	840,7	1,65	5,64	1,42	591,9	4,04	27,52	opt
-25	-13	45	113	32	90	45	113	484,7	1655	417,1	1,08	3,71	0,93	446,7	3,59	13,41	opt

### Performance tables

R452A, 220V/50Hz, CSIR, fan 3m/s, VDE, UL, CCC

	pe		Cooling capacity			COP	EER	P1			I	m
	[°C]	[°F]	[W]	[Btu/h]	[kcal/h]	[W/W]	[Btu/Wh]	[kcal/Wh]	[W]	[A]	[kg/h]	
[°C / °F]	-25	-13	484,7	1655	417,1	1,08	3,71	0,93	446,7	3,59	13,41	
cond. pressure	-20	-4	620,3	2119	533,9	1,25	4,28	1,08	495,5	3,74	17,25	
pc= 45/113	-15	5	783,4	2675	674,2	1,44	4,92	1,24	543,8	3,89	21,91	
return gas temp.	-10	14	976,8	3336	840,7	1,65	5,64	1,42	591,9	4,04	27,52	
RGT= 32/90	-5	23	1203,8	4111	1036,0	1,88	6,42	1,62	640,2	4,19	34,21	
liquid temp	0	32	1467,4	5012	1262,9	2,13	7,27	1,83	689,1	4,34	42,12	
Tliq= 45/113	7,2	45	1917,5	6549	1650,2	2,52	8,60	2,17	761,1	4,56	56,02	
[°C / °F]	-25	-13	359,7	1228	309,6	0,79	2,71	0,68	454,1	3,61	11,45	
cond. pressure	-20	-4	475,7	1625	409,4	0,92	3,14	0,79	517,5	3,81	15,23	
pc= 55/131	-15	5	611,7	2089	526,5	1,06	3,61	0,91	579,2	4,00	19,72	
return gas temp.	-10	14	770,7	2632	663,3	1,21	4,12	1,04	639,5	4,19	25,05	
RGT= 32/90	-5	23	955,7	3264	822,5	1,37	4,67	1,18	698,8	4,37	31,37	
liquid temp	0	32	1169,9	3995	1006,8	1,54	5,28	1,33	757,4	4,55	38,84	
Tliq= 55/131	7,2	45	1535,6	5244	1321,6	1,83	6,23	1,57	841,2	4,81	52,05	

## Model

Designation	<b>SC12MLX</b>	<b>220-240V/50Hz</b>	<b>Conf. 4</b>	Sales code:	<b>104L2606</b>
-------------	----------------	----------------------	----------------	-------------	-----------------

## Configuration

Motorconfiguration	CSIR
Power supply (nominal)	220-240V/50Hz 1~
Refrigerant	R448A
Application	MBP
Voltage range	187-254V
Starting torque	HST
Approvals	

## Electrical accessories / wiring diagram

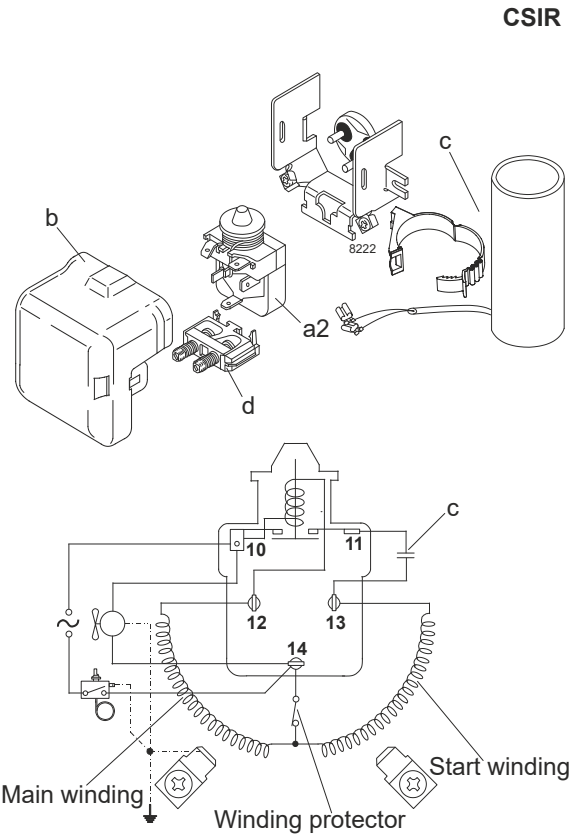

## Ambient/ machine room temperatures minimum /maximum

Ambient temperature range:	10 - 38°C / 50 - 101°F
Machine room temperature range:	10 - 43°C / 50 - 110°F
Compressor cooling:	fan 3m/s

## Operation Limits

## Operation pressure range

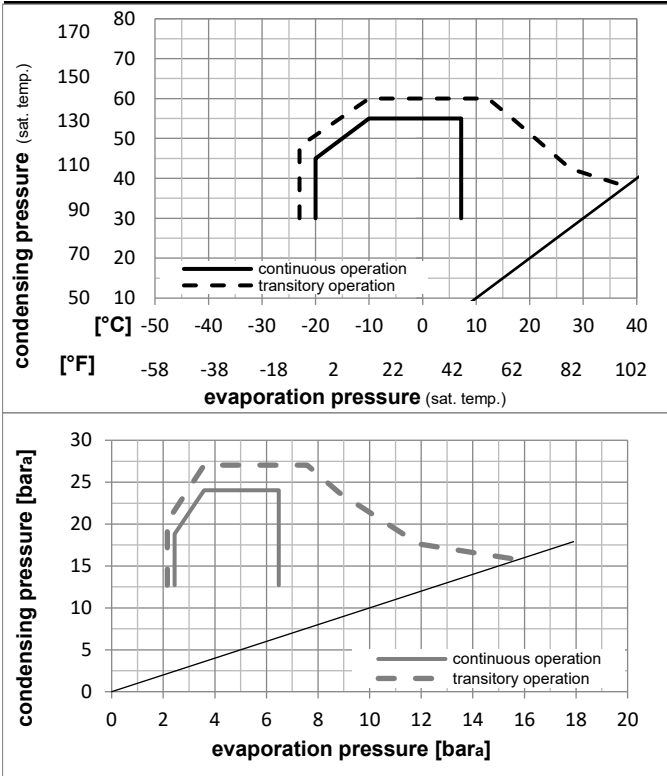

## Components

a2	relay	117U6011
c	start capacitor (80μF)	117U5017
d	cord relief	103N1004
b	plastic cover	103N2008

### Model

Designation **SC12MLX** **220-240V/50Hz** Conf. 4 Sales code: **104L2606**

### Optimization + standard conditions

R448A, 220V/50Hz, CSIR, fan 3m/s,

		Evaporating pressure (saturation temperature)				Condensing pressure (saturation temperature)					Power consumption				
		Return gas temp.				Liquid temp.					Current consumption				
		Cooling capacity				COP	EER		P1	I	Ref. mass flow				
		pe	pc	RGT	Tliq	[W]	[Btu/h]	[kcal/h]	[W/W]	[Btu/Wh]	[kcal/Wh]	[W]	[A]	[kg/h]	
[°C]	-7	54	35	46	1000,1	3416	860,7	1,55	5,30	1,33	644,8	4,23	21,85	ASHRAE MBP	
[°F]	20	130	95	115											
[°C]	-10	55	32	55	763,5	2608	657,1	1,26	4,29	1,08	608,1	4,09	18,70	cecomaf MBP	
[°F]	14	131	90	131											
[°C]	-10	45	20	45	902,8	3083	776,9	1,61	5,49	1,38	561,6	3,93	21,12	EN12900 MBP	
[°F]	14	113	68	113											
[°C]	-7	49	18	49	960,3	3280	826,4	1,56	5,33	1,34	614,8	4,12	23,88	ARI540 MBP	
[°F]	20	120	65	120											
[°C]	-10	45	32	45	939,4	3208	808,5	1,67	5,71	1,44	561,6	3,93	20,53	opt	
[°F]	14	113	90	113											
[°C]	-25	45	32	45	455,4	1555	392,0	1,09	3,73	0,94	416,7	3,41	9,79	opt	
[°F]	-13	113	90	113											

### Performance tables

R448A, 220V/50Hz, CSIR, fan 3m/s,

	pe		Cooling capacity			COP	EER		P1	I	m
	[°C]	[°F]	[W]	[Btu/h]	[kcal/h]	[W/W]	[Btu/Wh]	[kcal/Wh]	[W]	[A]	[kg/h]
[°C / °F]	-20	-4	587,7	2007	505,8	1,26	4,31	1,09	465,2	3,58	12,69
cond. pressure	-15	5	747,9	2554	643,6	1,46	4,98	1,25	513,4	3,75	16,24
pc= 45/113	-10	14	939,4	3208	808,5	1,67	5,71	1,44	561,6	3,93	20,53
return gas temp.	-7	20	1084,7	3704	933,5	1,83	6,24	1,57	593,6	4,04	23,81
RGT= 32/90	-5	23	1165,8	3981	1003,3	1,91	6,52	1,64	610,2	4,10	25,66
liquid temp	0	32	1430,5	4885	1231,1	2,17	7,41	1,87	659,6	4,28	31,77
Tliq= 45/113	7,2	45	1885,9	6441	1623,1	2,57	8,79	2,22	732,6	4,54	42,54
[°C / °F]	-20	-4	463,9	1584	399,2	0,95	3,25	0,82	487,1	3,66	11,21
cond. pressure	-15	5	601,3	2054	517,5	1,10	3,75	0,94	548,1	3,88	14,62
pc= 55/131	-10	14	763,5	2608	657,1	1,26	4,29	1,08	608,1	4,09	18,70
return gas temp	-7	20	885,8	3025	762,3	1,37	4,67	1,18	647,3	4,24	21,81
RGT= 32/90	-5	23	953,9	3258	820,9	1,43	4,88	1,23	667,5	4,31	23,56
liquid temp	0	32	1176,0	4016	1012,0	1,62	5,53	1,39	726,4	4,52	29,33
Tliq= 55/131	7,2	45	1558,3	5322	1341,1	1,92	6,56	1,65	811,3	4,83	39,55

## Model

Designation	<b>SC12MLX</b>	<b>220-240V/50Hz</b>	<b>Conf. 5</b>	Sales code:	<b>104L2606</b>
-------------	----------------	----------------------	----------------	-------------	-----------------

## Configuration

Motorconfiguration	CSIR
Power supply (nominal)	220-240V/50Hz 1~
Refrigerant	R449A
Application	MBP
Voltage range	187-254V
Starting torque	HST
Approvals	

## Electrical accessories / wiring diagram

CSIR

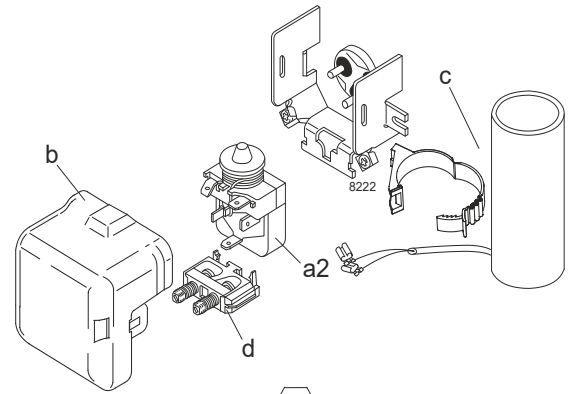

## Ambient/ machine room temperatures minimum /maximum

Ambient temperature range:	10 - 38°C / 50 - 101°F
Machine room temperature range:	10 - 43°C / 50 - 110°F
Compressor cooling:	fan 3m/s

## Operation Limits

### Operation pressure range

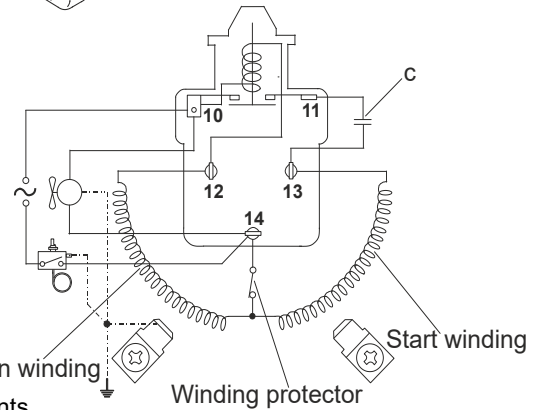
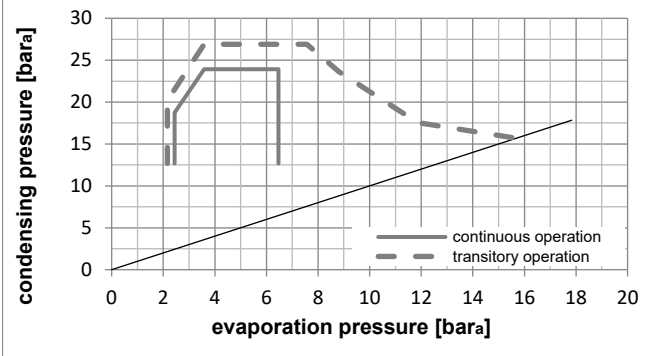
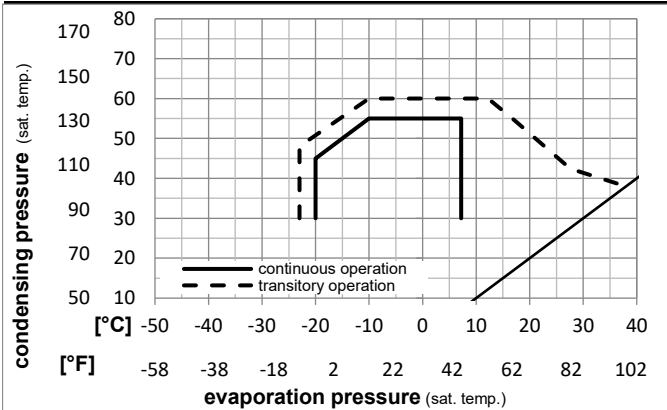

### Components

a2	relay	117U6011
c	start capacitor (80μF)	117U5017
d	cord relief	103N1004
b	plastic cover	103N2008

### Model

Designation **SC12MLX** **220-240V/50Hz** Conf. 5 Sales code: **104L2606**

### Optimization + standard conditions

R449A, 220V/50Hz, CSIR, fan 3m/s,

		Evaporating pressure (saturation temperature)				Condensing pressure (saturation temperature)						Power consumption			
		Return gas temp.				Liquid temp.						Current consumption			Ref. mass flow
		Cooling capacity				COP	EER		P1	I	m				
		pe	pc	RGT	Tliq	[W]	[Btu/h]	[kcal/h]	[W/W]	[Btu/Wh]	[kcal/Wh]	[W]	[A]	[kg/h]	
[°C]	-7	54	35	46	994,6	3397	856,0	1,55	5,29	1,33	641,5	4,22	22,15	ASHRAE MBP	
[°F]	20	130	95	115											
[°C]	-10	55	32	55	758,4	2590	652,7	1,25	4,28	1,08	605,2	4,08	18,97	cecomaf MBP	
[°F]	14	131	90	131											
[°C]	-10	45	20	45	896,8	3063	771,8	1,60	5,48	1,38	559,3	3,92	21,42	EN12900 MBP	
[°F]	14	113	68	113											
[°C]	-7	49	18	49	953,0	3255	820,2	1,56	5,32	1,34	611,9	4,11	24,22	ARI540 MBP	
[°F]	20	120	65	120											
[°C]	-10	45	32	45	934,2	3190	803,9	1,67	5,70	1,44	559,3	3,92	20,82	opt	
[°F]	14	113	90	113											
[°C]	-25	45	32	45	453,5	1549	390,3	1,09	3,73	0,94	415,6	3,40	9,94	opt	
[°F]	-13	113	90	113											

### Performance tables

R449A, 220V/50Hz, CSIR, fan 3m/s,

	pe		Cooling capacity			COP	EER		P1	I	m
	[°C]	[°F]	[W]	[Btu/h]	[kcal/h]	[W/W]	[Btu/Wh]	[kcal/Wh]	[W]	[A]	[kg/h]
[°C / °F]	-20	-4	584,9	1997	503,4	1,26	4,31	1,09	463,7	3,57	12,88
cond. pressure	-15	5	744,0	2541	640,3	1,45	4,97	1,25	511,4	3,75	16,47
pc= 45/113	-10	14	934,2	3190	803,9	1,67	5,70	1,44	559,3	3,92	20,82
return gas temp.	-7	20	1078,4	3683	928,1	1,82	6,23	1,57	591,0	4,03	24,15
RGT= 32/90	-5	23	1158,9	3958	997,4	1,91	6,52	1,64	607,5	4,09	26,02
liquid temp	0	32	1421,7	4855	1223,5	2,17	7,40	1,86	656,3	4,27	32,21
Tliq= 45/113	7,2	45	1873,7	6399	1612,5	2,57	8,78	2,21	728,5	4,53	43,12
[°C / °F]	-20	-4	461,2	1575	396,9	0,95	3,25	0,82	485,3	3,65	11,38
cond. pressure	-15	5	597,5	2041	514,2	1,09	3,74	0,94	545,8	3,87	14,84
pc= 55/131	-10	14	758,4	2590	652,7	1,25	4,28	1,08	605,2	4,08	18,97
return gas temp	-7	20	879,6	3004	757,0	1,37	4,66	1,18	644,0	4,22	22,12
RGT= 32/90	-5	23	947,2	3235	815,1	1,43	4,87	1,23	663,9	4,30	23,89
liquid temp	0	32	1167,3	3986	1004,6	1,62	5,52	1,39	722,2	4,51	29,74
Tliq= 55/131	7,2	45	1546,2	5280	1330,7	1,92	6,55	1,65	806,1	4,81	40,09



# SC Compressors

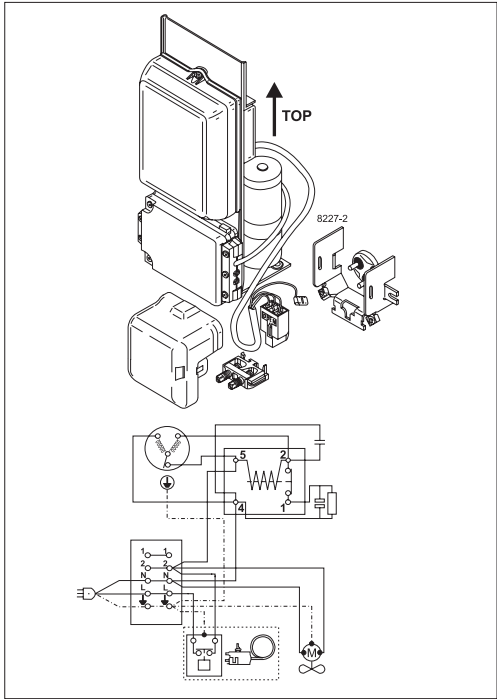
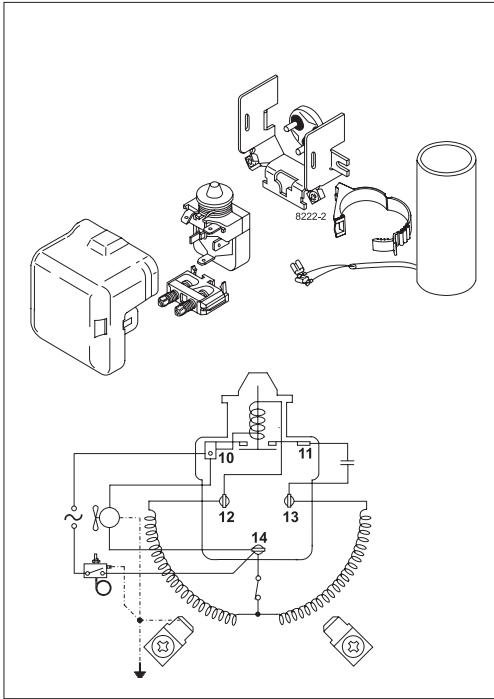



# SC Compressors

## Service/Repair – R290



8545



Secop accepts no responsibility for possible errors in catalogs, brochures, and other printed material. Secop reserves the right to alter its products without notice. This also applies to products already on order provided that such alterations can be made without subsequent changes being necessary to specifications already agreed. All trademarks in this material are the property of the respective companies. Secop and the Secop logotype are trademarks of Secop GmbH. All rights reserved. [www.secop.com](http://www.secop.com)