

Single Pack SC15MLX 220-240V 50Hz CSIR

Codice Imballo Singolo: **195B4052**

Posizione	Titolo	Codice	Quantità
1	Compressor SC15MLX	104L2869	1
2	Starting relay	117U6013	1
3	Starting capacitor (125 μ F 220V, 6.3mm)	117U5012	1
4	Cord relief	103N1004	1
5	Cover	103N2009	1
6	Bolt joint for one compressor M6 \varnothing 16mm	118-1917	1

Secop GmbH • Lise-Meitner-Straße 29 • 24941 Flensburg, Germany • Tel: +49 46149410 • www.secop.com

Secop non si assume alcuna responsabilità per eventuali errori presenti in cataloghi, brochure e altro materiale stampato. Secop si riserva il diritto di modificare i propri prodotti senza preavviso. Ciò vale anche per i prodotti già ordinati, a condizione che tali modifiche possano essere apportate senza che siano necessarie modifiche successive alle specifiche già concordate. Tutti i marchi presenti in questo materiale sono di proprietà delle rispettive aziende. Secop e il logo Secop sono marchi di Secop GmbH. Tutti i diritti sono riservati.

Model

Designation	SC15MLX	220-240V/50Hz 1~	Sales code:	104L2869
-------------	----------------	------------------	-------------	-----------------

Compressor design

Oil type	Polyolester	Refrigerant(s)	R404A, R452A, R507
Oil viscosity	32cST	Displacement	15,28cm ³ / 0,93cu.in
Oil quantity	550cm ³ / 18,6fl.oz	Compressors on pallet	80
Refr. charge - tech. limit	1300g / 45,9oz		
Free gas volume comp.	1460cm ³ / 49,4fl.oz		
Weight	13,8kg / 30,4lbs		
Motor protection	1# internal		
Winding resistance main	3,3Ω (at 25°C)		
Winding resistance aux	16,5Ω (at 25°C)		
Max. winding temp.	125°C / 257°F		
Max. discharge temp.	130°C / 266°F		



General - Configurations with SC15MLX

	Conf. 1	Conf. 2	Conf. 3	Conf. 4
Motorconfiguration	CSIR	CSIR	CSIR	CSIR
Power supply (nominal)	220-240V/50Hz	220-240V/50Hz	220-240V/50Hz	220-240V/50Hz
Number of phases	1	1	1	1
Voltage range	198-254V	198-254V	198-254V	198-254V
Approvals	VDE, CCC, EAC	VDE, CCC, EAC	VDE, CCC, EAC	VDE, CCC, EAC
Starting torque	HST	HST	HST	HST
Note	- / -	- / -	- / -	- / -

Applications with SC15MLX

	Conf. 1	Conf. 2	Conf. 3	Conf. 4
Refrigerant	R404A	R452A	R448A	R449A
Application	MBP	MBP	MBP	MBP
System cooling	fan 3m/s	fan 3m/s	fan 3m/s	fan 3m/s
Hot gas defrost	OK	OK	OK	OK
Long interval pull down	OK	OK	OK	OK

Electrical data - Configurations with SC15MLX

	Conf. 1	Conf. 2	Conf. 3	Conf. 4
Starting device type	relay	relay	relay	relay
Run capacitor	- / -	- / -	- / -	- / -
Start capacitor	125μF	125μF	125μF	125μF
LRA (locked rotor amps / 4s)	23,5A	23,5A	23,5A	23,5A
RLA (rated load amps / 1s)	4,5A	4,5A	4,5A	4,5A
Cut in current	23,5A	23,5A	23,5A	23,5A

Model

Designation

SC15MLX

220-240V/50Hz 1~

Sales code:

104L2869

Compressor dimensions

Housing	A Height	219mm / 8,62in
	B Height	213mm / 8,39in
	C Length shell	218mm / 8,58in
	D Length w. cover	255mm / 10,04in
	E Width	151mm / 5,94in

Connectors	Suction X	Discharge Y	Process Z
Diameter [mm]	øi 10,11-10,29	øi 6,11-6,29	øi 6,11-6,29
(i:inside, o:outside) [in]	øi 0,4-0,41	øi 0,24-0,25	øi 0,24-0,25
Material	copper	copper	copper
Horizontal angle ±2°	37°	37°	143°
Vertical angle ±2°	30°	0°	150°
Position l/h/w [mm]	107/193/55	115/110/63	-107/193/55
[in]	4,2/7,6/2,2	4,5/4,3/2,5	-4,2/7,6/2,2
Straight tube l. [mm]	12	12	12
[in]	0,5	0,5	0,5



Compressor fixation



Bolt joint



Snap-on



Mounting accessories

Mounting accessories	one comp.	multi pack
Bolt joint M6 ø16mm	118-1917	118-1918
Bolt joint ø1/4" ø16mm	118-1946	
Bolt joint ø1/4" ø19mm	118-1949	
Snap-on ø7,3 ø16mm	118-1947	118-1919

Application notes

Provision for PE Grounding is located at the PE Stamp on the compressor

Model

Designation	SC15MLX	220-240V/50Hz	Conf. 1	Sales code:	104L2869
-------------	----------------	----------------------	----------------	-------------	-----------------

Configuration

Motorconfiguration	CSIR
Power supply (nominal)	220-240V/50Hz 1~
Refrigerant	R404A
Application	MBP
Voltage range	198-254V
Starting torque	HST
Approvals	VDE CCC EAC

Electrical accessories / wiring diagram



Ambient/ machine room temperatures minimum /maximum

Ambient temperature range:	10 - 43°C / 50 - 110°F
Machine room temperature range:	10 - 48°C / 50 - 119°F
Compressor cooling:	fan 3m/s

Operation Limits

Operation pressure range

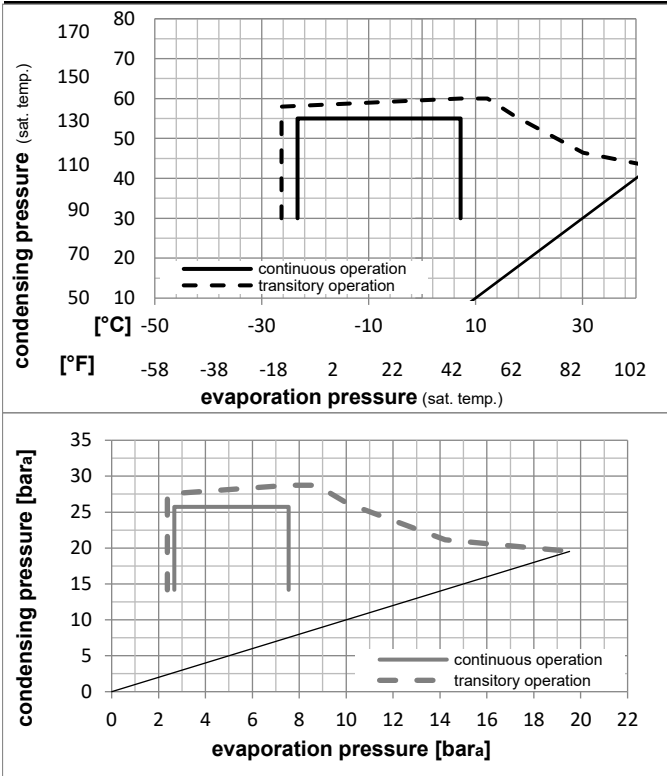

Components

a2	relay	117U6013
c	start capacitor (125µF)	117U5012
d	cord relief	103N1004
b	plastic cover	103N2009

Model

Designation **SC15MLX** **220-240V/50Hz** Conf. 1 Sales code: **104L2869**

Optimization + standard conditions

R404A, 220V/50Hz, CSIR, fan 3m/s, VDE, CCC, EAC

		Evaporating pressure (saturation temperature)				Condensing pressure (saturation temperature)			Return gas temp.			Liquid temp.			Cooling capacity			COP	EER	Power consumption			
		pe	pc	RGT	Tliq	[W]	[Btu/h]	[kcal/h]	[W/W]	[Btu/Wh]	[kcal/Wh]	P1	I	m	[W]	[A]	[kg/h]						
[°C]	[°F]																						
-7	20	54	130	35	95	46	115	1376,9	4702	1184,9	1,56	5,31	1,34	885,2	5,17	37,88					ASHRAE MBP		
-10	14	55	131	32	90	55	131	1024,6	3499	881,7	1,22	4,17	1,05	839,4	4,96	32,80					cecomaf MBP		
-10	14	45	113	20	68	45	113	1210,5	4134	1041,8	1,55	5,30	1,34	780,1	4,73	36,46					EN12900 MBP		
-7	20	49	120	18	65	49	120	1259,4	4301	1083,8	1,49	5,09	1,28	844,4	5,01	41,15					ARI540 MBP		
-10	14	45	113	32	90	45	113	1284,7	4388	1105,7	1,65	5,62	1,42	780,1	4,73	35,38					opt		
-25	-13	45	113	32	90	45	113	654,5	2235	563,3	1,11	3,77	0,95	592,3	3,93	17,66					opt		

Performance tables

R404A, 220V/50Hz, CSIR, fan 3m/s, VDE, CCC, EAC

	pe		Cooling capacity			COP	EER	P1	I	m	
	[°C]	[°F]	[W]	[Btu/h]	[kcal/h]	[W/W]	[Btu/Wh]	[kcal/Wh]	[W]	[A]	[kg/h]
[°C / °F]	-23	-10	710,1	2425	611,1	1,16	3,95	1,00	613,4	4,01	19,19
cond. pressure	-20	-4	828,7	2830	713,2	1,27	4,32	1,09	654,4	4,18	22,48
pc= 45/113	-15	5	1037,5	3543	892,9	1,45	4,94	1,25	716,9	4,44	28,34
return gas temp.	-10	14	1284,7	4388	1105,7	1,65	5,62	1,42	780,1	4,73	35,38
RGT= 32/90	-5	23	1573,9	5375	1354,5	1,86	6,36	1,60	844,6	5,03	43,76
liquid temp	0	32	1908,7	6519	1642,7	2,10	7,16	1,80	910,8	5,34	53,66
Tliq= 45/113	7,2	45	2478,3	8464	2132,8	2,45	8,38	2,11	1010,3	5,83	71,07
[°C / °F]	-23	-10	564,3	1927	485,7	0,88	3,01	0,76	639,5	4,14	17,68
cond. pressure	-20	-4	657,9	2247	566,2	0,95	3,26	0,82	689,2	4,33	20,70
pc= 55/131	-15	5	824,6	2816	709,7	1,08	3,69	0,93	764,2	4,63	26,15
return gas temp	-10	14	1024,6	3499	881,7	1,22	4,17	1,05	839,4	4,96	32,80
RGT= 32/90	-5	23	1261,3	4308	1085,5	1,38	4,71	1,19	915,4	5,30	40,83
liquid temp	0	32	1538,5	5254	1324,1	1,55	5,29	1,33	992,5	5,66	50,45
Tliq= 55/131	7,2	45	2016,1	6885	1735,1	1,82	6,22	1,57	1106,7	6,20	67,66

Model

Designation	SC15MLX	220-240V/50Hz	Conf. 2	Sales code:	104L2869
-------------	----------------	----------------------	----------------	-------------	-----------------

Configuration

Motorconfiguration	CSIR
Power supply (nominal)	220-240V/50Hz 1~
Refrigerant	R452A
Application	MBP
Voltage range	198-254V
Starting torque	HST
Approvals	VDE CCC EAC

Electrical accessories / wiring diagram

CSIR

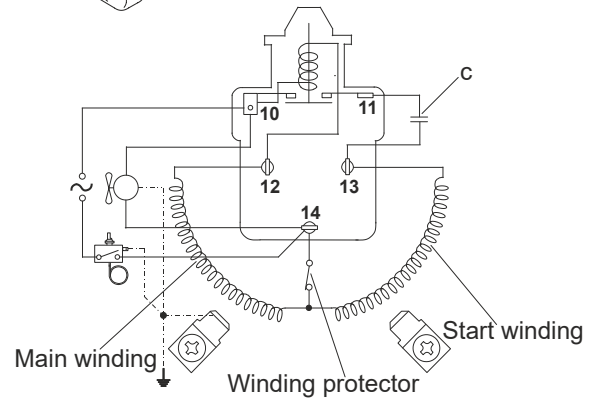
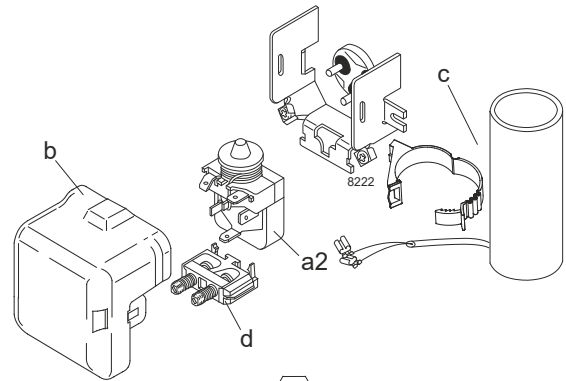

Ambient/ machine room temperatures minimum /maximum

Ambient temperature range:	10 - 43°C / 50 - 110°F
Machine room temperature range:	10 - 48°C / 50 - 119°F
Compressor cooling:	fan 3m/s

Operation Limits

Operation pressure range

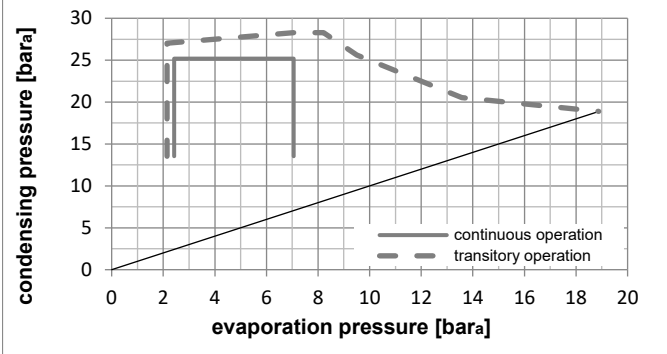
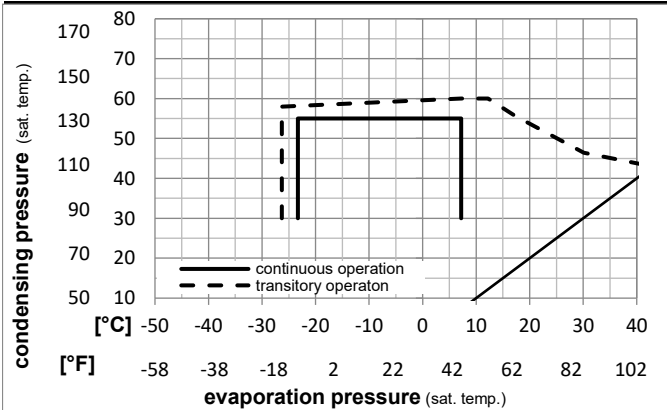

Components

a2	relay	117U6013
c	start capacitor (125µF)	117U5012
d	cord relief	103N1004
b	plastic cover	103N2009

Model

Designation **SC15MLX** **220-240V/50Hz** Conf. 2 Sales code: **104L2869**

Optimization + standard conditions

R452A, 220V/50Hz, CSIR, fan 3m/s, VDE, CCC, EAC

		Evaporating pressure (saturation temperature)				Condensing pressure (saturation temperature)			Return gas temp.			Liquid temp.			Cooling capacity			COP	EER	Power consumption			
		pe	pc	RGT	Tliq	[W]	[Btu/h]	[kcal/h]	[W/W]	[Btu/Wh]	[kcal/Wh]	P1	I	m	[W]	[A]	[kg/h]						
[°C]	[°F]																						
-7	20	54	130	35	95	46	115	1301,3	4444	1119,9	1,54	5,26	1,33	844,6	5,00	36,61	ASHRAE MBP						
-10	14	55	131	32	90	55	131	970,1	3313	834,8	1,22	4,15	1,05	797,4	4,79	31,53	cecomaf MBP						
-10	14	45	113	20	68	45	113	1142,2	3901	983,0	1,54	5,26	1,33	741,5	4,55	35,10	EN12900 MBP						
-7	20	49	120	18	65	49	120	1196,3	4086	1029,5	1,48	5,07	1,28	805,9	4,83	39,69	ARI540 MBP						
-10	14	45	113	32	90	45	113	1210,4	4134	1041,7	1,63	5,57	1,40	741,5	4,55	34,10	opt						
-25	-13	45	113	32	90	45	113	602,5	2058	518,5	1,09	3,72	0,94	552,5	3,74	16,67	opt						

Performance tables

R452A, 220V/50Hz, CSIR, fan 3m/s, VDE, CCC, EAC

	pe		Cooling capacity			COP	EER	P1	I	m	
	[°C]	[°F]	[W]	[Btu/h]	[kcal/h]	[W/W]	[Btu/Wh]	[kcal/Wh]	[W]	[A]	[kg/h]
[°C / °F]	-23	-10	655,8	2240	564,4	1,14	3,90	0,98	573,6	3,83	18,17
cond. pressure	-20	-4	769,7	2629	662,4	1,25	4,28	1,08	614,7	4,01	21,40
pc= 45/113	-15	5	971,1	3316	835,7	1,43	4,90	1,23	677,5	4,28	27,16
return gas temp.	-10	14	1210,4	4134	1041,7	1,63	5,57	1,40	741,5	4,55	34,10
RGT= 32/90	-5	23	1491,6	5094	1283,6	1,85	6,31	1,59	807,3	4,84	42,38
liquid temp	0	32	1818,5	6210	1565,0	2,08	7,10	1,79	875,2	5,13	52,19
Tliq= 45/113	7,2	45	2377,4	8119	2046,0	2,43	8,30	2,09	978,1	5,57	69,45
[°C / °F]	-23	-10	521,6	1781	448,9	0,88	2,99	0,75	595,5	3,92	16,63
cond. pressure	-20	-4	612,4	2092	527,1	0,95	3,24	0,82	645,3	4,14	19,60
pc= 55/131	-15	5	774,7	2646	666,7	1,07	3,67	0,92	721,0	4,46	24,97
return gas temp	-10	14	970,1	3313	834,8	1,22	4,15	1,05	797,4	4,79	31,53
RGT= 32/90	-5	23	1202,5	4107	1034,8	1,37	4,69	1,18	875,0	5,13	39,47
liquid temp	0	32	1475,8	5040	1270,1	1,55	5,28	1,33	954,3	5,47	49,00
Tliq= 55/131	7,2	45	1949,0	6656	1677,3	1,82	6,21	1,56	1072,6	5,98	66,05

Model

Designation	SC15MLX	220-240V/50Hz	Conf. 3	Sales code:	104L2869
-------------	----------------	----------------------	----------------	-------------	-----------------

Configuration

Motorconfiguration	CSIR
Power supply (nominal)	220-240V/50Hz 1~
Refrigerant	R448A
Application	MBP
Voltage range	198-254V
Starting torque	HST
Approvals	

Electrical accessories / wiring diagram

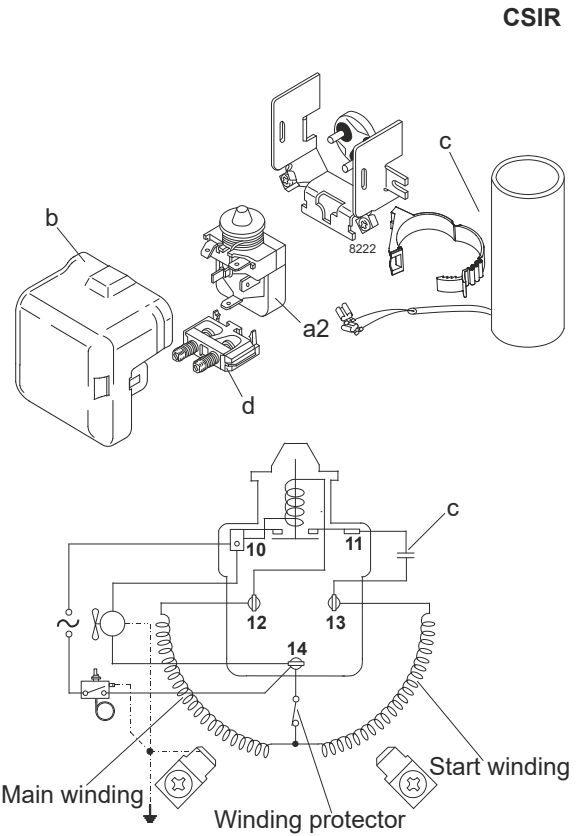

Ambient/ machine room temperatures minimum /maximum

Ambient temperature range:	10 - 38°C / 50 - 101°F
Machine room temperature range:	10 - 43°C / 50 - 110°F
Compressor cooling:	fan 3m/s

Operation Limits

Operation pressure range

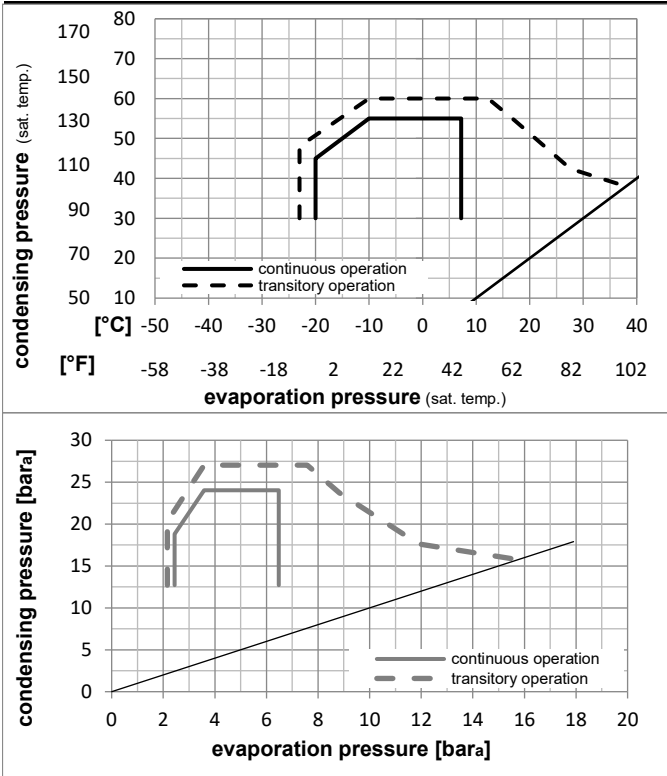

Components

a2	relay	117U6013
c	start capacitor (125µF)	117U5012
d	cord relief	103N1004
b	plastic cover	103N2009

Model

Designation **SC15MLX** **220-240V/50Hz** Conf. 3 Sales code: **104L2869**

Optimization + standard conditions

R448A, 220V/50Hz, CSIR, fan 3m/s,

	Evaporating pressure (saturation temperature)				Cooling capacity			COP	EER	P1	Power consumption			ASHRAE MBP				
	pe	pc	RGT	Tliq	[W]	[Btu/h]	[kcal/h]				l	Ref. mass flow						
	[°C]	[°F]	[°C]	[°F]	[W]	[Btu/h]	[kcal/h]	[W/W]	[Btu/Wh]	[kcal/Wh]	[W]	[A]	[kg/h]					
	-7	20	54	130	35	95	46	115	1255,1	4286	1080,1	1,57	5,38	1,36	797,1	4,79	27,41	ASHRAE MBP
	-10	14	55	131	32	90	55	131	958,9	3275	825,2	1,28	4,36	1,10	750,4	4,59	23,48	cecomaf MBP
	-10	14	45	113	20	68	45	113	1116,9	3814	961,2	1,60	5,46	1,37	699,1	4,37	26,13	EN12900 MBP
	-7	20	49	120	18	65	49	120	1193,6	4076	1027,2	1,57	5,35	1,35	761,5	4,64	29,69	ARI540 MBP
	-10	14	45	113	32	90	45	113	1162,2	3969	1000,2	1,66	5,68	1,43	699,1	4,37	25,40	opt
	-25	-13	45	113	32	90	45	113	562,0	1919	483,7	1,10	3,75	0,95	511,4	3,56	12,09	opt

Performance tables

R448A, 220V/50Hz, CSIR, fan 3m/s,

	pe		Cooling capacity			COP	EER	P1	l	m	
	[°C]	[°F]	[W]	[Btu/h]	[kcal/h]						
[°C / °F]	-20	-4	725,6	2478	624,5	1,27	4,32	1,09	573,5	3,83	15,67
cond. pressure	-15	5	924,2	3156	795,4	1,45	4,96	1,25	635,9	4,10	20,07
pc= 45/113	-10	14	1162,2	3969	1000,2	1,66	5,68	1,43	699,1	4,37	25,40
return gas temp.	-7	20	1343,1	4587	1155,9	1,81	6,19	1,56	741,6	4,55	29,49
RGT= 32/90	-5	23	1444,2	4932	1242,9	1,89	6,46	1,63	763,8	4,65	31,79
liquid temp	0	32	1774,6	6061	1527,3	2,14	7,30	1,84	830,7	4,94	39,41
Tliq= 45/113	7,2	45	2344,5	8007	2017,7	2,52	8,59	2,17	931,9	5,37	52,88
[°C / °F]	-20	-4	592,4	2023	509,9	0,99	3,37	0,85	601,0	3,95	14,32
cond. pressure	-15	5	757,9	2588	652,2	1,12	3,83	0,97	675,4	4,27	18,43
pc= 55/131	-10	14	958,9	3275	825,2	1,28	4,36	1,10	750,4	4,59	23,48
return gas temp	-7	20	1113,2	3802	958,0	1,39	4,75	1,20	800,6	4,81	27,41
RGT= 32/90	-5	23	1199,9	4098	1032,6	1,45	4,96	1,25	826,7	4,92	29,63
liquid temp	0	32	1485,4	5073	1278,3	1,64	5,61	1,41	904,9	5,26	37,05
Tliq= 55/131	7,2	45	1983,8	6775	1707,3	1,94	6,63	1,67	1022,1	5,76	50,35

Model

Designation	SC15MLX	220-240V/50Hz	Conf. 4	Sales code:	104L2869
-------------	----------------	----------------------	----------------	-------------	-----------------

Configuration

Motorconfiguration	CSIR
Power supply (nominal)	220-240V/50Hz 1~
Refrigerant	R449A
Application	MBP
Voltage range	198-254V
Starting torque	HST
Approvals	

Electrical accessories / wiring diagram

CSIR

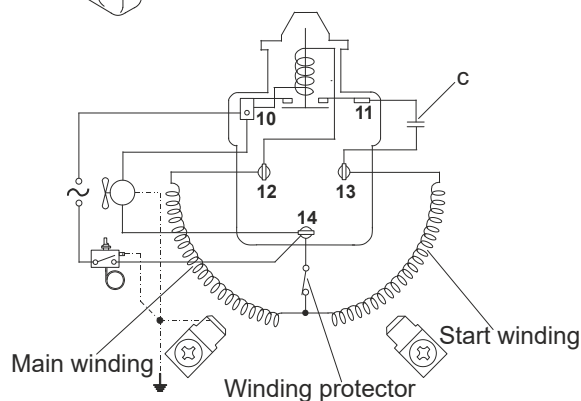
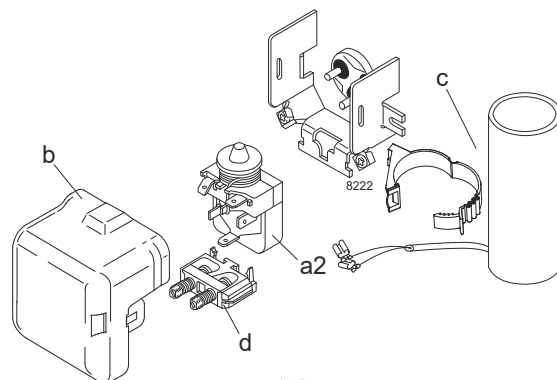

Ambient/ machine room temperatures minimum /maximum

Ambient temperature range: 10 - 38°C / 50 - 101°F

Machine room temperature range: 10 - 43°C / 50 - 110°F

Compressor cooling: fan 3m/s

Operation Limits

Operation pressure range

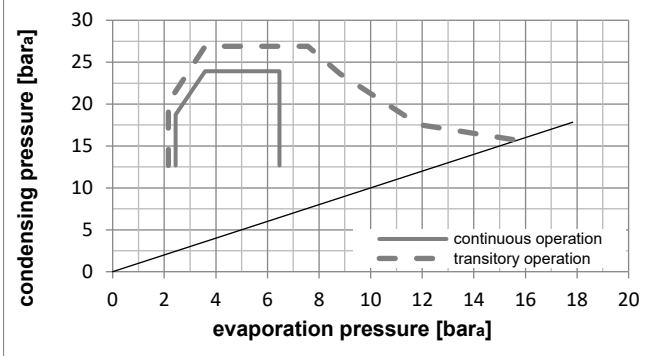
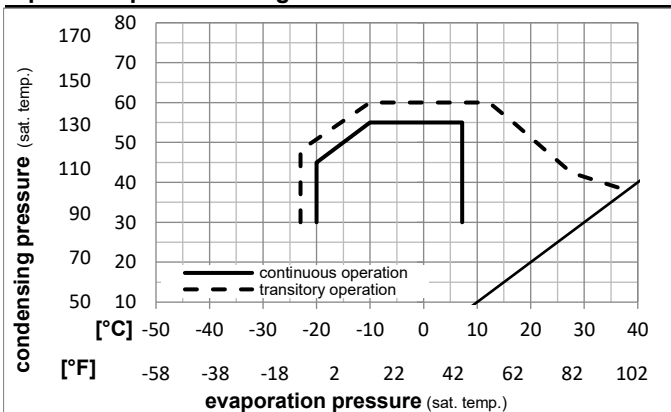

Components

a2	relay	117U6013
c	start capacitor (125μF)	117U5012
d	cord relief	103N1004
b	plastic cover	103N2009

Model

Designation **SC15MLX** **220-240V/50Hz** Conf. 4 Sales code: **104L2869**

Optimization + standard conditions

R449A, 220V/50Hz, CSIR, fan 3m/s,

		Evaporating pressure (saturation temperature)				Condensing pressure (saturation temperature)						Power consumption			
		Return gas temp.				Liquid temp.						Current consumption			Ref. mass flow
		Cooling capacity				COP	EER	P1			I	m			
		pe	pc	RGT	Tliq	[W]	[Btu/h]	[kcal/h]	[W/W]	[Btu/Wh]	[kcal/Wh]	[W]	[A]	[kg/h]	
[°C]	-7	54	35	46	1248,5	4264	1074,5	1,57	5,38	1,36	792,8	4,77	27,81	ASHRAE MBP	
[°F]	20	130	95	115											
[°C]	-10	55	32	55	952,6	3253	819,8	1,28	4,36	1,10	746,7	4,58	23,83	cecomaf MBP	
[°F]	14	131	90	131											
[°C]	-10	45	20	45	1109,7	3790	955,0	1,59	5,44	1,37	696,1	4,36	26,50	EN12900 MBP	
[°F]	14	113	68	113											
[°C]	-7	49	18	49	1184,8	4046	1019,6	1,56	5,34	1,35	757,7	4,62	30,11	ARI540 MBP	
[°F]	20	120	65	120											
[°C]	-10	45	32	45	1155,9	3948	994,8	1,66	5,67	1,43	696,1	4,36	25,76	opt	
[°F]	14	113	90	113											
[°C]	-25	45	32	45	559,8	1912	481,8	1,10	3,75	0,94	510,0	3,56	12,27	opt	
[°F]	-13	113	90	113											

Performance tables

R449A, 220V/50Hz, CSIR, fan 3m/s,

	pe		Cooling capacity			COP	EER	P1			I	m
	[°C]	[°F]	[W]	[Btu/h]	[kcal/h]	[W/W]	[Btu/Wh]	[kcal/Wh]	[W]	[A]	[kg/h]	
[°C / °F]	-20	-4	722,4	2467	621,7	1,26	4,32	1,09	571,6	3,82	15,91	
cond. pressure	-15	5	919,6	3140	791,4	1,45	4,96	1,25	633,5	4,09	20,36	
pc= 45/113	-10	14	1155,9	3948	994,8	1,66	5,67	1,43	696,1	4,36	25,76	
return gas temp.	-7	20	1335,6	4561	1149,4	1,81	6,18	1,56	738,2	4,54	29,91	
RGT= 32/90	-5	23	1436,0	4904	1235,8	1,89	6,45	1,63	760,1	4,63	32,24	
liquid temp	0	32	1764,1	6025	1518,2	2,14	7,29	1,84	826,1	4,92	39,96	
Tliq= 45/113	7,2	45	2330,1	7958	2005,4	2,52	8,60	2,17	925,9	5,35	53,62	
[°C / °F]	-20	-4	589,2	2012	507,1	0,98	3,36	0,85	599,0	3,94	14,54	
cond. pressure	-15	5	753,3	2573	648,3	1,12	3,82	0,96	672,6	4,26	18,71	
pc= 55/131	-10	14	952,6	3253	819,8	1,28	4,36	1,10	746,7	4,58	23,83	
return gas temp	-7	20	1105,7	3776	951,6	1,39	4,74	1,20	796,2	4,79	27,80	
RGT= 32/90	-5	23	1191,7	4070	1025,6	1,45	4,95	1,25	822,0	4,90	30,06	
liquid temp	0	32	1475,0	5037	1269,4	1,64	5,60	1,41	899,0	5,23	37,58	
Tliq= 55/131	7,2	45	1969,6	6727	1695,1	1,94	6,63	1,67	1014,1	5,72	51,07	



SC Compressors





SC Compressors

Service/Repair – R290



8545



Secop accepts no responsibility for possible errors in catalogs, brochures, and other printed material. Secop reserves the right to alter its products without notice. This also applies to products already on order provided that such alterations can be made without subsequent changes being necessary to specifications already agreed. All trademarks in this material are the property of the respective companies. Secop and the Secop logotype are trademarks of Secop GmbH. All rights reserved. www.secop.com