

Single Pack NF7CLX 115-127V 60Hz CSIR

Codice Imballo Singolo: **195B4075**

Posizione	Titolo	Codice	Quantità
1	Compressor NF7CLX	105F1721	1
2	Starting relay (overload protector MRT22AFZ-6)	117U4129	1
3	Starting capacitor (320 μ F 125V, 6.3mm)	117U5022	1
4	Cord relief	117U0349	2
5	Cover	117U1021	1
6	Bolt joint for one compressor M6 \varnothing 16mm	118-1917	1

Secop GmbH • Lise-Meitner-Straße 29 • 24941 Flensburg, Germany • Tel: +49 46149410 • www.secop.com

Secop non si assume alcuna responsabilità per eventuali errori presenti in cataloghi, brochure e altro materiale stampato. Secop si riserva il diritto di modificare i propri prodotti senza preavviso. Ciò vale anche per i prodotti già ordinati, a condizione che tali modifiche possano essere apportate senza che siano necessarie modifiche successive alle specifiche già concordate. Tutti i marchi presenti in questo materiale sono di proprietà delle rispettive aziende. Secop e il logo Secop sono marchi di Secop GmbH. Tutti i diritti sono riservati.

Model

Designation	NF7CLX	115-127V/60Hz 1~	Sales code:	105F1721
-------------	---------------	-------------------------	-------------	-----------------

Compressor design

Oil type	Polyolester	Refrigerant(s)	R404A, R452A, R507
Oil viscosity	32cST	Displacement	7,27cm ³ / 0,44cu.in
Oil quantity	300cm ³ / 10,1fl.oz	Compressors on pallet	80
Refr. charge - tech. limit	400g / 14,1oz		
Free gas volume comp.	2280cm ³ / 77,1fl.oz		
Weight	10kg / 22lbs		
Motor protection	external		
Winding resistance main	1,62Ω (at 25°C)		
Winding resistance aux	4,9Ω (at 25°C)		
Max. winding temp.	125°C / 257°F		
Max. discharge temp.	130°C / 266°F		



General - Configurations with NF7CLX

	Conf. 1	Conf. 2
Motorconfiguration	CSIR	CSIR
Power supply (nominal)	115V/60Hz	115V/60Hz
Number of phases	1	1
Voltage range	95-135V	95-135V
Approvals	UL, CCC, EAC	UL, CCC, EAC
Starting torque	HST	HST
Note	- / -	

Applications with NF7CLX

	Conf. 1	Conf. 2
Refrigerant	R404A	R452A
Application	LBP+MBP	LBP+MBP
System cooling	fan 3m/s	fan 3m/s
Hot gas defrost	- / -	- / -
Long interval pull down	OK	OK

Electrical data - Configurations with NF7CLX

	Conf. 1	Conf. 2
Starting device type	relay	relay
Run capacitor	- / -	- / -
Start capacitor	320μF	320μF
LRA (locked rotor amps / 4s)	30,8A	30,8A
RLA (rated load amps / 1s)	4,9A	4,9A
Cut in current	30,8A	30,8A
IP class	21	21

Model

Designation	NF7CLX	115-127V/60Hz 1~	Sales code:	105F1721
-------------	---------------	-------------------------	-------------	-----------------

Compressor dimensions

Housing	A Height	203mm / 7,99in
	B Height	197mm / 7,76in
	C Length shell	205mm / 8,07in
	D Length w. cover	254mm / 10in
	E Width	166mm / 6,54in

Connectors		Suction	Discharge	Process
		X	Y	Z
Diameter	[mm]	øi 8,11-8,29	øi 6,41-6,59	øi 6,41-6,59
(i:inside, o:outside)	[in]	øi 0,32-0,33	øi 0,25-0,26	øi 0,25-0,26
Material		copper	copper	copper
Horizontal angle	±2°	0°	0°	0°
Vertical angle	±2°	15°	35°	155°
Position l/h/w	[mm]	126/76/78	133/103/54	-107/94/72
	[in]	4,9/3/3,1	5,2/4/2,1	-4,2/3,7/2,8
Straight tube l.	[mm]	12	12	12
	[in]	0,5	0,5	0,5

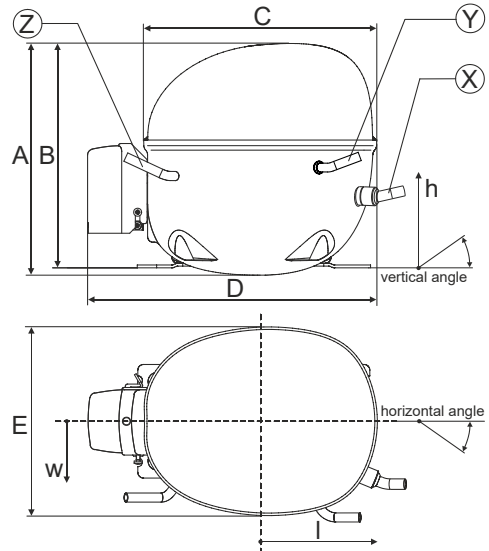

Compressor fixation

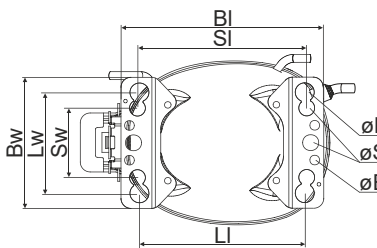

Baseplate	[mm]	[inch]
BI	204	8.03
BW	132	5.2
øE	ø 9.7	ø 0.38
Large holes	[mm]	[inch]
LI	165	6.5
LW	101.6	4
øL	ø 19	ø 0.75
Small holes	[mm]	[inch]
SI	170	6.7
SW	70	2.76
øS	ø 16	ø 0.63

Bolt joint



Snap-on

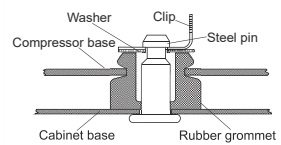

Mounting accessories	one comp.	multi pack
Bolt joint M6 ø16mm	118-1917	118-1918
Bolt joint ø1/4" ø16mm	118-1946	
Bolt joint ø1/4" ø19mm	118-1949	
Snap-on ø7,3 ø16mm	118-1947	118-1919

Application notes

LRA value on compressor label and datasheet may differ due to different test conditions for UL approval.

Model

Designation	NF7CLX	115V/60Hz	Conf. 1	Sales code:	105F1721
-------------	---------------	------------------	----------------	-------------	-----------------

Configuration

Motorconfiguration	CSIR
Power supply (nominal)	115V/60Hz 1~
Refrigerant	R404A
Application	LBP+MBP
Voltage range	95-135V
Starting torque	HST
Approvals	UL CCC EAC

Electrical accessories / wiring diagram

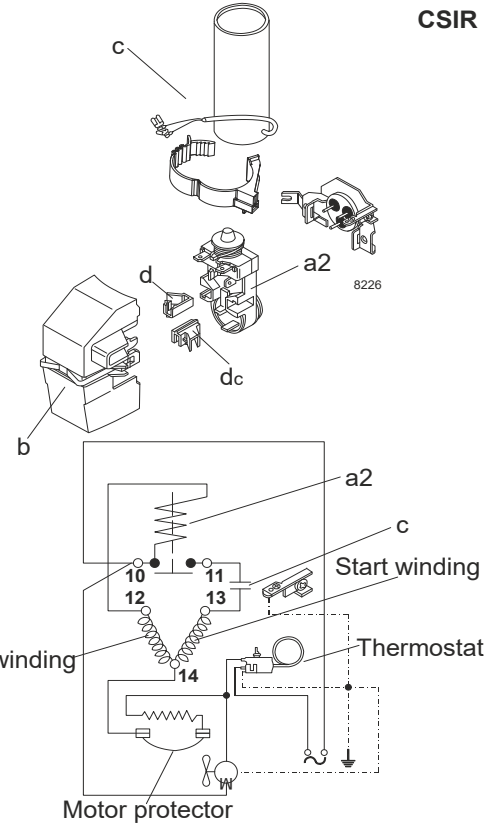

Ambient temperatures / system cooling

Ambient temperature min.:	10°C / 50°F
Ambient temperature max.:	43°C / 110°F

System cooling (n/a: outside limits)			
T ambient	LBP	MBP	HBP
32°C / 90°F	fan 3m/s	fan 3m/s	n/a
38°C / 100°F	fan 3m/s	fan 3m/s	n/a
43°C / 110°F	fan 3m/s	fan 3m/s	n/a

Operation pressure range

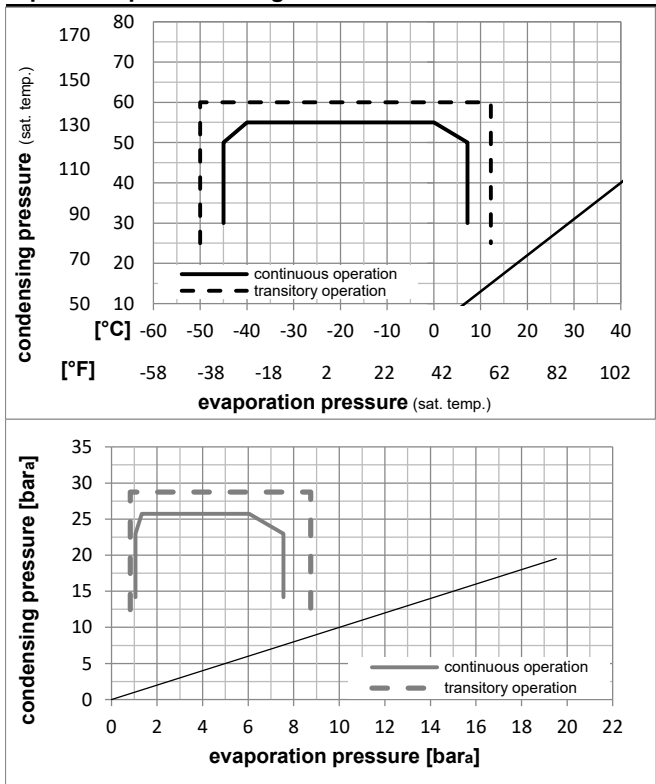

Components

a2	current relay (MRT22AFZ-6)	117U4129
c	start capacitor (320µF)	117U5022
b	plastic cover	117U1021
d/dc	cord relief	117U0349
d/dc	cord relief	117U0349

Model

Designation **NF7CLX 115V/60Hz** Conf. 1 Sales code: **105F1721**

Optimization + standard conditions

115V/60Hz, CSIR, fan 3m/s, UL, CCC, EAC

Evaporating pressure (saturation temperature)				Condensing pressure (saturation temperature)				Power consumption				ASHRAE LBP		
Return gas temp.				Liquid temp.				Current consumption					Ref. mass flow	
Cooling capacity				COP	EER	P1	I	m						
pe	pc	RGT	Tliq	[W]	[Btu/h]	[kcal/h]	[W/W]	[Btu/Wh]	[kcal/Wh]	[W]	[A]		[kg/h]	
[°C]	-23,3	54,4	32,2	32,2	451,3	1541	388,4	1,23	4,19	1,06	367,7	4,53	10,52	ASHRAE LBP
[°F]	-10	130	90	90										
[°C]	-25	55	32	55	305,5	1043	262,9	0,87	2,95	0,74	353,1	4,44	9,55	cecomaf LBP
[°F]	-13	131	89,6	131										
[°C]	-35	40	20	40	248,1	847	213,5	0,93	3,19	0,80	266,0	3,90	6,74	EN12900 LBP
[°F]	-31	104	68	104										
[°C]	-23,3	48,9	4,44	48,9	340,3	1162	292,9	0,94	3,20	0,81	362,8	4,46	12,05	ARI540 LBP
[°F]	-10	120	40	120										
[°C]	-23,3	40,6	32,2	32,2	512,7	1751	441,2	1,46	4,98	1,26	351,5	4,37	11,95	AHAM LBP
[°F]	-10	105	90	90										
[°C]	-35	45	32	45	230,4	787	198,3	0,86	2,95	0,74	267,1	3,91	6,16	opt
[°F]	-31	113	89,6	113										

Performance tables

115V/60Hz, CSIR, fan 3m/s, UL, CCC, EAC

	pe	Cooling capacity			COP	EER	P1	I	m		
	[°C]	[°F]	[W]	[Btu/h]	[kcal/h]	[W/W]	[Btu/Wh]	[kcal/Wh]	[W]	[A]	[kg/h]
[°C / °F]	-45	-49	111,0	379	95,5	0,59	2,00	0,50	189,4	3,64	2,95
cond. pressure	-34,4	-30	238,3	814	205,1	0,88	3,00	0,76	271,4	3,93	6,37
pc= 45/113	-23,3	-10	429,9	1468	370,0	1,20	4,10	1,03	358,2	4,42	11,62
return gas temp.	-15	5	623,2	2128	536,4	1,46	4,98	1,25	427,8	4,91	17,02
RGT= 32/90	-3,9	25	961,8	3285	827,7	1,81	6,17	1,56	532,2	5,74	26,80
liquid temp	0	32	1105,1	3774	951,1	1,93	6,59	1,66	572,9	6,07	31,07
Tliq= 45/113	7,2	45	1409,4	4813	1213,0	2,15	7,34	1,85	656,1	6,76	40,42
[°C / °F]	-45	-49	70,3	240	60,5	0,40	1,37	0,34	175,3	3,60	2,16
cond. pressure	-34,4	-30	174,3	595	150,0	0,65	2,21	0,56	269,5	3,96	5,39
pc= 55/131	-23,3	-10	333,3	1138	286,8	0,91	3,09	0,78	368,2	4,53	10,44
return gas temp	-15	5	496,7	1696	427,5	1,11	3,80	0,96	446,0	5,09	15,75
RGT= 32/90	-3,9	25	788,1	2692	678,3	1,41	4,80	1,21	560,4	6,00	25,58
liquid temp	0	32	913,0	3118	785,7	1,51	5,16	1,30	604,5	6,36	29,94
Tliq= 55/131	7,2	45	1180,3	4031	1015,7	1,70	5,81	1,46	693,4	7,09	39,61

Model

Designation	NF7CLX	115V/60Hz	Conf. 2	Sales code:	105F1721
-------------	---------------	------------------	----------------	-------------	-----------------

Configuration

Motorconfiguration	CSIR
Power supply (nominal)	115V/60Hz 1~
Refrigerant	R452A
Application	LBP+MBP
Voltage range	95-135V
Starting torque	HST
Approvals	UL CCC EAC

Electrical accessories / wiring diagram

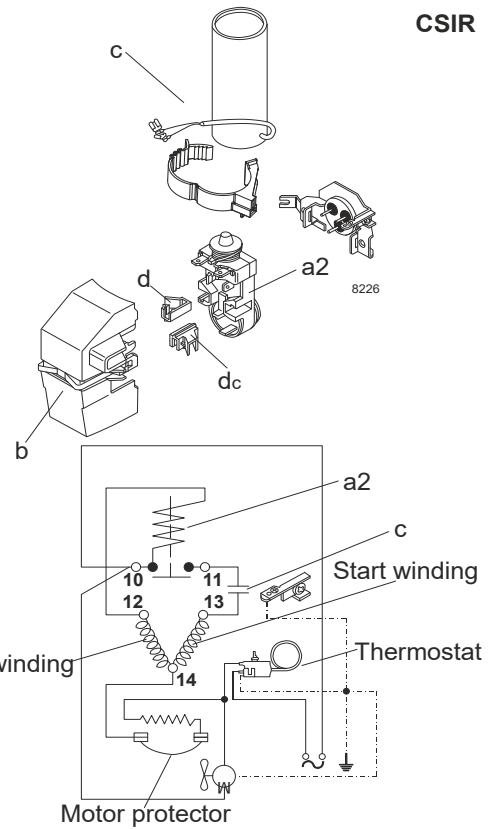

Ambient temperatures / system cooling

Ambient temperature min.:	10°C / 50°F
Ambient temperature max.:	43°C / 110°F

System cooling (n/a: outside limits)			
T ambient	LBP	MBP	HBP
32°C / 90°F	fan 3m/s	fan 3m/s	n/a
38°C / 100°F	fan 3m/s	fan 3m/s	n/a
43°C / 110°F	fan 3m/s	fan 3m/s	n/a

Operation pressure range

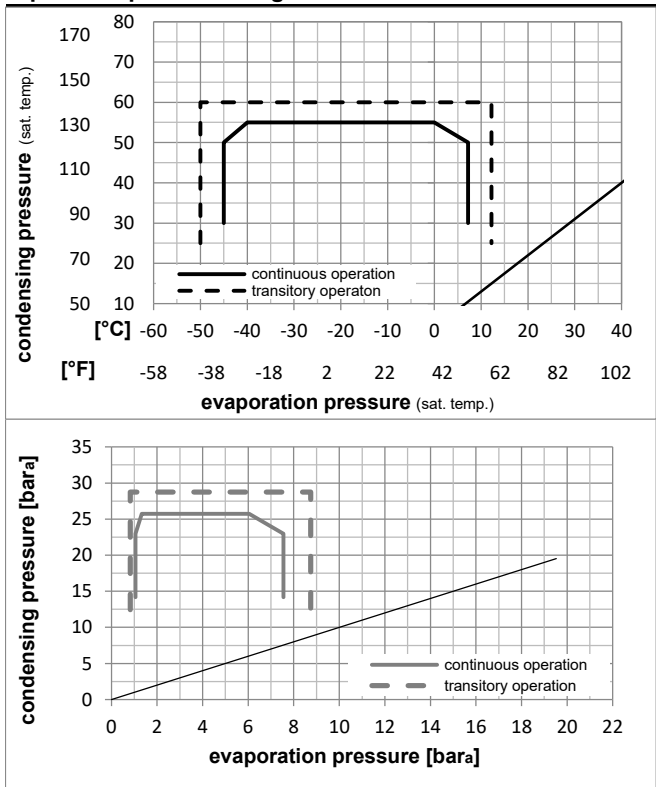

Components

a2	current relay (MRT22AFZ-6)	117U4129
c	start capacitor (320µF)	117U5022
b	plastic cover	117U1021
d/dc	cord relief	117U0349
d/dc	cord relief	117U0349

Model

Designation **NF7CLX 115V/60Hz** Conf. 2 Sales code: **105F1721**

Optimization + standard conditions

115V/60Hz, CSIR, fan 3m/s, UL, CCC, EAC

Evaporating pressure (saturation temperature)		Condensing pressure (saturation temperature)				Cooling capacity			COP	EER	Power consumption			ASHRAE LBP
pe	pc	RGT	Tliq							P1	I	m		
[°C]	[°C]	[°C]	[°C]	[W]	[Btu/h]	[kcal/h]	[W/W]	[Btu/Wh]	[kcal/Wh]	[W]	[A]	[kg/h]		
-23,3	54,4	32,2	32,2	411,9	1407	354,5	1,20	4,10	1,03	342,8	4,44	9,90	ASHRAE LBP	
[°F]														
-10	130	90	90											
-25	55	32	55	281,1	960	241,9	0,86	2,93	0,74	328,1	4,34	8,94	cecomaf LBP	
[°F]														
-13	131	89,6	131											
-35	40	20	40	223,5	763	192,4	0,91	3,11	0,78	245,5	3,77	6,24	EN12900 LBP	
[°F]														
-31	104	68	104											
-23,3	48,9	4,44	48,9	315,8	1078	271,8	0,93	3,18	0,80	339,0	4,42	11,35	ARI540 LBP	
[°F]														
-10	120	40	120											
-23,3	40,6	32,2	32,2	471,4	1610	405,7	1,43	4,89	1,23	329,4	4,35	11,33	AHAM LBP	
[°F]														
-10	105	90	90											
-35	45	32	45	206,8	706	178,0	0,84	2,88	0,73	245,5	3,77	5,68	opt	
[°F]														
-31	113	89,6	113											

Performance tables

115V/60Hz, CSIR, fan 3m/s, UL, CCC, EAC

	pe		Cooling capacity			COP	EER	P1			I	m
	[°C]	[°F]	[W]	[Btu/h]	[kcal/h]	[W/W]	[Btu/Wh]	[kcal/Wh]	[W]	[A]	[kg/h]	
[°C / °F]	-45	-49	94,3	322	81,2	0,56	1,90	0,48	169,1	3,24	2,57	
cond. pressure	-34,4	-30	214,2	732	184,4	0,86	2,93	0,74	249,7	3,80	5,88	
pc= 45/113	-23,3	-10	396,8	1355	341,5	1,18	4,04	1,02	335,2	4,39	10,99	
return gas temp.	-15	5	583,0	1991	501,7	1,44	4,93	1,24	404,2	4,87	16,31	
RGT= 32/90	-3,9	25	912,3	3116	785,1	1,79	6,13	1,54	508,5	5,59	25,98	
liquid temp	0	32	1052,6	3595	905,9	1,92	6,54	1,65	549,6	5,87	30,21	
Tliq= 45/113	7,2	45	1351,9	4617	1163,5	2,13	7,28	1,84	633,8	6,45	39,50	
[°C / °F]	-45	-49	57,4	196	49,4	0,38	1,28	0,32	152,7	3,13	1,80	
cond. pressure	-34,4	-30	155,6	531	133,9	0,63	2,17	0,55	245,4	3,77	4,91	
pc= 55/131	-23,3	-10	307,9	1051	264,9	0,90	3,06	0,77	343,0	4,44	9,81	
return gas temp	-15	5	466,3	1593	401,3	1,11	3,79	0,95	420,6	4,98	15,03	
RGT= 32/90	-3,9	25	752,0	2568	647,2	1,40	4,79	1,21	535,7	5,77	24,74	
liquid temp	0	32	875,3	2989	753,3	1,51	5,15	1,30	580,3	6,08	29,06	
Tliq= 55/131	7,2	45	1140,4	3895	981,4	1,70	5,81	1,46	670,9	6,71	38,65	



NF Compressors





8238-23



Secop accepts no responsibility for possible errors in catalogs, brochures, and other printed material. Secop reserves the right to alter its products without notice. This also applies to products already on order provided that such alterations can be made without subsequential changes being necessary to specifications already agreed. All trademarks in this material are the property of the respective companies. Secop and the Secop logotype are trademarks of Secop GmbH. All rights reserved. www.secop.com