

Single Pack NL7.3MF 220-240V 50Hz / 208-230V 60Hz CSIR

Codice Imballo Singolo: **195B4086**

Posizione	Titolo	Codice	Quantità
1	Compressor NL7.3MF	105G6773	1
2	Starting relay	117U6016	1
3	Starting capacitor (80µF 220V, 6.3mm)	117U5015	1
4	Cord relief	103N1010	1
5	Cover	103N2011	1
6	Bolt joint for one compressor M6 ø16mm	118-1917	1

Secop GmbH • Lise-Meitner-Straße 29 • 24941 Flensburg, Germany • Tel: +49 46149410 • www.secop.com

Secop non si assume alcuna responsabilità per eventuali errori presenti in cataloghi, brochure e altro materiale stampato. Secop si riserva il diritto di modificare i propri prodotti senza preavviso. Ciò vale anche per i prodotti già ordinati, a condizione che tali modifiche possano essere apportate senza che siano necessarie modifiche successive alle specifiche già concordate. Tutti i marchi presenti in questo materiale sono di proprietà delle rispettive aziende. Secop e il logo Secop sono marchi di Secop GmbH. Tutti i diritti sono riservati.

Model

Designation	NL7.3MF	220-240V/50Hz 1~ 208-230V/60Hz 1~	Sales code:	105G6773
-------------	----------------	------------------------------------------	-------------	-----------------

Compressor design

Oil type	Polyolester	Refrigerant(s)	R134a, R513A
Oil viscosity	32cST	Displacement	7,27cm ³ / 0,44cu.in
Oil quantity	268cm ³ / 9,1fl.oz	Compressors on pallet	80
Refr. charge - tech. limit	600g / 21,2oz		
Free gas volume comp.	2360cm ³ / 79,8fl.oz		
Weight	10kg / 22lbs		
Motor protection	1# internal		
Winding resistance main	8,3Ω (at 25°C)		
Winding resistance aux	11,8Ω (at 25°C)		
Max. winding temp.	125°C / 257°F		
Max. discharge temp.	130°C / 266°F		



General - Configurations with NL7.3MF

	Conf. 1	Conf. 2	Conf. 3	Conf. 4
Motorconfiguration	CSIR	CSIR	CSIR	CSIR
Power supply (nominal)	220-240V/50Hz	208-230V/60Hz	220-240V/50Hz	208-230V/60Hz
Number of phases	1	1	1	1
Voltage range	187-254V	187-254V	187-254V	187-253V
Approvals	VDE, UL, CCC, EAC	VDE, UL, CCC, EAC	VDE, UL	VDE, UL
Starting torque	HST	HST	HST	HST
Note	- / -			

Applications with NL7.3MF

	Conf. 1	Conf. 2	Conf. 3	Conf. 4
Refrigerant	R134a	R134a	R513A	R513A
Application	MBP	LBP+MBP	MBP	LBP+MBP
System cooling	fan 3m/s	fan 1,5m/s	fan 3m/s	fan 1,5m/s
Hot gas defrost	-/-	-/-	-/-	-/-
Long interval pull down	OK	OK	OK	OK

Electrical data - Configurations with NL7.3MF

	Conf. 1	Conf. 2	Conf. 3	Conf. 4
Starting device type	relay	relay	relay	relay
Run capacitor	-/-	-/-	-/-	-/-
Start capacitor	80μF	80μF	80μF	80μF
LRA (locked rotor amps / 4s)	10,7A	10,8A	10,7A	10,8A
RLA (rated load amps / 1s)	2,1A	1,8A	2,1A	1,8A
Cut in current	10,7A	10,8A	10,7A	10,8A

Model

Designation **NL7.3MF** 220-240V/50Hz 1~ 208-230V/60Hz 1~ Sales code: **105G6773**

Compressor dimensions

Housing	A Height	197mm / 7,76in
	B Height	191mm / 7,52in
	C Length shell	205mm / 8,07in
	D Length w. cover	254mm / 10in
	E Width	166mm / 6,54in

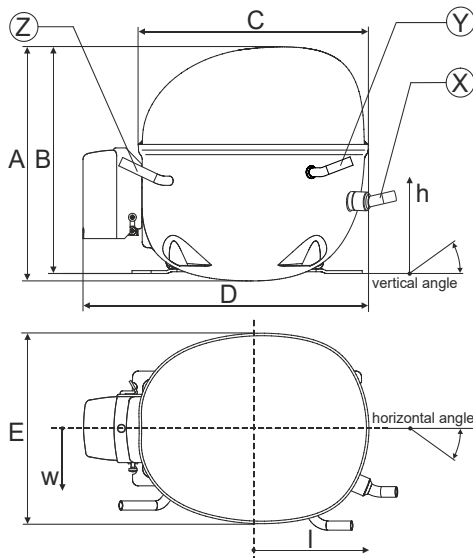

Connectors		Suction	Discharge	Process
		X	Y	Z
Diameter	[mm]	øi 9,61-9,79	øi 6,41-6,59	øi 6,41-6,59
(i:inside, o:outside)	[in]	øi 0,38-0,39	øi 0,25-0,26	øi 0,25-0,26
Material		copper	copper	copper
Horizontal angle	±2°	0°	0°	0°
Vertical angle	±2°	15°	35°	155°
Position l/h/w	[mm]	126/76/78	133/103/54	-107/94/72
	[in]	4,9/3/3,1	5,2/4/2,1	-4,2/3,7/2,8
Straight tube l.	[mm]	12	12	12
	[in]	0,5	0,5	0,5

Compressor fixation

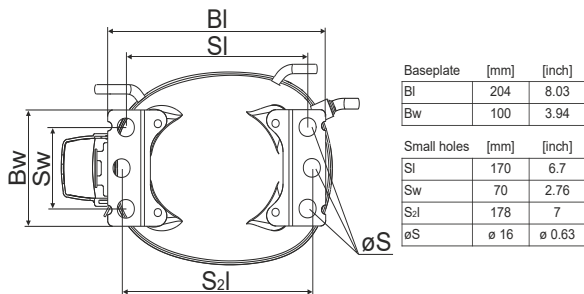

Bolt joint

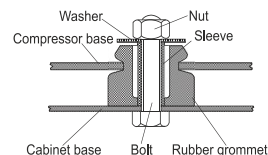

Snap-on

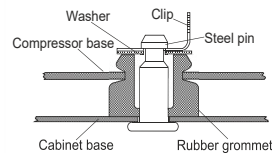

Mounting accessories

	one comp.	multi pack
Bolt joint M6 ø16mm	118-1917	118-1918
Bolt joint ø1/4" ø16mm	118-1946	
Bolt joint ø1/4" ø19mm	118-1949	
Snap-on ø7,3 ø16mm	118-1947	118-1919

Application notes

LRA value on compressor label and datasheet may differ due to different test conditions for UL approval.

Model

Designation	NL7.3MF	220-240V/50Hz	Conf. 1	Sales code:	105G6773
-------------	----------------	----------------------	---------	-------------	-----------------

Configuration

Motorconfiguration	CSIR
Power supply (nominal)	220-240V/50Hz 1~
Refrigerant	R134a
Application	MBP
Voltage range	187-254V
Starting torque	HST
Approvals	VDE
	UL
	CCC
	EAC

Electrical accessories / wiring diagram

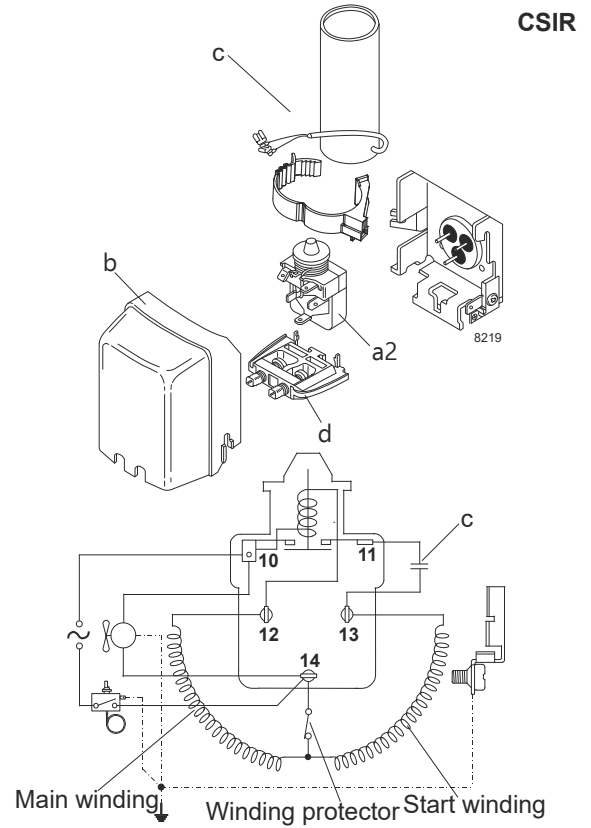

Ambient/ machine room temperatures minimum /maximum

Ambient temperature range: 10 - 43°C / 50 - 110°F

Machine room temperature range: 10 - 48°C / 50 - 119°F

Compressor cooling: fan 1,5m/s

Operation Limits

Operation pressure range

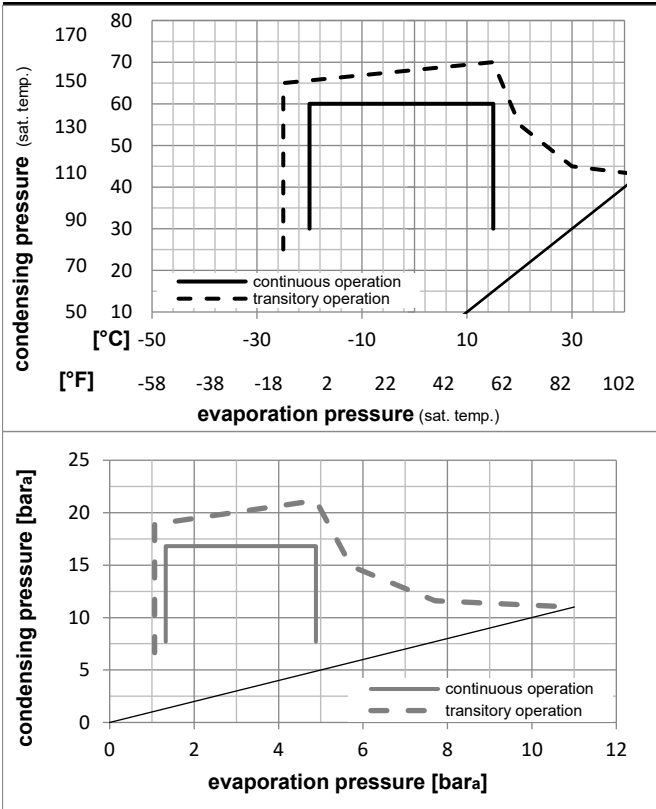

Components

a2	relay	117U6016
c	start capacitor (80µF)	117U5015
b	plastic cover	103N2011
d	cord relief	103N1010

Model

Designation **NL7.3MF** **220-240V/50Hz** Conf. 1 Sales code: **105G6773**

Optimization + standard conditions

R134a, 220V/50Hz, CSIR, fan 1,5m/s, VDE, UL, CCC, EAC

		Evaporating pressure (saturation temperature)				Cooling capacity			COP	EER	Power consumption				
		Condensing pressure (saturation temperature)				Return gas temp.					Current consumption				
		Liquid temp.				Cooling capacity					Ref. mass flow				
		pe	pc	RGT	Tliq	[W]	[Btu/h]	[kcal/h]	[W/W]	[Btu/Wh]	[kcal/Wh]	P1	I	m	
[°C]	[°F]	[°C]	[°F]	[°C]	[°C]							[W]	[A]	[kg/h]	
-7	20	54	130	35	46	395,0	1349	340,0	1,64	5,59	1,41	241,4	1,71	8,62	ASHRAE MBP
-10	14	55	131	32	55	304,1	1039	261,7	1,34	4,58	1,15	226,8	1,67	7,35	cecomaf MBP
-10	14	45	113	20	45	347,1	1185	298,7	1,62	5,52	1,39	214,8	1,63	8,12	EN12900 MBP
-7	20	49	120	18	49	377,8	1290	325,1	1,62	5,53	1,39	233,4	1,69	9,33	ARI540 MBP
-10	14	45	113	32	45	360,1	1230	309,9	1,68	5,72	1,44	214,8	1,63	7,88	opt
-25	-13	45	113	32	45	160,7	549	138,3	1,03	3,50	0,88	156,6	1,54	3,48	opt

Performance tables

R134a, 220V/50Hz, CSIR, fan 1,5m/s, VDE, UL, CCC, EAC

	pe		Cooling capacity			COP	EER		P1	I	m
	[°C]	[°F]	[W]	[Btu/h]	[kcal/h]	[W/W]	[Btu/Wh]	[kcal/Wh]	[W]	[A]	[kg/h]
[°C / °F]	-20	-4	215,3	735	185,3	1,22	4,18	1,05	176,0	1,56	4,68
cond. pressure	-15	5	281,3	961	242,0	1,44	4,92	1,24	195,3	1,59	6,13
pc= 45/113	-10	14	360,1	1230	309,9	1,68	5,72	1,44	214,8	1,63	7,88
return gas temp.	-5	23	453,4	1549	390,2	1,93	6,60	1,66	234,8	1,69	9,97
RGT= 32/90	0	32	562,9	1923	484,5	2,20	7,52	1,90	255,7	1,76	12,45
liquid temp	5	41	690,2	2357	594,0	2,49	8,49	2,14	277,7	1,84	15,37
Tliq= 45/113	15	59	1004,7	3431	864,7	3,08	10,51	2,65	326,6	2,04	22,76
[°C / °F]	-20	-4	179,3	612	154,3	0,99	3,37	0,85	181,5	1,57	4,30
cond. pressure	-15	5	236,2	807	203,3	1,16	3,95	1,00	204,1	1,61	5,69
pc= 55/131	-10	14	304,1	1039	261,7	1,34	4,58	1,15	226,8	1,67	7,35
return gas temp	-5	23	384,8	1314	331,1	1,54	5,26	1,32	249,9	1,74	9,35
RGT= 32/90	0	32	479,7	1638	412,8	1,75	5,99	1,51	273,7	1,82	11,73
liquid temp	5	41	590,5	2017	508,2	1,98	6,76	1,70	298,5	1,91	14,55
Tliq= 55/131	15	59	866,6	2960	745,8	2,46	8,40	2,12	352,5	2,14	21,77

Model

Designation	NL7.3MF	208-230V/60Hz	Conf. 2	Sales code:	105G6773
-------------	----------------	----------------------	----------------	-------------	-----------------

Configuration

Motorconfiguration	CSIR
Power supply (nominal)	208-230V/60Hz 1~
Refrigerant	R134a
Application	LBP+MBP
Voltage range	187-254V
Starting torque	HST
Approvals	VDE
	UL
	CCC
	EAC

Electrical accessories / wiring diagram

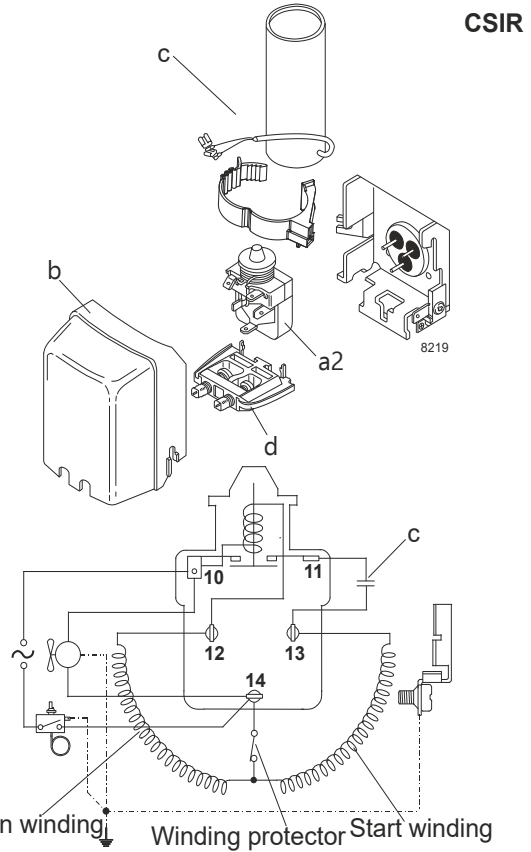

Ambient/ machine room temperatures minimum /maximum

Ambient temperature range:	10 - 43°C / 50 - 110°F
Machine room temperature range:	10 - 48°C / 50 - 119°F
Compressor cooling:	fan 1,5m/s

Operation Limits

Operation pressure range

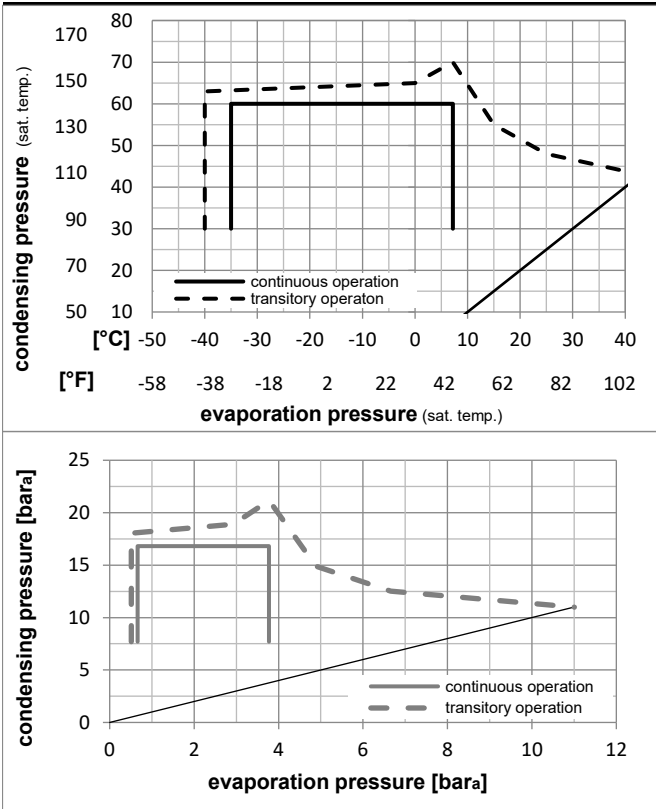

Components

a2	relay	117U6016
c	start capacitor (80µF)	117U5015
b	plastic cover	103N2011
d	cord relief	103N1010

Model

Designation **NL7.3MF** **208-230V/60Hz** Conf. 2 Sales code: **105G6773**

Optimization + standard conditions

R134a, 220V/60Hz, CSIR, fan 1,5m/s, VDE, UL, CCC, EAC

		Evaporating pressure (saturation temperature)				Condensing pressure (saturation temperature)					Power consumption				
		Return gas temp.		Liquid temp.		Cooling capacity			COP	EER	P1		Current consumption		Ref. mass flow
		pe	pc	RGT	Tliq	[W]	[Btu/h]	[kcal/h]	[W/W]	[Btu/Wh]	[kcal/Wh]	[W]	[A]	[kg/h]	
[°C]	-7	54	35	46	471,3	1610	405,6	1,59	5,42	1,37	297,0	1,75	10,28	ASHRAE MBP	
[°F]	20	130	95	115											
[°C]	-10	55	32	55	363,0	1240	312,4	1,32	4,51	1,14	275,0	1,66	8,78	cecomaf MBP	
[°F]	14	131	90	131											
[°C]	-10	45	20	45	417,0	1424	358,9	1,60	5,47	1,38	260,6	1,61	9,76	EN12900 MBP	
[°F]	14	113	68	113											
[°C]	-7	49	18	49	453,6	1549	390,3	1,58	5,41	1,36	286,3	1,71	11,20	ARI540 MBP	
[°F]	20	120	65	120											
[°C]	-10	45	32	45	432,6	1478	372,3	1,66	5,67	1,43	260,6	1,61	9,47	opt	
[°F]	14	113	90	113											
[°C]	-25	45	32	45	200,2	684	172,3	1,13	3,88	0,98	176,4	1,32	4,34	opt	
[°F]	-13	113	90	113											

Performance tables

R134a, 220V/60Hz, CSIR, fan 1,5m/s, VDE, UL, CCC, EAC

	pe		Cooling capacity			COP	EER		P1	I	m
	[°C]	[°F]	[W]	[Btu/h]	[kcal/h]	[W/W]	[Btu/Wh]	[kcal/Wh]	[W]	[A]	[kg/h]
[°C / °F]	-35	-31	105,3	360	90,7	0,86	2,93	0,74	122,9	1,16	2,27
cond. pressure	-25	-13	200,2	684	172,3	1,13	3,88	0,98	176,4	1,32	4,34
pc= 45/113	-15	5	340,7	1164	293,2	1,47	5,01	1,26	232,2	1,50	7,43
return gas temp.	-10	14	432,6	1478	372,3	1,66	5,67	1,43	260,6	1,61	9,47
RGT= 32/90	-5	23	541,4	1849	465,9	1,87	6,40	1,61	289,1	1,72	11,91
liquid temp	0	32	668,9	2284	575,6	2,11	7,19	1,81	317,6	1,85	14,79
Tliq= 45/113	7,2	45	888,9	3036	765,0	2,48	8,47	2,14	358,3	2,04	19,86
[°C / °F]	-35	-31	73,1	250	62,9	0,67	2,27	0,57	109,8	1,11	1,74
cond. pressure	-25	-13	159,4	544	137,2	0,92	3,13	0,79	173,8	1,30	3,81
pc= 55/131	-15	5	282,8	966	243,4	1,17	4,01	1,01	240,8	1,53	6,81
return gas temp	-10	14	363,0	1240	312,4	1,32	4,51	1,14	275,0	1,66	8,78
RGT= 32/90	-5	23	458,0	1564	394,2	1,48	5,05	1,27	309,6	1,80	11,13
liquid temp	0	32	569,6	1945	490,2	1,65	5,65	1,42	344,3	1,94	13,93
Tliq= 55/131	7,2	45	763,1	2606	656,7	1,93	6,61	1,67	394,4	2,16	18,87

Model

Designation	NL7.3MF	220-240V/50Hz	Conf. 3	Sales code:	105G6773
-------------	----------------	----------------------	---------	-------------	-----------------

Configuration

Motorconfiguration	CSIR
Power supply (nominal)	220-240V/50Hz 1~
Refrigerant	R513A
Application	MBP
Voltage range	187-254V
Starting torque	HST
Approvals	VDE UL

Electrical accessories / wiring diagram

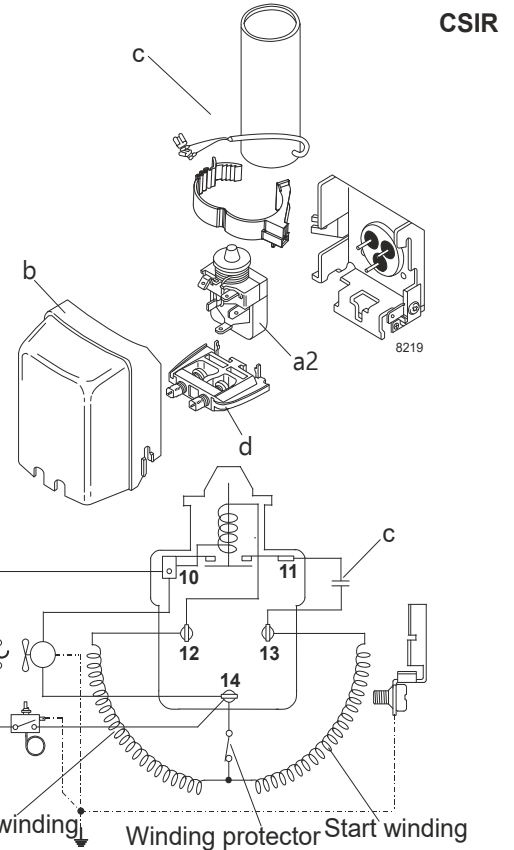

Ambient/ machine room temperatures minimum /maximum

Ambient temperature range:	10 - 43°C / 50 - 110°F
Machine room temperature range:	10 - 48°C / 50 - 119°F
Compressor cooling:	fan 1,5m/s

Operation Limits

Operation pressure range

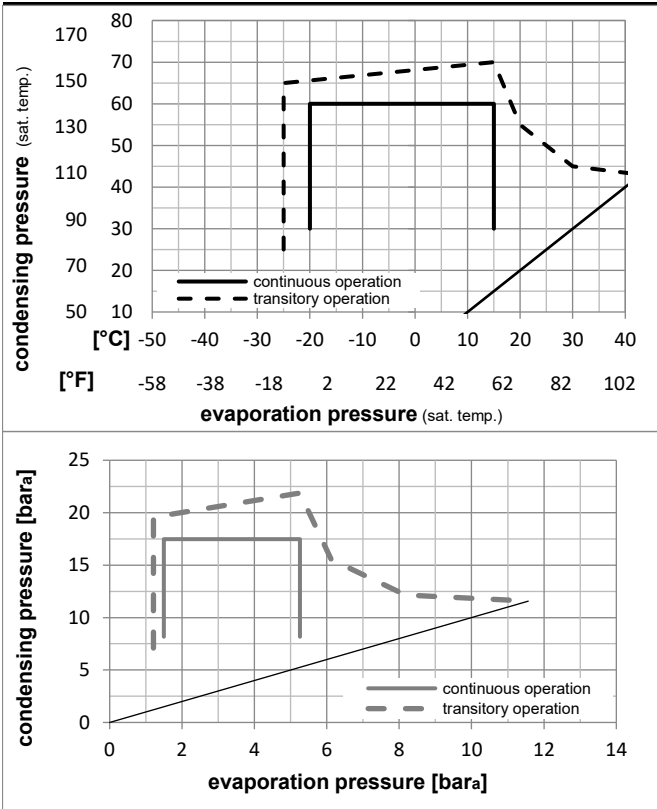

Components

a2	relay	117U6016
c	start capacitor (80µF)	117U5015
b	plastic cover	103N2011
d	cord relief	103N1010

Model

Designation **NL7.3MF** **220-240V/50Hz** Conf. **3** Sales code: **105G6773**

Optimization + standard conditions

R513A, 220V/50Hz, CSIR, fan 1,5m/s, VDE, UL

		Evaporating pressure (saturation temperature)				Cooling capacity			COP	EER	P1	I	Ref. mass flow		
		pe	pc	RGT	Tliq	[W]	[Btu/h]	[kcal/h]	[W/W]	[Btu/Wh]	[kcal/Wh]	[W]	[A]	[kg/h]	
[°C]	[°F]														
-7	20	54	130	35	95	415,5	1419	357,6	1,63	5,57	1,40	254,9	1,76	10,18	ASHRAE MBP
-10	14	55	131	32	90	316,3	1080	272,2	1,32	4,49	1,13	240,5	1,72	8,75	cecomaf MBP
-10	14	45	113	20	68	363,4	1241	312,8	1,60	5,47	1,38	227,0	1,68	9,63	EN12900 MBP
-7	20	49	120	18	65	390,5	1334	336,1	1,59	5,42	1,37	246,1	1,73	11,00	ARI540 MBP
-10	14	45	113	32	90	380,0	1298	327,1	1,67	5,72	1,44	227,0	1,68	9,34	opt
-25	-13	45	113	32	90	175,8	601	151,3	1,05	3,57	0,90	168,1	1,52	4,29	opt

Performance tables

R513A, 220V/50Hz, CSIR, fan 1,5m/s, VDE, UL

	pe		Cooling capacity			COP	EER		P1	I	m
	[°C]	[°F]	[W]	[Btu/h]	[kcal/h]	[W/W]	[Btu/Wh]	[kcal/Wh]	[W]	[A]	[kg/h]
[°C / °F]	-20	-4	232,3	793	199,9	1,24	4,22	1,06	187,9	1,58	5,67
cond. pressure	-15	5	299,8	1024	258,0	1,45	4,94	1,24	207,4	1,63	7,35
pc= 45/113	-10	14	380,0	1298	327,1	1,67	5,72	1,44	227,0	1,68	9,34
return gas temp.	-5	23	474,4	1620	408,3	1,92	6,56	1,65	247,0	1,74	11,71
RGT= 32/90	0	32	584,4	1996	503,0	2,18	7,46	1,88	267,7	1,79	14,50
liquid temp	5	41	711,7	2431	612,5	2,46	8,39	2,11	289,6	1,85	17,75
Tliq= 45/113	15	59	1023,9	3497	881,2	3,03	10,33	2,60	338,4	1,98	25,91
[°C / °F]	-20	-4	191,3	653	164,6	0,98	3,35	0,84	194,9	1,59	5,25
cond. pressure	-15	5	248,5	849	213,9	1,14	3,90	0,98	217,8	1,66	6,84
pc= 55/131	-10	14	316,3	1080	272,2	1,32	4,49	1,13	240,5	1,72	8,75
return gas temp	-5	23	396,3	1354	341,1	1,50	5,14	1,29	263,5	1,78	11,01
RGT= 32/90	0	32	490,0	1674	421,7	1,71	5,83	1,47	287,1	1,84	13,68
liquid temp	5	41	598,9	2045	515,4	1,92	6,56	1,65	311,7	1,91	16,83
Tliq= 55/131	15	59	868,3	2966	747,3	2,38	8,12	2,05	365,3	2,05	24,80

Model

Designation	NL7.3MF	208-230V/60Hz	Conf. 4	Sales code:	105G6773
-------------	----------------	----------------------	---------	-------------	-----------------

Configuration

Motorconfiguration	CSIR
Power supply (nominal)	208-230V/60Hz 1~
Refrigerant	R513A
Application	LBP+MBP
Voltage range	187-253V
Starting torque	HST
Approvals	VDE UL

Electrical accessories / wiring diagram

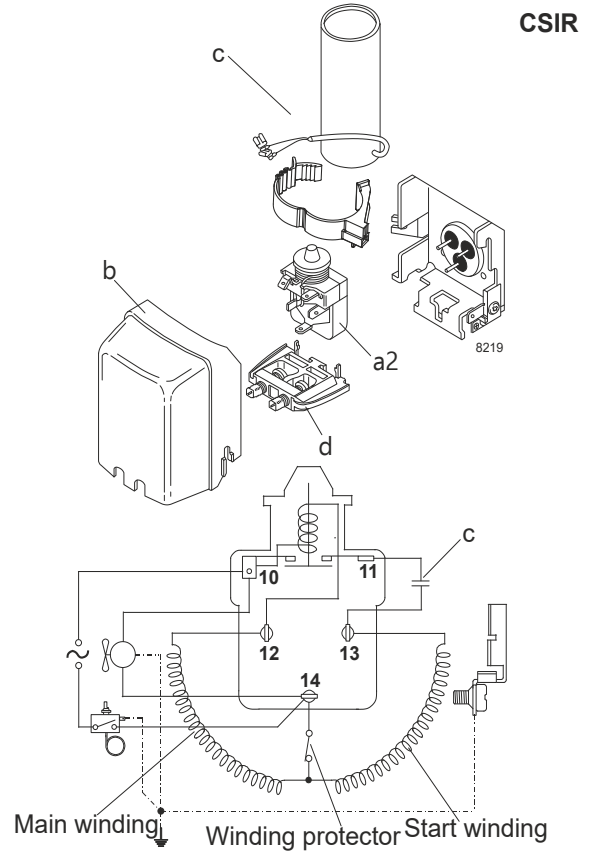

Ambient/ machine room temperatures minimum /maximum

Ambient temperature range:	10 - 43°C / 50 - 110°F
Machine room temperature range:	10 - 48°C / 50 - 119°F
Compressor cooling:	fan 1,5m/s

Operation Limits

Operation pressure range

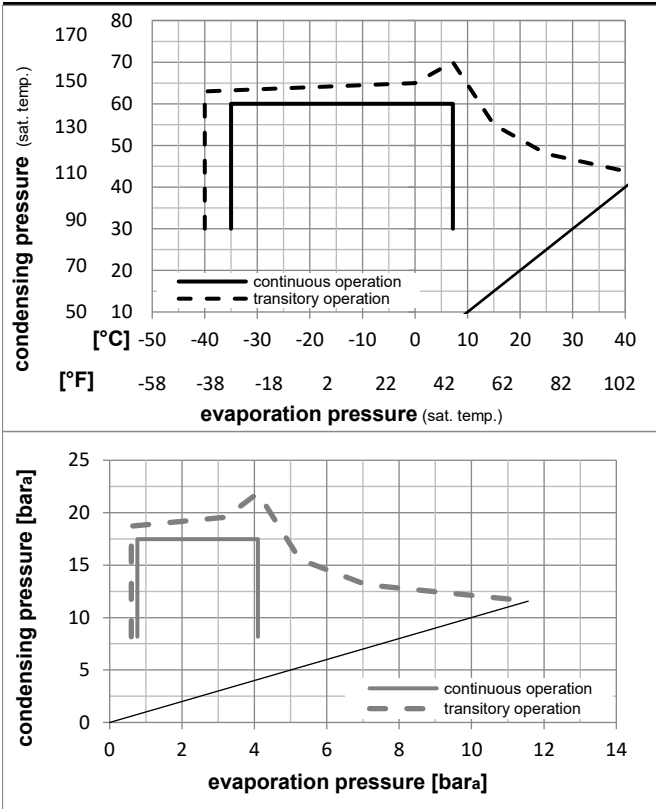

Components

a2	relay	117U6016
c	start capacitor (80µF)	117U5015
b	plastic cover	103N2011
d	cord relief	103N1010

Model

Designation **NL7.3MF** **208-230V/60Hz** Conf. 4 Sales code: **105G6773**

Optimization + standard conditions

R513A, 220V/60Hz, CSIR, fan 1,5m/s, VDE, UL

		Evaporating pressure (saturation temperature)				Cooling capacity			COP	EER	Power consumption				
		Condensing pressure (saturation temperature)		Return gas temp.	Liquid temp.	[W]	[Btu/h]	[kcal/h]	[W/W]	[Btu/Wh]	[kcal/Wh]	P1	I	Ref. mass flow	
[°C]	[°F]	pe	pc	RGT	Tliq							[W]	[A]	[kg/h]	
[°C]	-7	54	35	46		495,7	1693	426,6	1,57	5,36	1,35	315,6	1,84	12,14	ASHRAE MBP
[°F]	20	130	95	115											
[°C]	-10	55	32	55		377,5	1289	324,9	1,29	4,39	1,11	293,6	1,75	10,44	cecomaf MBP
[°F]	14	131	90	131											
[°C]	-10	45	20	45		436,6	1491	375,7	1,57	5,38	1,35	277,3	1,69	11,57	EN12900 MBP
[°F]	14	113	68	113											
[°C]	-7	49	18	49		468,7	1601	403,4	1,54	5,27	1,33	303,8	1,79	13,21	ARI540 MBP
[°F]	20	120	65	120											
[°C]	-10	45	32	45		456,5	1559	392,9	1,65	5,62	1,42	277,3	1,69	11,22	opt
[°F]	14	113	90	113											
[°C]	-25	45	32	45		219,1	748	188,6	1,14	3,90	0,98	191,7	1,35	5,34	opt
[°F]	-13	113	90	113											

Performance tables

R513A, 220V/60Hz, CSIR, fan 1,5m/s, VDE, UL

	pe		Cooling capacity			COP	EER		P1	I	m
	[°C]	[°F]	[W]	[Btu/h]	[kcal/h]	[W/W]	[Btu/Wh]	[kcal/Wh]	[W]	[A]	[kg/h]
[°C / °F]	-35	-31	120,6	412	103,8	0,88	3,02	0,76	136,3	1,14	2,93
cond. pressure	-25	-13	219,1	748	188,6	1,14	3,90	0,98	191,7	1,35	5,34
pc= 45/113	-15	5	363,2	1240	312,6	1,46	4,99	1,26	248,6	1,58	8,90
return gas temp.	-10	14	456,5	1559	392,9	1,65	5,62	1,42	277,3	1,69	11,22
RGT= 32/90	-5	23	566,3	1934	487,4	1,85	6,32	1,59	306,0	1,80	13,98
liquid temp	0	32	694,2	2371	597,5	2,08	7,09	1,79	334,4	1,91	17,22
Tliq= 45/113	7,2	45	913,8	3121	786,4	2,44	8,33	2,10	374,8	2,07	22,86
[°C / °F]	-35	-31	84,9	290	73,1	0,69	2,34	0,59	123,7	1,09	2,32
cond. pressure	-25	-13	173,1	591	149,0	0,91	3,11	0,78	190,2	1,35	4,74
pc= 55/131	-15	5	297,5	1016	256,0	1,15	3,93	0,99	258,8	1,61	8,19
return gas temp	-10	14	377,5	1289	324,9	1,29	4,39	1,11	293,6	1,75	10,44
RGT= 32/90	-5	23	471,7	1611	406,0	1,44	4,90	1,24	328,5	1,89	13,10
liquid temp	0	32	581,7	1987	500,6	1,60	5,47	1,38	363,3	2,02	16,25
Tliq= 55/131	7,2	45	771,4	2634	663,9	1,87	6,38	1,61	413,1	2,22	21,75



8238-20

NL Compressors

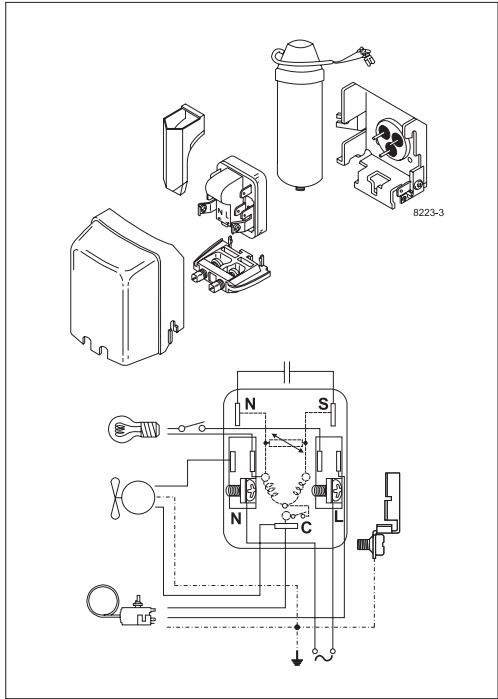
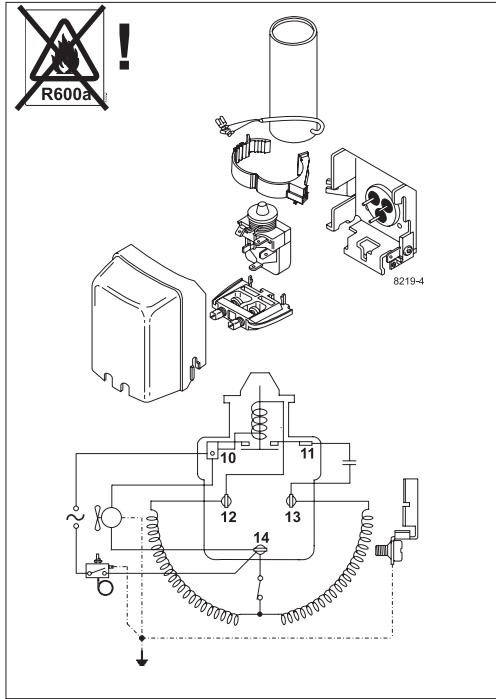
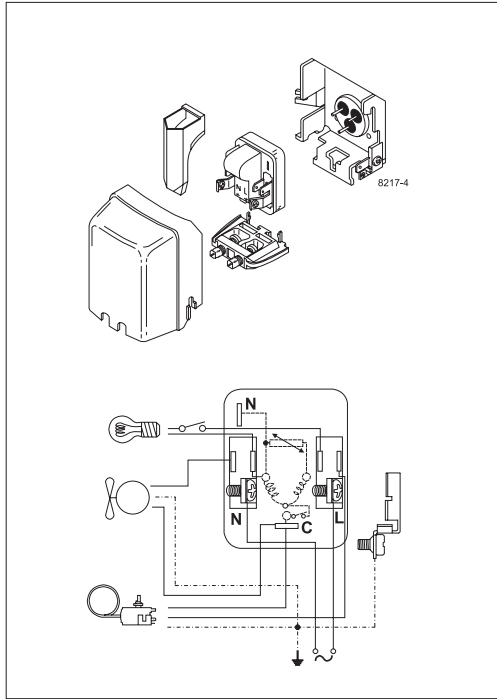



Service/Repair – R600a, R290



8545

Brazing on Suction Connectors (Direct Intake)

representative image



**! max. 150°C/302°F !
at socket**
brazing solder: phosphor (LP7) or silver

Refer to Product Bulletin:
**Brazing on Suction Connectors
(Compressors with Direct Suction Intake)**

Secop accepts no responsibility for possible errors in catalogs, brochures, and other printed material. Secop reserves the right to alter its products without notice. This also applies to products already on order provided that such alterations can be made without subsequential changes being necessary to specifications already agreed. All trademarks in this material are the property of the respective companies. Secop and the Secop logotype are trademarks of Secop GmbH. All rights reserved. www.secop.com