

Single Pack SC18F 220-240V 50Hz CSIR

Codice Imballo Singolo: **195B4098**

Posizione	Titolo	Codice	Quantità
1	Compressor SC18F	104G8800	1
2	Starting relay	117U6005	1
3	Starting capacitor (80 μ F 220V, 6.3mm)	117U5017	1
4	Cord relief	103N1004	1
5	Cover	103N2009	1
6	Bolt joint for one compressor M6 \varnothing 16mm	118-1917	1

Secop GmbH • Lise-Meitner-Straße 29 • 24941 Flensburg, Germany • Tel: +49 46149410 • www.secop.com

Secop non si assume alcuna responsabilità per eventuali errori presenti in cataloghi, brochure e altro materiale stampato. Secop si riserva il diritto di modificare i propri prodotti senza preavviso. Ciò vale anche per i prodotti già ordinati, a condizione che tali modifiche possano essere apportate senza che siano necessarie modifiche successive alle specifiche già concordate. Tutti i marchi presenti in questo materiale sono di proprietà delle rispettive aziende. Secop e il logo Secop sono marchi di Secop GmbH. Tutti i diritti sono riservati.

Model

Designation	SC18F	220-240V/50Hz 1~	Sales code:	104G8800
-------------	--------------	------------------	-------------	-----------------

Compressor design

Oil type	Polyolester	Refrigerant(s)	R134a
Oil viscosity	22cST	Displacement	17,69cm ³ / 1,08cu.in
Oil quantity	550cm ³ / 18,6fl.oz	Compressors on pallet	80
Refr. charge - tech. limit	1300g / 45,9oz		
Free gas volume comp.	1410cm ³ / 47,7fl.oz		
Weight	13,1kg / 28,9lbs		
Motor protection	1# internal		
Winding resistance main	5,13Ω (at 25°C)		
Winding resistance aux	13,51Ω (at 25°C)		
Max. winding temp.	125°C / 257°F		
Max. discharge temp.	135°C / 275°F		



General - Configurations with SC18F

	Conf. 1
Motorconfiguration	CSIR
Power supply (nominal)	220-240V/50Hz
Number of phases	1
Voltage range	198-254V
Approvals	VDE, EAC
Starting torque	HST
Note	- / -

Applications with SC18F

	Conf. 1
Refrigerant	R134a
Application	LBP+MBP
System cooling	fan 1,5m/s
Hot gas defrost	OK
Long interval pull down	OK

Electrical data - Configurations with SC18F

	Conf. 1
Starting device type	relay
Run capacitor	-/-
Start capacitor	80μF
LRA (locked rotor amps / 4s)	
RLA (rated load amps / 1s)	-/-A
Cut in current	

Model

Designation

SC18F

220-240V/50Hz 1~

Sales code:

104G8800

Compressor dimensions

Housing	A Height	209mm / 8,23in
	B Height	203mm / 7,99in
	C Length shell	218mm / 8,58in
	D Length w. cover	255mm / 10,04in
	E Width	151mm / 5,94in

Connectors	Suction X	Discharge Y	Process Z
Diameter [mm]	ø 8,11-8,29	ø 6,11-6,29	ø 6,11-6,29
(i:inside, o:outside) [in]	ø 0,32-0,33	ø 0,24-0,25	ø 0,24-0,25
Material	copper	copper	copper
Horizontal angle ±2°	37°	37°	143°
Vertical angle ±2°	30°	0°	150°
Position l/h/w [mm]	107/183/55	115/100/63	-107/183/55
[in]	4,2/7,2/2,2	4,5/3,9/2,5	-4,2/7,2/2,2
Straight tube l. [mm]	12	12	12
[in]	0,5	0,5	0,5



Compressor fixation



Bolt joint



Snap-on

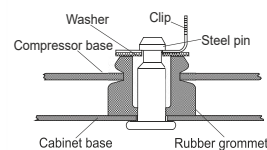

Mounting accessories

Mounting accessories	one comp.	multi pack
Bolt joint M6 ø16mm	118-1917	118-1918
Bolt joint ø1/4" ø16mm	118-1946	
Bolt joint ø1/4" ø19mm	118-1949	
Snap-on ø7,3 ø16mm	118-1947	118-1919

Application notes

Provision for PE Grounding is located at the PE Stamp on the compressor

Model

Designation	SC18F	220-240V/50Hz	Conf. 1	Sales code:	104G8800
-------------	--------------	----------------------	----------------	-------------	-----------------

Configuration

Motorconfiguration	CSIR
Power supply (nominal)	220-240V/50Hz 1~
Refrigerant	R134a
Application	LBP+MBP
Voltage range	198-254V
Starting torque	HST
Approvals	VDE EAC

Electrical accessories / wiring diagram

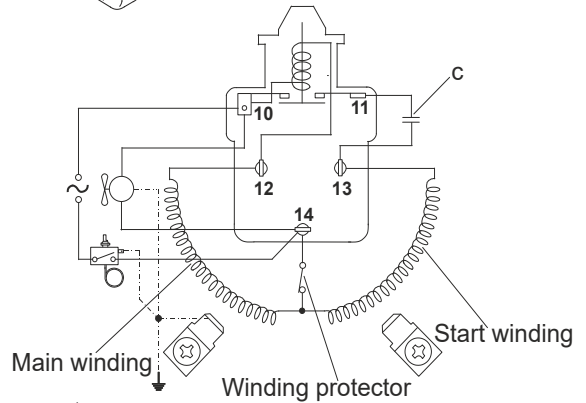
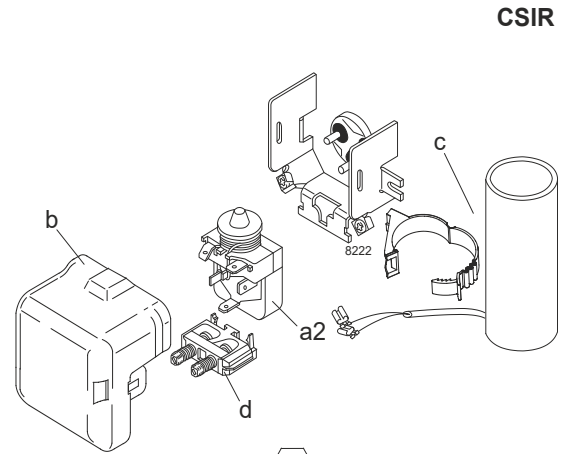

Ambient/ machine room temperatures minimum /maximum

Ambient temperature range:	10 - 38°C / 50 - 101°F
Machine room temperature range:	10 - 43°C / 50 - 110°F
Compressor cooling:	fan 1,5m/s

Operation Limits

Can be used as a HBP compressor with 240V 50Hz mains (216-254V).

Operation pressure range

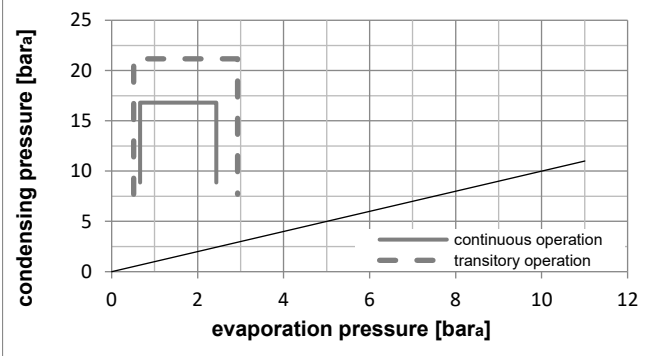
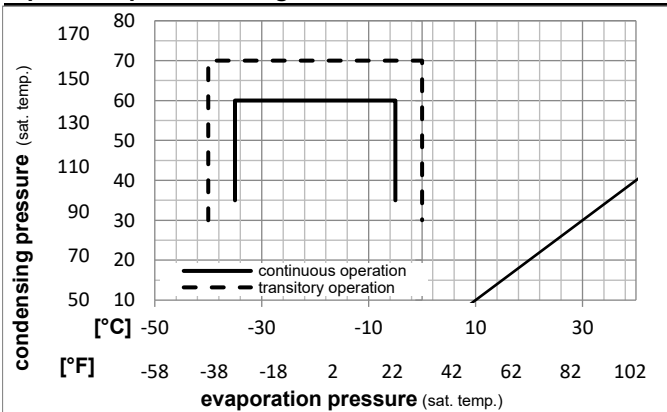

Components

a2	relay	117U6005
c	start capacitor (80μF)	117U5017
d	cord relief	103N1004
b	plastic cover	103N2009

Model

Designation **SC18F** **220-240V/50Hz** Conf. 1 Sales code: **104G8800**

Optimization + standard conditions

R134a, 220V/50Hz, CSIR, fan 1,5m/s, VDE, EAC

		Evaporating pressure (saturation temperature)				Condensing pressure (saturation temperature)			Return gas temp.		Liquid temp.		Cooling capacity			COP	EER	Power consumption		
		pe	pc	RGT	Tliq	[W]	[Btu/h]	[kcal/h]	[W/W]	[Btu/Wh]	[kcal/Wh]	P1	I	Current consumption		Ref. mass flow				
[°C]	[°F]	[°C]	[°F]	[°C]	[°F]							[W]	[A]	[kg/h]	ASHRAE LBP					
-23	-10	54	130	32	90	388,0	1325	333,9	1,17	3,99	1,01	332,2	2,35	7,53	ASHRAE LBP					
-25	-13	55	131	32	90	280,2	957	241,1	0,90	3,06	0,77	312,9	2,29	6,70	cecomaf LBP					
-35	-31	40	104	20	68	187,5	640	161,4	0,84	2,86	0,72	223,8	2,11	4,11	EN12900 LBP					
-23	-10	49	120	4,4	40	323,7	1106	278,6	0,97	3,32	0,84	332,7	2,35	8,55	ARI540 LBP					
-23	-10	41	105	32	90	452,1	1544	389,1	1,39	4,75	1,20	325,2	2,31	8,78	AHAM LBP					
-35	-31	45	113	32	90	168,1	574	144,7	0,76	2,60	0,66	220,8	2,10	3,63	opt					

Performance tables

R134a, 220V/50Hz, CSIR, fan 1,5m/s, VDE, EAC

	pe		Cooling capacity			COP	EER	P1	I	m	
	[°C]	[°F]	[W]	[Btu/h]	[kcal/h]	[W/W]	[Btu/Wh]	[kcal/Wh]	[W]	[A]	[kg/h]
[°C / °F]	-35	-31	168,1	574	144,7	0,76	2,60	0,66	220,8	2,10	3,63
cond. pressure	-30	-22	246,6	842	212,2	0,93	3,17	0,80	265,7	2,18	5,33
pc= 45/113	-25	-13	346,8	1184	298,4	1,11	3,78	0,95	313,3	2,29	7,51
return gas temp.	-23	-10	385,8	1317	332,0	1,17	3,99	1,01	330,0	2,33	8,36
RGT= 32/90	-20	-4	468,6	1600	403,3	1,29	4,40	1,11	363,4	2,43	10,18
liquid temp	-15	5	612,1	2090	526,7	1,47	5,02	1,27	416,0	2,59	13,34
Tliq= 45/113	-5	23	963,5	3291	829,2	1,83	6,23	1,57	527,9	2,95	21,19
[°C / °F]	-35	-31	128,9	440	110,9	0,63	2,14	0,54	206,1	2,04	3,07
cond. pressure	-30	-22	193,7	662	166,7	0,75	2,56	0,65	258,1	2,15	4,62
pc= 55/131	-25	-13	280,2	957	241,1	0,90	3,06	0,77	312,9	2,29	6,70
return gas temp	-23	-10	314,5	1074	270,7	0,95	3,23	0,82	332,1	2,35	7,53
RGT= 32/90	-20	-4	388,3	1326	334,1	1,05	3,58	0,90	370,2	2,46	9,31
liquid temp	-15	5	517,9	1769	445,7	1,20	4,11	1,04	430,0	2,65	12,47
Tliq= 55/131	-5	23	841,6	2874	724,3	1,51	5,17	1,30	556,3	3,05	20,46

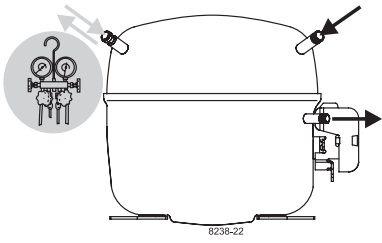

SC Compressors

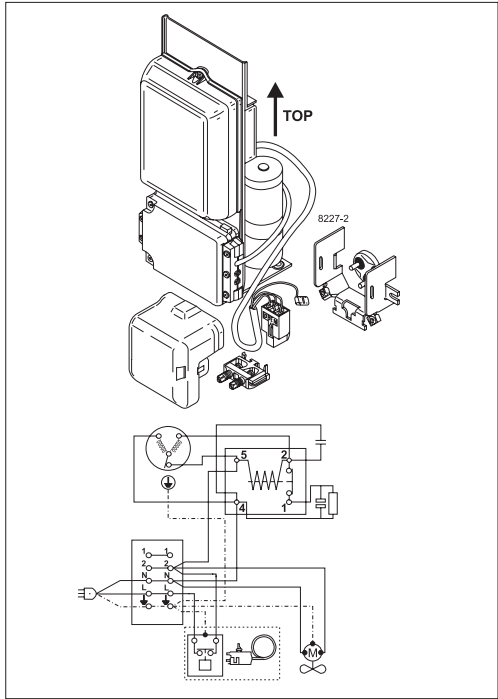
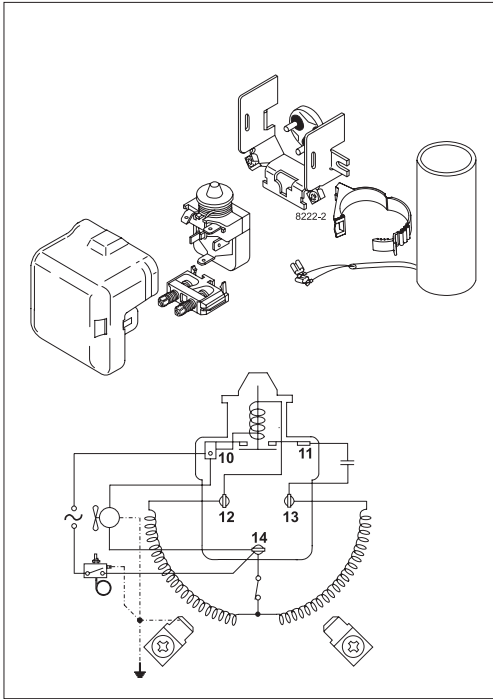
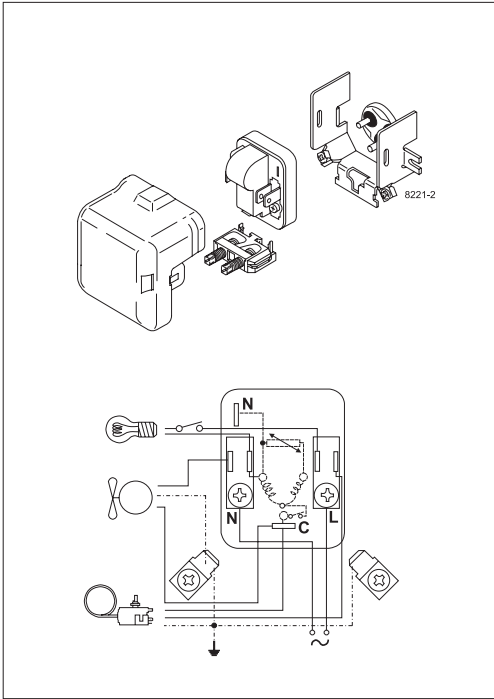



SC Compressors

Service/Repair – R290

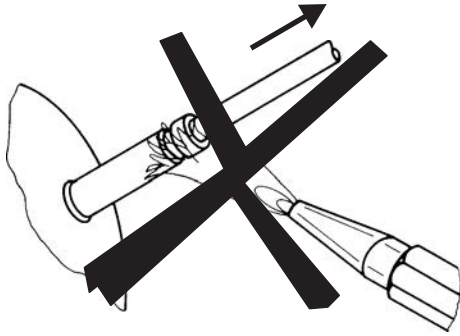

8545



Secop accepts no responsibility for possible errors in catalogs, brochures, and other printed material. Secop reserves the right to alter its products without notice. This also applies to products already on order provided that such alterations can be made without subsequent changes being necessary to specifications already agreed. All trademarks in this material are the property of the respective companies. Secop and the Secop logotype are trademarks of Secop GmbH. All rights reserved. www.secop.com