

Single Pack NL11F 220-240V 50Hz CSIR

Codice Imballo Singolo: **195B4113**

Posizione	Titolo	Codice	Quantità
1	Compressor NL11F	105G6900	1
2	Starting relay	117U6002	1
3	Starting capacitor (80 μ F 220V, 6.3mm)	117U5015	1
4	Cord relief	103N1010	1
5	Cover	103N2010	1
6	Bolt joint for one compressor M6 \varnothing 16mm	118-1917	1

Secop GmbH • Lise-Meitner-Straße 29 • 24941 Flensburg, Germany • Tel: +49 46149410 • www.secop.com

Secop non si assume alcuna responsabilità per eventuali errori presenti in cataloghi, brochure e altro materiale stampato. Secop si riserva il diritto di modificare i propri prodotti senza preavviso. Ciò vale anche per i prodotti già ordinati, a condizione che tali modifiche possano essere apportate senza che siano necessarie modifiche successive alle specifiche già concordate. Tutti i marchi presenti in questo materiale sono di proprietà delle rispettive aziende. Secop e il logo Secop sono marchi di Secop GmbH. Tutti i diritti sono riservati.

NL11F Standard Compressor R134a 220-240V 50Hz

General

Code number	105G6900
Approvals	EN 60335-2-34 with Annex AA
Compressors on pallet	80

Application

Application	LBP		
Frequency	Hz	50	60
Evaporating temperature	°C	-35 to -10	-
Voltage range	V	198 - 254	-
Max. condensing temperature continuous (short)	°C	60 (70)	-
Max. winding temperature continuous (short)	°C	125 (135)	-

Cooling requirements

Frequency	Hz	50			60		
Application		LBP	MBP	HBP	LBP	MBP	HBP
32°C		F ₁	-	-	-	-	-
38°C		F ₁	-	-	-	-	-
43°C		-	-	-	-	-	-
Remarks on application:							

Motor

Motor type	RSIR/CSIR		
LRA (rated after 4 sec. UL984), HST LST	A	10.4	9.2
Cut in Current, HST LST	A	10.4	13.6
Resistance, main start winding (25°C)	Ω	8.2	14.7

Design

Displacement	cm ³	11.15
Oil quantity (type)	cm ³	300
Maximum refrigerant charge	g	400
Free gas volume in compressor	cm ³	2360
Weight without electrical equipment	kg	10.7

Dimensions

Height	mm	A	203
		B	197
		B1	-
		B2	-
Suction connector	location/I.D. mm angle	C	8.2 15°
		material comment	Copper Rubber plug
Process connector	location/I.D. mm angle	D	6.2 25°
		material comment	Copper Rubber plug
Discharge connector	location/I.D. mm angle	E	6.2 35°
		material comment	Copper Rubber plug
Oil cooler connector	location/I.D. mm angle	F	-
		material comment	-
Connector tolerance	I.D. mm		±0.09
Remarks:			

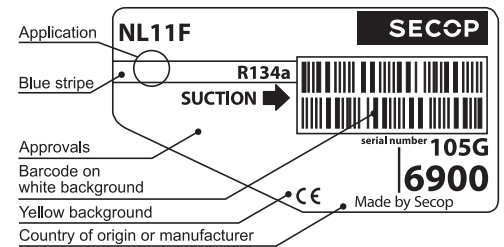

- S = Static cooling normally sufficient
- O = Oil cooling
- F₁ = Fan cooling 1.5 m/s (compressor compartment temperature equal to ambient temperature)
- F₂ = Fan cooling 3.0 m/s necessary
- SG = Suction gas cooling normally sufficient
- = not applicable in this area

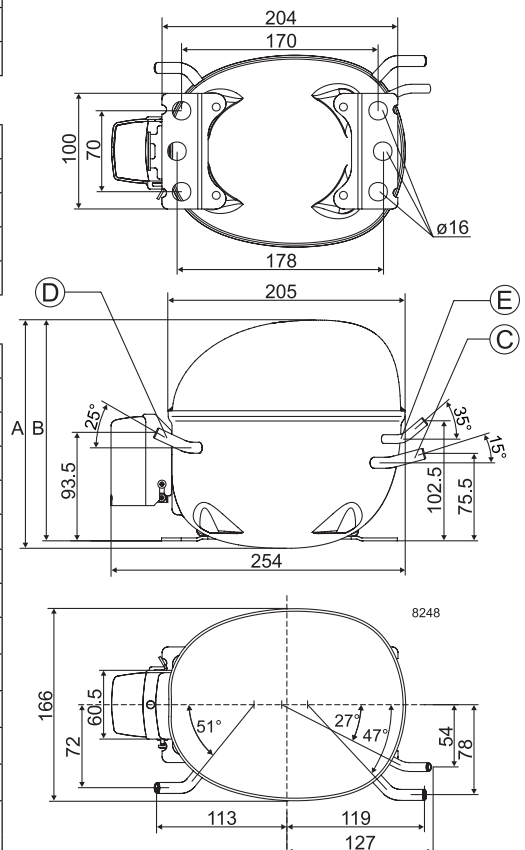

EN 12900 Household (CECOMAF) 220V, 50Hz, fan cooling F1

Evap. temp in °C	-45	-40	-35	-30	-25	-23.3	-20	-15	-10	-6.7	-5	0	5	7.2	10	15	20
Capacity in W			102	146	200	222	268	351	453								
Power cons. in W			137	175	212	225	250	289	331								
Current cons. in A			1.41	1.46	1.54	1.58	1.66	1.82	2.01								
COP in W/W			0.75	0.83	0.94	0.99	1.07	1.22	1.37								

ASHRAE LBP 220V, 50Hz, fan cooling F1

Evap. temp in °C	-45	-40	-35	-30	-25	-23.3	-20	-15	-10	-6.7	-5	0	5	7.2	10	15	20
Capacity in W			126	180	247	274	332	435	560								
Power cons. in W			138	175	212	224	249	287	329								
Current cons. in A			1.41	1.46	1.54	1.57	1.66	1.81	2.00								
COP in W/W			0.92	1.03	1.17	1.22	1.33	1.51	1.70								



Accessories for	NL11F	Figure	Code number
PTC starting device	6.3 mm spade connectors	a1	103N0011
	4.8 mm spade connectors		103N0018
Starting relay	6.3 mm spade connectors	a2	117U6002
Start capacitor 80 µF	6.3 mm spade connectors	c	117U5015
Cover		b	103N2010
Cord relief		d	103N1010
Protection screen for PTC		g	103N0476

Test conditions	EN 12900/ CECOMAF	ASHRAE
Condensing temperature	54.4°C	55°C
Ambient temperature	32°C	32°C
Suction gas temperature	32°C	32°C
Liquid temperature	no subcooling	32°C

Mounting accessories		Code number
Bolt joint for one comp.	Ø: 16 mm	118-1917
Bolt joint in quantities	Ø: 16 mm	118-1918
Snap-on in quantities	Ø: 16 mm	118-1919

Secop accepts no responsibility for possible errors in catalogs, brochures, and other printed material. Secop reserves the right to alter its products without notice. This also applies to products already on order provided that such alterations can be made without subsequential changes being necessary to specifications already agreed. All trademarks in this material are the property of the respective companies. Secop and the Secop logotype are trademarks of Secop GmbH. All rights reserved. www.secop.com



NL Compressors





Service/Repair – R600a, R290



8545

Brazing on Suction Connectors (Direct Intake)

representative image



**! max. 150°C/302°F !
at socket**
brazing solder: phosphor (LP7) or silver

Refer to Product Bulletin:
**Brazing on Suction Connectors
(Compressors with Direct Suction Intake)**

Secop accepts no responsibility for possible errors in catalogs, brochures, and other printed material. Secop reserves the right to alter its products without notice. This also applies to products already on order provided that such alterations can be made without subsequential changes being necessary to specifications already agreed. All trademarks in this material are the property of the respective companies. Secop and the Secop logotype are trademarks of Secop GmbH. All rights reserved. www.secop.com