

Single Pack SC12CLX.2 115V 60Hz CSIR

Codice Imballo Singolo: **195B4117**

Posizione	Titolo	Codice	Quantità
1	Compressor SC12CLX.2	104L1696	1
2	Starting relay	117U6020	1
3	Starting capacitor (240 μ F 125V, 6.3mm)	117U5023	1
4	Cord relief	103N1004	1
5	Cover	103N2008	1
6	Bolt joint for one compressor M6 \varnothing 16mm	118-1917	1

Secop GmbH • Lise-Meitner-Straße 29 • 24941 Flensburg, Germany • Tel: +49 46149410 • www.secop.com

Secop non si assume alcuna responsabilità per eventuali errori presenti in cataloghi, brochure e altro materiale stampato. Secop si riserva il diritto di modificare i propri prodotti senza preavviso. Ciò vale anche per i prodotti già ordinati, a condizione che tali modifiche possano essere apportate senza che siano necessarie modifiche successive alle specifiche già concordate. Tutti i marchi presenti in questo materiale sono di proprietà delle rispettive aziende. Secop e il logo Secop sono marchi di Secop GmbH. Tutti i diritti sono riservati.

Model

Designation	SC12CLX.2	115V/60Hz 1~	Sales code:	104L1696
-------------	------------------	--------------	-------------	-----------------

Compressor design

Oil type	Polyolester	Refrigerant(s)	R404A, R452A, R507
Oil viscosity	32cSt	Displacement	12,87cm ³ / 0,79cu.in
Oil quantity	500cm ³ / 16,9fl.oz	Compressors on pallet	80
Refr. charge - tech. limit	1300g / 45,9oz		
Free gas volume comp.	1510cm ³ / 51,1fl.oz		
Weight	13,2kg / 29,1lbs		
Motor protection	1# internal		
Winding resistance main	0,98Ω (at 25°C)		
Winding resistance aux	4,18Ω (at 25°C)		
Max. winding temp.	125°C / 257°F		
Max. discharge temp.	130°C / 266°F		



General - Configurations with SC12CLX.2

	Conf. 1	Conf. 2
Motorconfiguration	CSIR	CSIR
Power supply (nominal)	115V/60Hz	115V/60Hz
Number of phases	1	1
Voltage range	103-127V	103-127V
Approvals	UL	UL
Starting torque	HST	HST
Note	- / -	

Applications with SC12CLX.2

	Conf. 1	Conf. 2
Refrigerant	R404A	R452A
Application	LBP	LBP
System cooling	fan 3m/s	fan 3m/s
Hot gas defrost	OK	OK
Long interval pull down	OK	OK

Electrical data - Configurations with SC12CLX.2

	Conf. 1	Conf. 2
Starting device type	relay	relay
Run capacitor	- / -	- / -
Start capacitor	240μF	240μF
LRA (locked rotor amps / 4s)	39,7A	39,7A
RLA (rated load amps / 1s)	7,6A	7,6A
Cut in current	39,7A	39,7A
IP class	21	21

Model

Designation	SC12CLX.2	115V/60Hz 1~	Sales code:	104L1696
-------------	------------------	--------------	-------------	-----------------

Compressor dimensions

Housing	A Height	209mm / 8,23in
	B Height	203mm / 7,99in
	C Length shell	218mm / 8,58in
	D Length w. cover	255mm / 10,04in
	E Width	151mm / 5,94in

Connectors		Suction	Discharge	Process
		X	Y	Z
Diameter	[mm]	øi 8,11-8,29	øi 6,41-6,59	øi 6,41-6,59
(i:inside, o:outside)	[in]	øi 0,32-0,33	øi 0,25-0,26	øi 0,25-0,26
Material		copper	copper	copper
Horizontal angle	±2°	37°	37°	143°
Vertical angle	±2°	30°	0°	150°
Position l/h/w	[mm]	107/183/55	115/100/63	-107/183/55
	[in]	4,2/7,2/2,2	4,5/3,9/2,5	-4,2/7,2/2,2
Straight tube l.	[mm]	12	12	12
	[in]	0,5	0,5	0,5

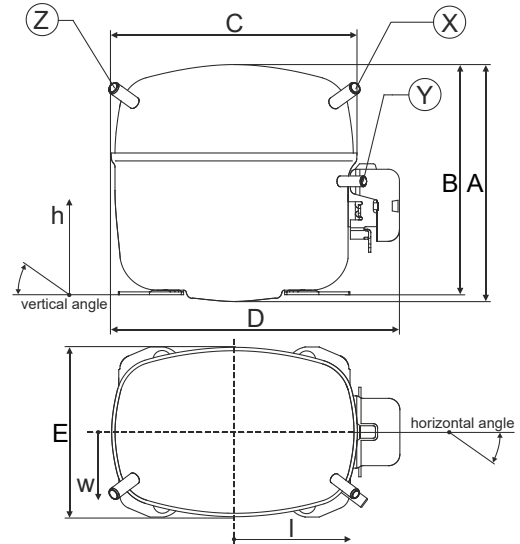

Compressor fixation

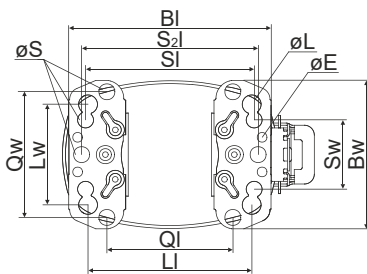

Baseplate	[mm]	[inch]
BI	204	8.03
BW	150	5.9
øE	ø 9.7	ø 0.38
Large holes	[mm]	[inch]
LI	165	6.5
LW	101.6	4
øL	ø 19	ø 0.75
Small holes	[mm]	[inch]
SI	170	6.7
Sw	70	2.76
øS	ø 16	ø 0.63
QI	127	5
Qw	127	5

Bolt joint

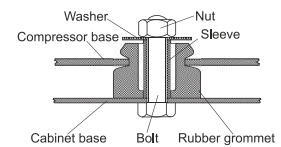

Snap-on

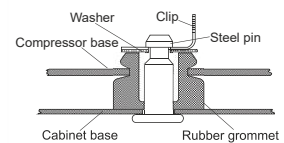

Mounting accessories

	one comp.	multi pack
Bolt joint M6 ø16mm	118-1917	118-1918
Bolt joint ø1/4" ø16mm	118-1946	
Bolt joint ø1/4" ø19mm	118-1949	
Snap-on ø7,3 ø16mm	118-1947	118-1919

Application notes

LRA value on compressor label and datasheet may differ due to different test conditions for UL approval.

Model

Designation **SC12CLX.2 115V/60Hz** Conf. 1 Sales code: **104L1696**

Configuration

Motorconfiguration CSIR
 Power supply (nominal) 115V/60Hz 1~
 Refrigerant R404A
 Application LBP
 Voltage range 103-127V
 Starting torque HST
 Approvals UL

Electrical accessories / wiring diagram

CSIR

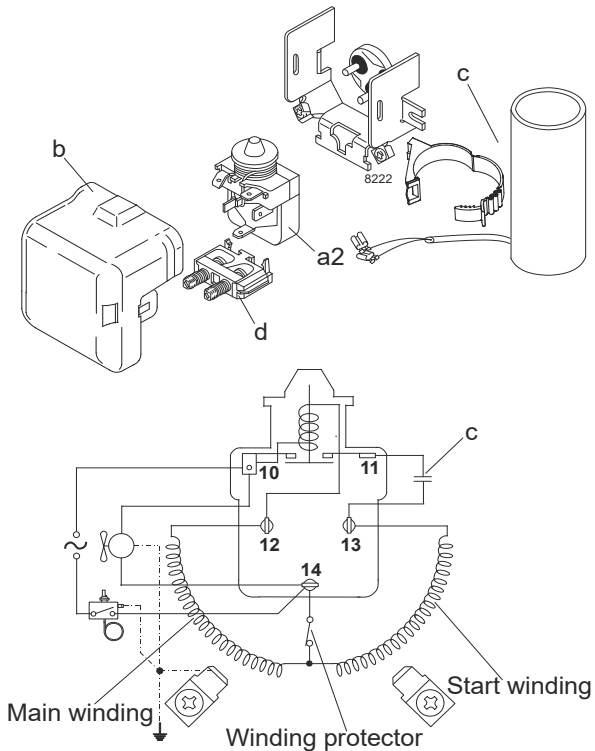

Ambient temperatures / system cooling

Ambient temperature min.: 10°C / 50°F
 Ambient temperature max.: 43°C / 110°F

System cooling (n/a: outside limits)			
T ambient	LBP	MBP	HBP
32°C / 90°F	fan 3m/s	n/a	n/a
38°C / 100°F	fan 3m/s	n/a	n/a
43°C / 110°F	fan 3m/s	n/a	n/a

Operation pressure range

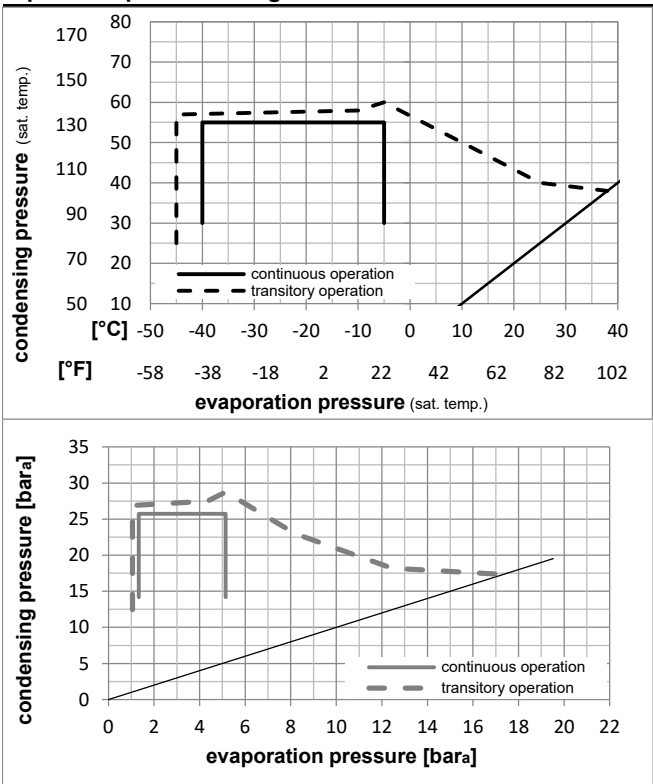

Components

- a2 relay 117U6020
- c start capacitor (240µF) 117U5023
- d cord relief 103N1004
- b plastic cover 103N2008

Alternative components

- a2 relay 117U6020
- c start capacitor (240µF, 15kOhm) 117U5034
- d cord relief 103N1004
- b plastic cover 103N2008

Model

Designation **SC12CLX.2 115V/60Hz** Conf. 1 Sales code: **104L1696**

Optimization + standard conditions

115V/60Hz, CSIR, fan 3m/s, UL

Evaporating pressure (saturation temperature)														
Condensing pressure (saturation temperature)														
Return gas temp.														
Liquid temp.														
Cooling capacity														
COP														
EER														
Power consumption														
Current consumption														
Ref. mass flow														
	pe	pc	RGT	Tliq	[W]	[Btu/h]	[kcal/h]	[W/W]	[Btu/Wh]	[kcal/Wh]	P1	I	m	
[°C]	[°C]	[°C]	[°C]	[°C]	[W]	[Btu/h]	[kcal/h]	[W/W]	[Btu/Wh]	[kcal/Wh]	[W]	[A]	[kg/h]	
[°F]	-23,3	54,4	32,2	32,2	723,4	2471	622,6	1,14	3,89	0,98	634,4	7,20	16,86	ASHRAE LBP
[°F]	-10	130	90	90										
[°C]	-25	55	32	55	485,9	1659	418,1	0,80	2,75	0,69	604,1	7,00	15,18	cecomaf LBP
[°F]	-13	131	89,6	131										
[°C]	-35	40	20	40	371,8	1270	319,9	0,84	2,86	0,72	444,0	6,10	10,10	EN12900 LBP
[°F]	-31	104	68	104										
[°C]	-23,3	48,9	4,44	48,9	537,8	1837	462,8	0,86	2,93	0,74	627,0	7,16	19,04	ARI540 LBP
[°F]	-10	120	40	120										
[°C]	-23,3	40,6	32,2	32,2	812,5	2775	699,2	1,33	4,53	1,14	613,2	7,09	18,93	AHAM LBP
[°F]	-10	105	90	90										
[°C]	-35	45	32	45	334,2	1141	287,6	0,77	2,62	0,66	435,0	6,03	8,93	opt
[°F]	-31	113	89,6	113										

Performance tables

115V/60Hz, CSIR, fan 3m/s, UL

	pe	Cooling capacity			COP	EER	P1	I	m			
		[°C]	[°F]	[W]						[Btu/h]	[kcal/h]	[W/W]
[°C / °F]	-40	-40		214,3	732	184,4	0,62	2,12	0,53	345,6	5,66	5,71
cond. pressure	-34,4	-30		348,4	1190	299,8	0,78	2,68	0,67	444,4	6,08	9,32
pc= 45/113	-28,9	-20		501,7	1713	431,7	0,94	3,21	0,81	534,6	6,57	13,48
return gas temp.	-23,3	-10		678,5	2317	583,9	1,09	3,73	0,94	621,2	7,12	18,33
RGT= 32/90	-20,6	-5		777,0	2654	668,7	1,17	3,99	1,01	664,8	7,43	21,07
liquid temp	-15	5		997,2	3406	858,2	1,32	4,51	1,14	755,7	8,10	27,24
Tliq= 45/113	-5	23		1483,0	5065	1276,3	1,57	5,36	1,35	945,3	9,48	41,23
[°C / °F]	-40	-40		108,5	370	93,3	0,38	1,29	0,33	286,7	5,43	3,34
cond. pressure	-34,4	-30		235,9	806	203,0	0,57	1,94	0,49	415,2	5,95	7,30
pc= 55/131	-28,9	-20		376,8	1287	324,3	0,71	2,43	0,61	529,6	6,54	11,72
return gas temp	-23,3	-10		535,6	1829	461,0	0,84	2,88	0,73	635,1	7,21	16,78
RGT= 32/90	-20,6	-5		623,1	2128	536,3	0,91	3,10	0,78	686,1	7,56	19,59
liquid temp	-15	5		816,9	2790	703,0	1,04	3,54	0,89	787,6	8,34	25,91
Tliq= 55/131	-5	23		1240,8	4238	1067,9	1,26	4,31	1,09	982,6	9,91	40,16

Model

Designation	SC12CLX.2	115V/60Hz	Conf. 2	Sales code:	104L1696
-------------	------------------	------------------	----------------	-------------	-----------------

Configuration

Motorconfiguration	CSIR
Power supply (nominal)	115V/60Hz 1~
Refrigerant	R452A
Application	LBP
Voltage range	103-127V
Starting torque	HST
Approvals	UL

Electrical accessories / wiring diagram

CSIR

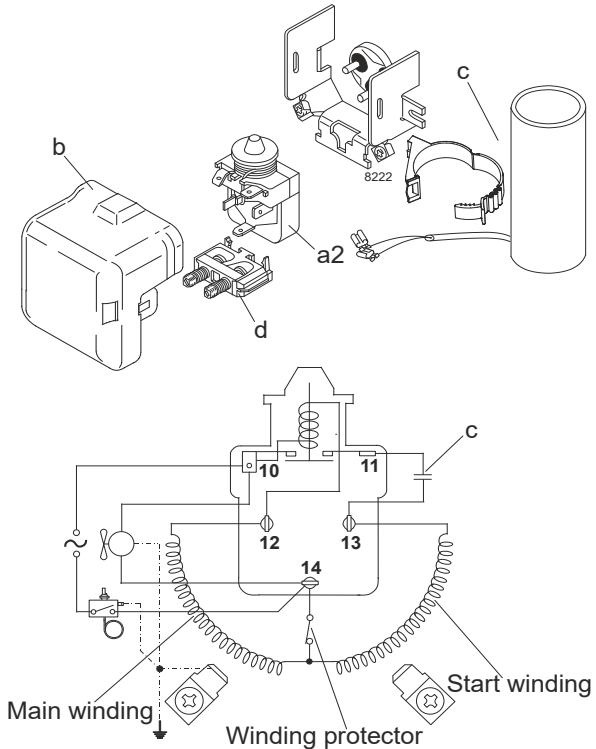

Ambient temperatures / system cooling

Ambient temperature min.:	10°C / 50°F
Ambient temperature max.:	43°C / 110°F

System cooling (n/a: outside limits)			
T ambient	LBP	MBP	HBP
32°C / 90°F	fan 3m/s	n/a	n/a
38°C / 100°F	fan 3m/s	n/a	n/a
43°C / 110°F	fan 3m/s	n/a	n/a

Operation pressure range

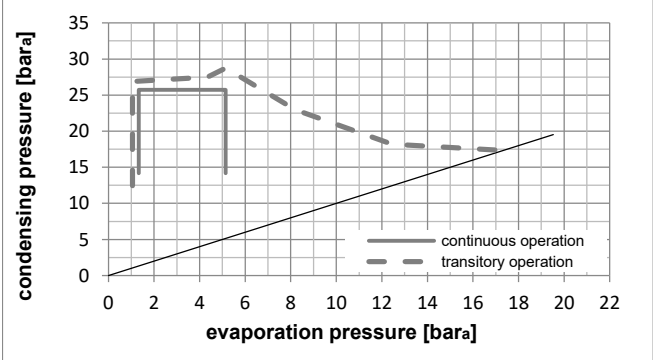
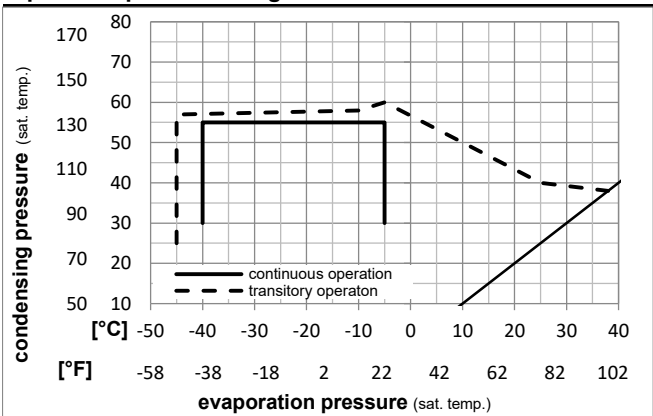

Components

a2	relay	117U6020
c	start capacitor (240µF)	117U5023
d	cord relief	103N1004
b	plastic cover	103N2008

Alternative components

a2	relay	117U6020
c	start capacitor (240µF, 15kOhm)	117U5034
d	cord relief	103N1004
b	plastic cover	103N2008

Model

Designation **SC12CLX.2 115V/60Hz** Conf. 2 Sales code: **104L1696**

Optimization + standard conditions

115V/60Hz, CSIR, fan 3m/s, UL

Evaporating pressure (saturation temperature)														
Condensing pressure (saturation temperature)														
Return gas temp.														
Liquid temp.														
Cooling capacity														
COP														
EER														
Power consumption														
Current consumption														
Ref. mass flow														
	pe	pc	RGT	Tliq	[W]	[Btu/h]	[kcal/h]	[W/W]	[Btu/Wh]	[kcal/Wh]	P1	I	m	
[°C]	[°C]	[°C]	[°C]	[°C]	[W]	[Btu/h]	[kcal/h]	[W/W]	[Btu/Wh]	[kcal/Wh]	[W]	[A]	[kg/h]	
[°C]	-23,3	54,4	32,2	32,2	661,5	2259	569,3	1,13	3,85	0,97	587,2	6,99	15,90	ASHRAE LBP
[°F]	-10	130	90	90										
[°C]	-25	55	32	55	447,9	1530	385,4	0,80	2,74	0,69	557,4	6,79	14,25	cecomaf LBP
[°F]	-13	131	89,6	131										
[°C]	-35	40	20	40	335,2	1145	288,5	0,83	2,82	0,71	405,8	5,76	9,36	EN12900 LBP
[°F]	-31	104	68	104										
[°C]	-23,3	48,9	4,44	48,9	499,6	1706	430,0	0,86	2,93	0,74	581,8	6,95	17,96	ARI540 LBP
[°F]	-10	120	40	120										
[°C]	-23,3	40,6	32,2	32,2	747,8	2554	643,5	1,31	4,48	1,13	570,2	6,87	17,97	AHAM LBP
[°F]	-10	105	90	90										
[°C]	-35	45	32	45	300,2	1025	258,4	0,76	2,59	0,65	396,2	5,69	8,24	opt
[°F]	-31	113	89,6	113										

Performance tables

115V/60Hz, CSIR, fan 3m/s, UL

	pe	Cooling capacity			COP	EER	P1	I	m			
		[°C]	[°F]	[W]						[Btu/h]	[kcal/h]	[W/W]
[°C / °F]	-40	-40		187,8	642	161,7	0,60	2,06	0,52	310,9	5,11	5,14
cond. pressure	-34,4	-30		313,6	1071	269,9	0,77	2,64	0,67	405,2	5,75	8,61
pc= 45/113	-28,9	-20		458,4	1566	394,5	0,93	3,18	0,80	492,4	6,35	12,64
return gas temp.	-23,3	-10		626,9	2141	539,5	1,09	3,71	0,93	577,1	6,92	17,37
RGT= 32/90	-20,6	-5		721,5	2464	620,9	1,16	3,97	1,00	619,9	7,21	20,05
liquid temp	-15	5		934,0	3190	803,8	1,32	4,50	1,13	709,4	7,82	26,13
Tliq= 45/113	-5	23		1408,2	4809	1211,9	1,57	5,37	1,35	896,1	9,09	40,01
[°C / °F]	-40	-40		91,0	311	78,3	0,36	1,23	0,31	252,6	4,71	2,86
cond. pressure	-34,4	-30		210,4	719	181,1	0,56	1,92	0,48	374,8	5,55	6,64
pc= 55/131	-28,9	-20		343,8	1174	295,9	0,71	2,42	0,61	485,0	6,29	10,90
return gas temp	-23,3	-10		495,6	1693	426,6	0,84	2,88	0,73	587,7	6,99	15,80
RGT= 32/90	-20,6	-5		579,9	1981	499,1	0,91	3,11	0,78	637,7	7,33	18,55
liquid temp	-15	5		768,1	2623	661,0	1,04	3,56	0,90	737,9	8,01	24,76
Tliq= 55/131	-5	23		1185,2	4048	1020,0	1,27	4,35	1,10	931,3	9,33	38,90



SC Compressors

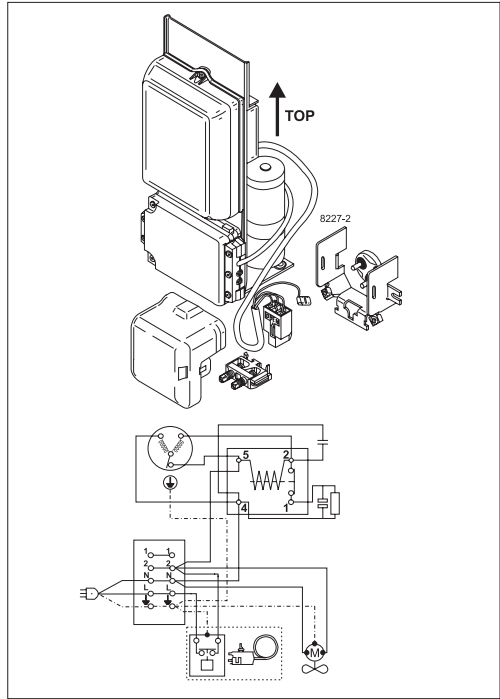



SC Compressors

Service/Repair – R290

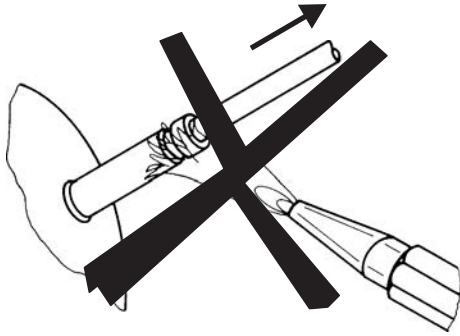

8545



Secop accepts no responsibility for possible errors in catalogs, brochures, and other printed material. Secop reserves the right to alter its products without notice. This also applies to products already on order provided that such alterations can be made without subsequent changes being necessary to specifications already agreed. All trademarks in this material are the property of the respective companies. Secop and the Secop logotype are trademarks of Secop GmbH. All rights reserved. www.secop.com